

TADANO ATF220G-5

■ 寸法図

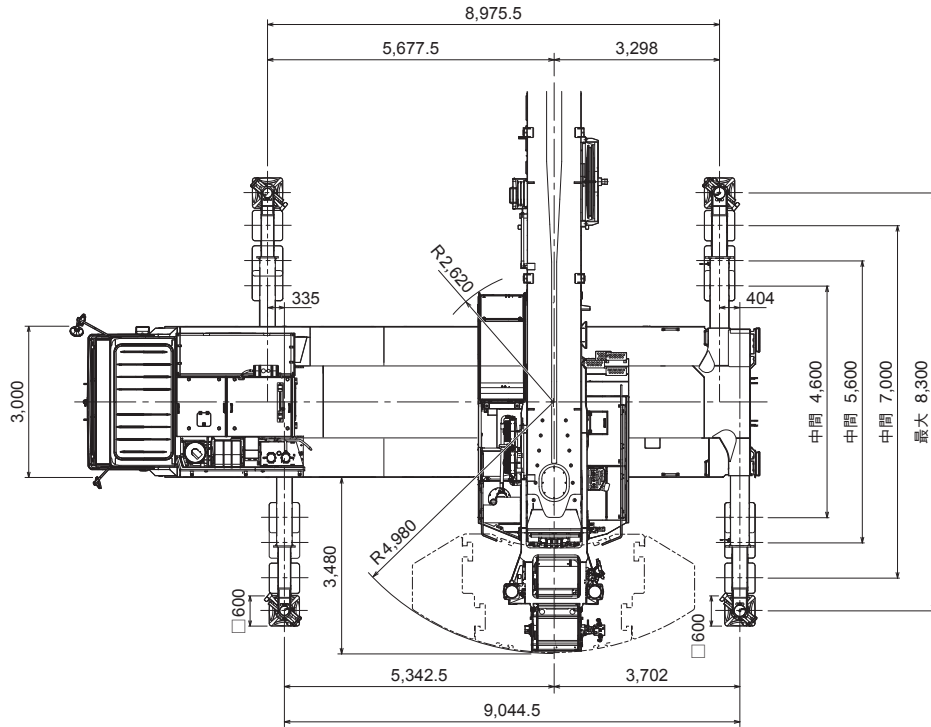

縮尺 1/150 (単位: mm)

ATF220G-5

■ 最小直角通路幅

● 公道走行状態

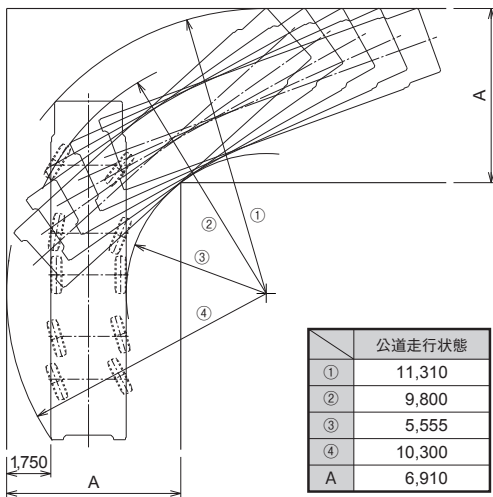

● 構内移動姿勢 (シングルトップ格納)

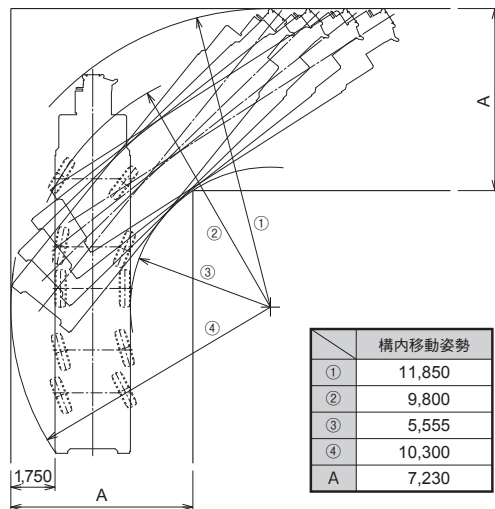

縮尺 1/300 (単位: mm)

TADANO ATF220G-5

■寸法図

●フルオートラフィングジブ (FLJ)

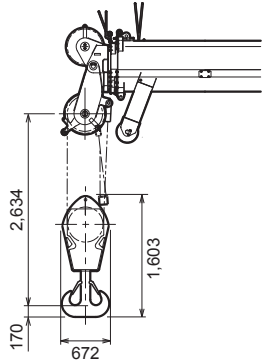

80tフック 1,150kg

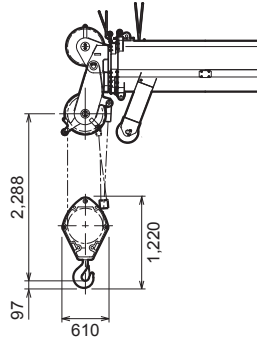

25tフック 450kg

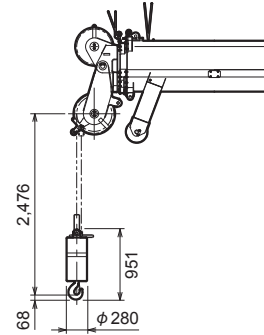

7.8tフック 300kg

縮尺 1/100 (単位: mm)

●イージースカイピンブーム (ESP)

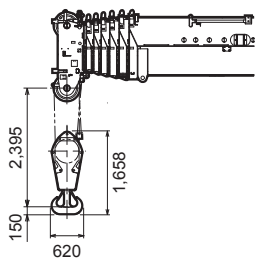

125tフック 1,350kg

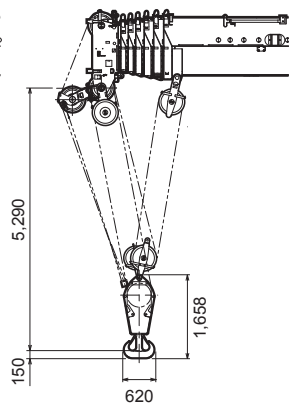

125tアタッチメントシーブ付きフック×2 1,425kg×2

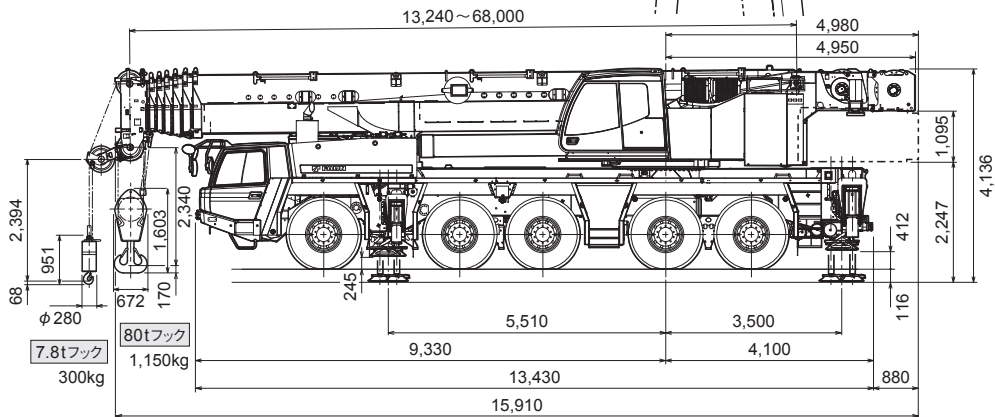
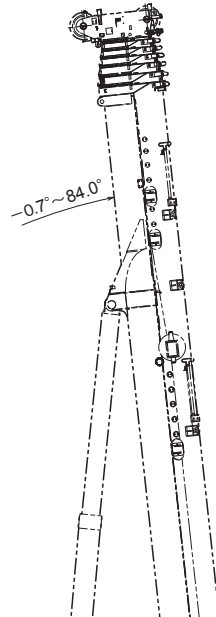

縮尺 1/150 (単位: mm)

ATF220G-5

TADANO ATF220G-5

■公道走行状態

●キャリア + 旋回体 40.75t

(注意)

1. 本機は、公道を走行する場合には、ブームおよび起伏シリンダを外して別送し、旋回体を後方向に向けた状態で走行しなければなりません。
2. 本機は、公道を走行するためには、道路法による特殊車両の通行許可が必要です。基本通行条件 重量：Cが記載された適合証明書を取得していますが、実際の通行経路で申請して許可された条件で走行しなければなりません。
3. 本機は、公道を走行するためには、道路運送車両の保安基準による保安基準緩和の認定が必要です。

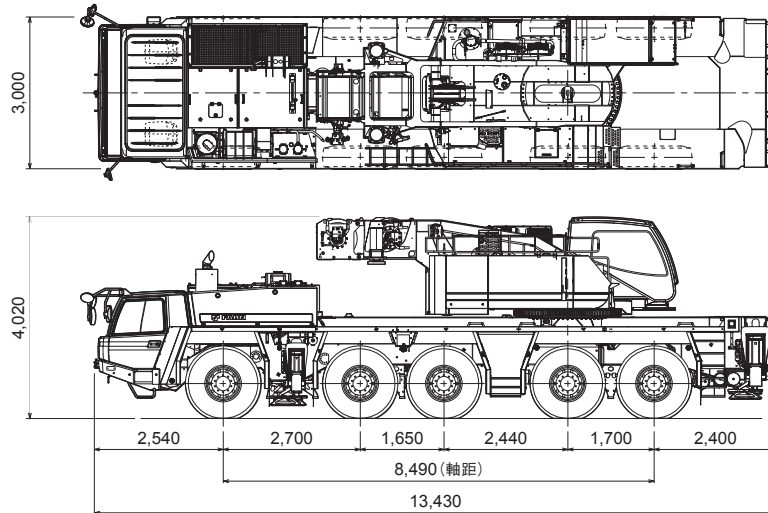

縮尺 1/150 (単位: mm)

■構内移動姿勢

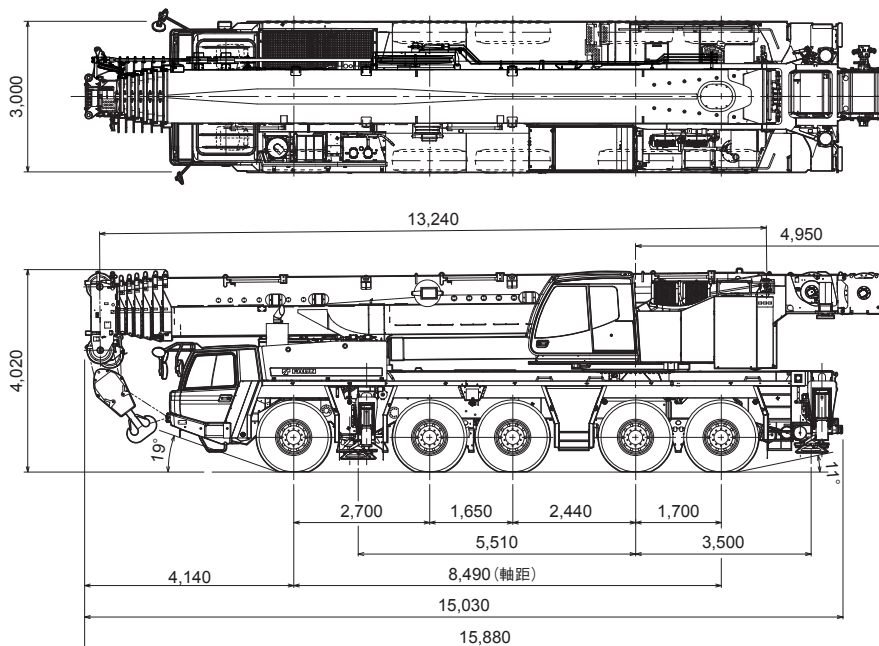

縮尺 1/150 (単位: mm)

TADANO ATF220G-5

■作業範囲図

●ESPブーム

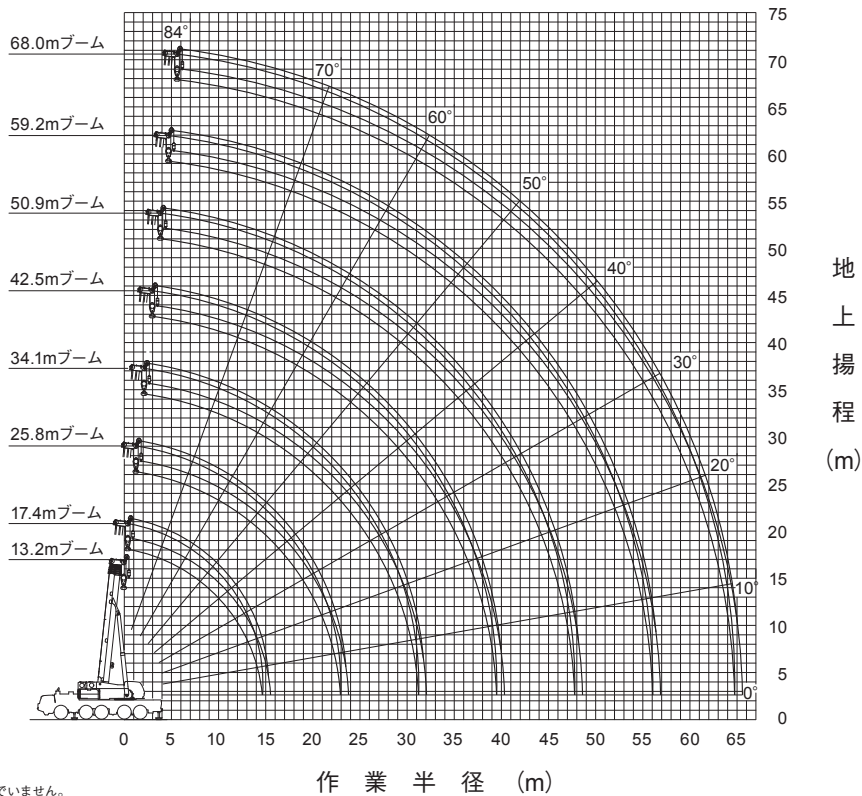
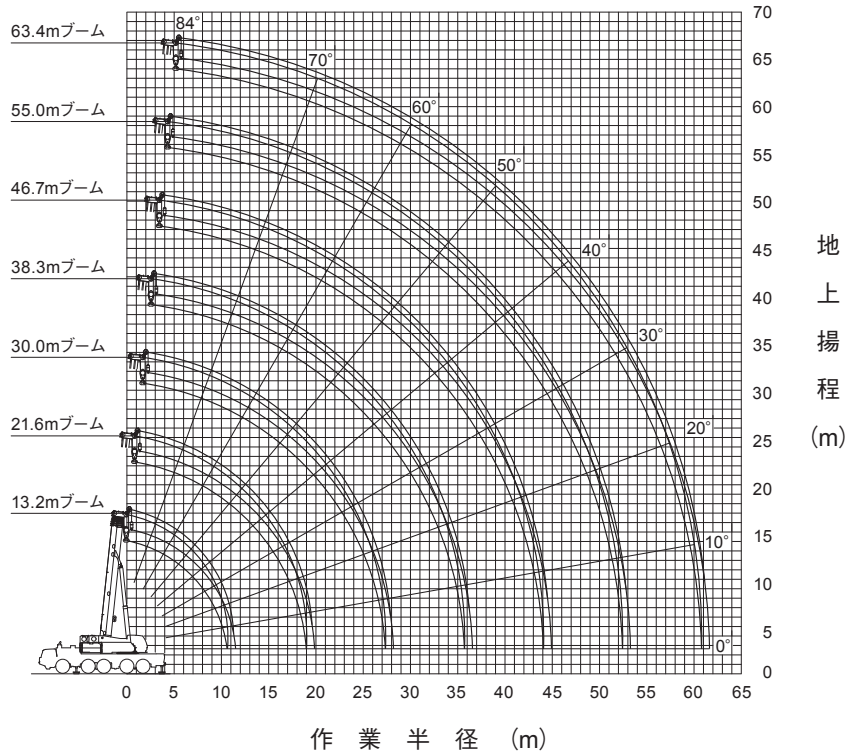

(注) 1. 上図はブームのたわみを含んでいません。
2. A、B、G性能の最大作業半径を図示しています。

縮尺 1/800

ATF220G-5

TADANO ATF220G-5

■性能ブロック図

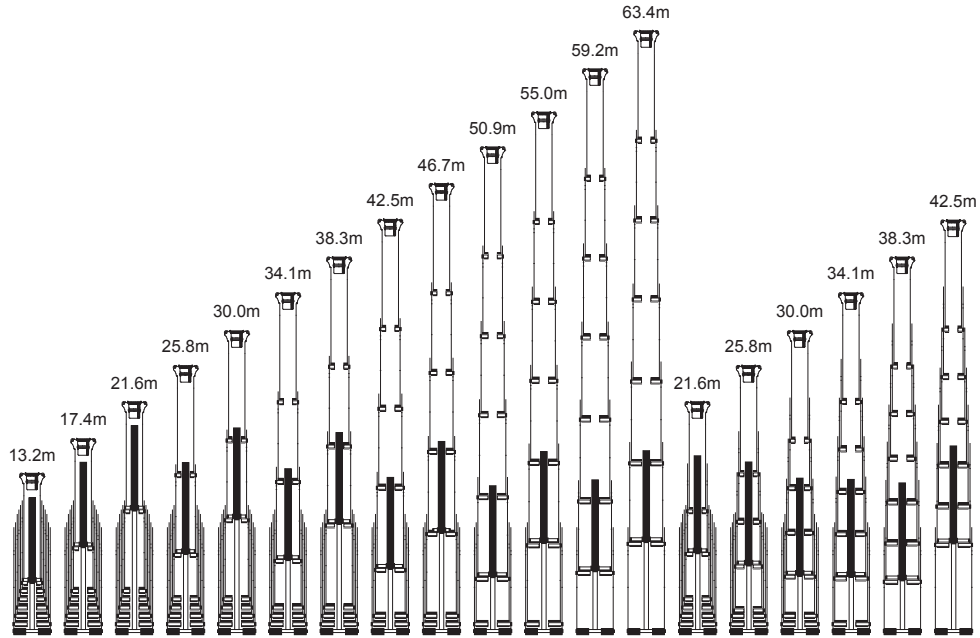

性能番号	1	2	3	4	5	6	7	8	9	10	11	12	13	14	15	16	17	18	19
性能ブロック	1													2					

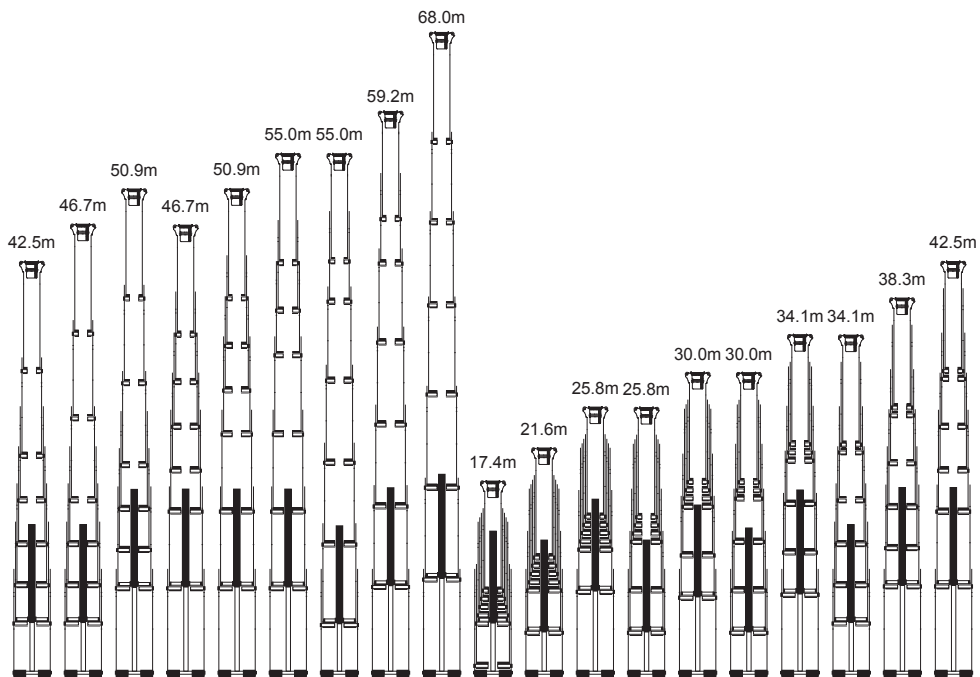

性能番号	20	21	22	23	24	25	26	27	28	29	30	31	32	33	34	35	36	37	38
性能ブロック	3	4	5	6	7	8	9	10	11	12	13	14							

TADANO ATF220G-5

■定格総荷重表

●A性能 7段ESPブーム

(単位: t)

Table with columns for boom length (1-19), boom radius (2.5-64.0), and load capacity (40.4-138.8). Includes sub-tables for boom length, boom radius, and boom weight.

注) カウンタウエイト 71t、アウトリガ張出幅 8.3m ※印はアタッチメント付きの値です。 ※※印は後方限定の値です。

●B性能 7段ESPブーム

(単位: t)

Table with columns for boom length (1-19), boom radius (2.5-64.0), and load capacity (40.4-138.8). Includes sub-tables for boom length, boom radius, and boom weight.

注) カウンタウエイト 47t、アウトリガ張出幅 8.3m ※印はアタッチメント付きの値です。 ※※印は後方限定の値です。



ATF220G-5

TADANO ATF220G-5

■定格総荷重表

●C性能 7段ESPブーム

(単位: t)

Table with columns for boom length (1-10), boom radius (1-10), and various load capacity values (e.g., 180.0, 162.8, 108.0, 60.3, etc.). Includes sub-sections for boom length, boom radius, and boom weight.

注) カウンタウエイト 35t、アウトリガ張出幅 8.3m ※印はアタッチメント付きの値です。 ※※印は後方限定の値です。

●D性能 7段ESPブーム

(単位: t)

Table with columns for boom length (1-10), boom radius (1-10), and various load capacity values (e.g., 180.0, 158.2, 108.0, 60.3, etc.). Includes sub-sections for boom length, boom radius, and boom weight.

注) カウンタウエイト 23.5t、アウトリガ張出幅 8.3m ※印はアタッチメント付きの値です。 ※※印は後方限定の値です。



ATF220G-5

TADANO ATF220G-5

■定格総荷重表

●E性能 7段ESPブーム

(単位: t)

Table with columns for boom length (1-14), boom radius (2.5-30.0), and various performance metrics. Includes sub-tables for boom extension and maximum load capacity.

注) カウンタウエイト 12t、アウトリガ張出幅 8.3m ※印はアタッチメント付きの値です。 ※※印は後方限定の値です。

●F性能 7段ESPブーム

(単位: t)

Table with columns for boom length (1-14), boom radius (2.5-30.0), and various performance metrics. Includes sub-tables for boom extension and maximum load capacity.

注) カウンタウエイト 0t、アウトリガ張出幅 8.3m ※印はアタッチメント付きの値です。 ※※印は後方限定の値です。



ATF220G-5

TADANO ATF220G-5

■定格総荷重表

●G性能 7段ESPブーム

(単位: t)

Table with columns for boom length (1-14), height (1-9), and load capacity. Includes sub-tables for boom length, height, and weight.

注) カウンタウエイト 71t、アウトリガ張出幅 7.0m ※印はアタッチメント付きの値です。 ※※印は後方限定の値です。

●H性能 7段ESPブーム

(単位: t)

Table with columns for boom length (1-14), height (1-9), and load capacity. Includes sub-tables for boom length, height, and weight.

注) カウンタウエイト 47t、アウトリガ張出幅 7.0m ※印はアタッチメント付きの値です。 ※※印は後方限定の値です。



ATF220G-5

TADANO ATF220G-5

■定格総荷重表

●I性能 7段ESPブーム

(単位: t)

Table with columns for boom length, boom radius, and load capacity across various configurations. Includes sub-tables for boom length and boom radius.

注)カウンタウエイト 35t、アウトリガ張出幅 7.0m ※印はアタッチメント付きの値です。 ※※印は後方限定の値です。

●J性能 7段ESPブーム

(単位: t)

Table with columns for boom length, boom radius, and load capacity across various configurations. Includes sub-tables for boom length and boom radius.

注)カウンタウエイト 23.5t、アウトリガ張出幅 7.0m ※印はアタッチメント付きの値です。 ※※印は後方限定の値です。



TADANO ATF220G-5

■定格総荷重表

●K性能 7段ESP ブーム

(単位: t)

Table with columns for boom length (m), boom radius (m), and various load capacities (e.g., 2.5, 3.0, 3.5, 4.0, 4.5, 5.0, 6.0, 7.0, 8.0, 9.0, 10.0, 11.0, 12.0, 14.0, 16.0, 18.0, 20.0, 22.0, 24.0, 26.0, 28.0, 30.0, 32.0, 34.0, 36.0) and rows for different boom configurations (伸縮ブーム1-6, 標準フック, フック質量, 標準吊掛本数).

注) カウンタウエイト 12t、アウトリガ張出幅 7.0m ※印はアタッチメント付きの値です。 ※※印は後方限定の値です。

●L性能 7段ESP ブーム

(単位: t)

Table with columns for boom length (m), boom radius (m), and various load capacities (e.g., 2.5, 3.0, 3.5, 4.0, 4.5, 5.0, 6.0, 7.0, 8.0, 9.0, 10.0, 11.0, 12.0, 14.0, 16.0, 18.0, 20.0, 22.0, 24.0, 26.0, 28.0, 30.0) and rows for different boom configurations (伸縮ブーム1-6, 標準フック, フック質量, 標準吊掛本数).

注) カウンタウエイト 0t、アウトリガ張出幅 7.0m ※印はアタッチメント付きの値です。 ※※印は後方限定の値です。



TADANO ATF220G-5

■定格総荷重表

●M性能 7段 ESP ブーム

(単位: t)

Table with columns for boom length, boom radius, and various load capacities (e.g., 2.5, 3.0, 3.5, 4.0, 4.5, 5.0, 6.0, 7.0, 8.0, 9.0, 10.0, 11.0, 12.0, 14.0, 16.0, 18.0, 20.0, 22.0, 24.0, 26.0, 28.0, 30.0, 32.0, 34.0, 36.0, 38.0, 40.0, 42.0, 44.0). Includes a section for boom extension ratios.

注)カウンタウエイト 35t、アウトリガ張出幅 5.6m ※印はアタッチメント付きの値です。 ※※印は後方限定の値です。

●N性能 7段 ESP ブーム

(単位: t)

Table with columns for boom length, boom radius, and various load capacities (e.g., 2.5, 3.0, 3.5, 4.0, 4.5, 5.0, 6.0, 7.0, 8.0, 9.0, 10.0, 11.0, 12.0, 14.0, 16.0, 18.0, 20.0, 22.0, 24.0, 26.0, 28.0, 30.0, 32.0, 34.0, 36.0, 38.0, 40.0, 42.0, 44.0). Includes a section for boom extension ratios.

注)カウンタウエイト 23.5t、アウトリガ張出幅 5.6m ※印はアタッチメント付きの値です。 ※※印は後方限定の値です。



ATF220G-5

TADANO ATF220G-5

■定格総荷重表

●Q性能 7段ESPブーム

(単位: t)

Table with columns for boom length, radius, and various load capacities (e.g., 2.5, 3.0, 3.5, 4.0, 4.5, 5.0, 6.0, 7.0, 8.0, 9.0, 10.0, 11.0, 12.0, 14.0, 16.0, 18.0, 20.0, 22.0, 24.0, 26.0). Includes sub-tables for extension ratios and hook weights.

注) カウンタウエイト 12t、アウトリガ張出幅 4.6m ※印はアタッチメント付きの値です。 ※※印は後方限定の値です。

●R性能 7段ESPブーム

(単位: t)

Table with columns for boom length, radius, and various load capacities (e.g., 3.0, 3.5, 4.0, 4.5, 5.0, 6.0, 7.0, 8.0, 9.0, 10.0, 11.0, 12.0, 14.0, 16.0, 18.0, 20.0). Includes sub-tables for extension ratios and hook weights.

注) カウンタウエイト 0t、アウトリガ張出幅 4.6m

※印はアタッチメント付きの値です。

●S性能 7段ESPブーム

(単位: t)

Table with columns for boom length, radius, and various load capacities (e.g., 2.5, 3.0, 3.5, 4.0, 4.5, 5.0, 6.0, 7.0, 8.0, 9.0, 10.0, 11.0, 12.0, 14.0, 16.0, 18.0, 20.0, 22.0, 24.0, 26.0). Includes sub-tables for extension ratios and hook weights.

注) カウンタウエイト 0t、アウトリガ張出幅 2.74m

●T性能 7段ESPブーム

(単位: t)

Table with columns for boom length, radius, and various load capacities (e.g., 2.5, 3.0, 3.5, 4.0, 4.5, 5.0, 6.0, 7.0, 8.0, 9.0, 10.0, 11.0, 12.0). Includes sub-tables for extension ratios and hook weights.

注) カウンタウエイト 0t、アウトリガ張出幅 2.74m

TADANO ATF220G-5

■作業範囲図

55.0mブーム+1.85m+フルオートラフィングジブ

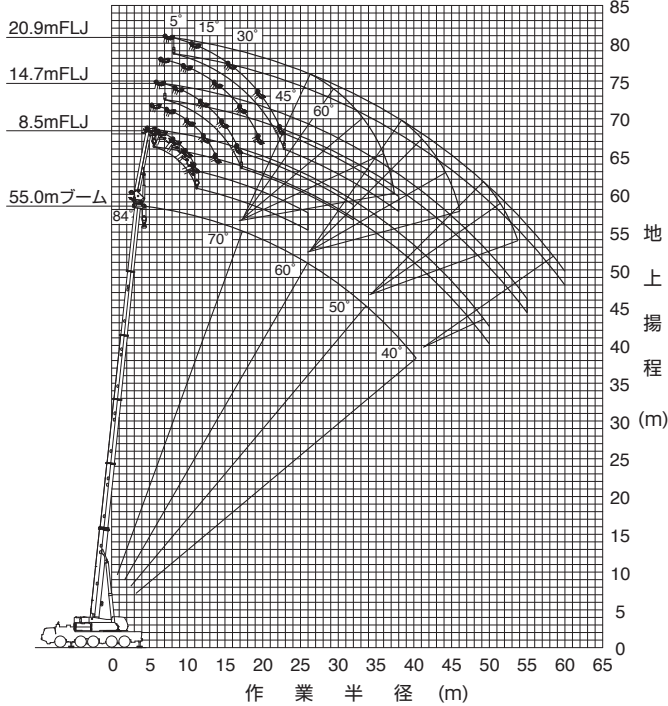

59.2mブーム+1.85m+フルオートラフィングジブ

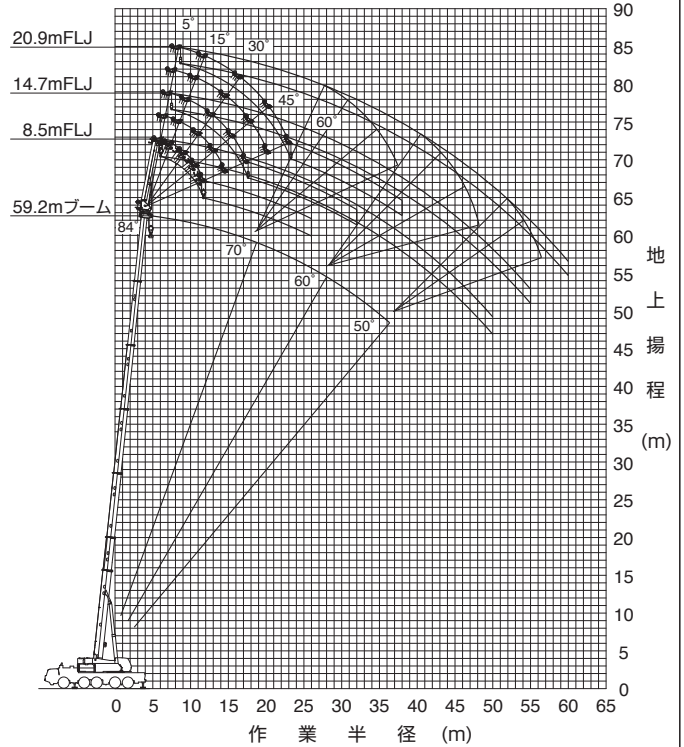

63.4mブーム+1.85m+フルオートラフィングジブ

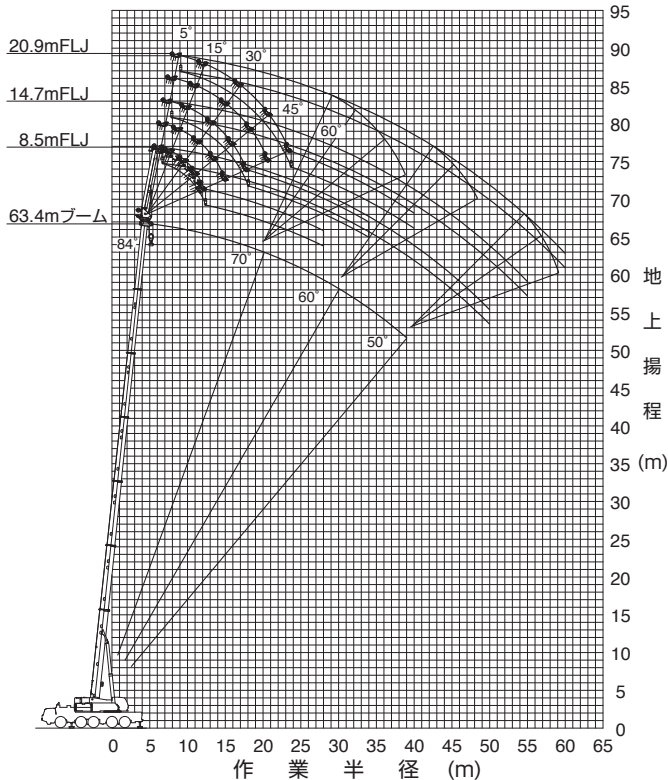

■定格総荷重表注意事項

1. 定格総荷重表の性能区分FA~FMは、下表のとおりです。

アウトリガ張出幅	カウンタウエイト					
	71t	47t	35t	23.5t	12t	0t
8.3m	FA	FB	FC	FD	FE	FF
7.0m	FG	FH	FI	FJ	FK	
5.6m			FL	FM		

2. 定格総荷重は、つり具質量とフック質量(80tフック:1,150kg、25tフック:450kg、7.8tフック:300kg)を含んだ値を示します。

3. 定格総荷重は、ブーム、ジブのたわみを含んだ実際の作業半径に基づいています。

4. 各ブーム長さにおける各ブーム段の伸縮状態(伸長割合%)は、下表のとおりです。

ブーム長さ	30.0m	34.1m	38.3m	42.5m	46.7m	50.9m	55.0m	59.2m	63.4m
伸縮ブーム1	92	92	92	92	92	92	92	92	92
伸縮ブーム2	92	92	92	92	92	92	92	92	92
伸縮ブーム3	0	46	92	92	92	92	92	92	92
伸縮ブーム4	0	0	0	46	92	92	92	92	92
伸縮ブーム5	0	0	0	0	0	46	92	92	92
伸縮ブーム6	0	0	0	0	0	0	0	46	92

5. 定格総荷重表中の標準巻掛本数よりも少ない本数で使用する場合、ロープ1本当たりの荷重は7.8t以下です。

6. Bピン(ブーム固定ピン)を挿入していないときの定格総荷重は24.0t以下になります。

7. 定格総荷重は、アウトリガを水平堅土上に設置したときの値です。

8. 定格総荷重表は、風による影響を含んでいません。

瞬間最大風速が10m/s以上(63.4mブーム時は瞬間最大風速が7m/s以上)の風速では、クレーン作業を中止してください。

9. 定格総荷重表中の太線より上側はクレーンの強度に、下側はクレーンの安定に基づいています。

10.「θ(°)」は、無負荷状態で可能なブーム起伏角度範囲を示します。

(注) 1. 上図はブームおよびジブのたわみを含んでいません。
2. FA性能の最大作業半径を図示しています。

縮尺 1/1000

TADANO ATF220G-5

■定格総荷重表

●FA性能 55.0mブーム+1.85m+フルオートラフィングジブ

(単位:t)

ジブ長さ 作業半径 (m)	8.5m					11.6m					14.7m					17.8m					20.9m					
	オフセット					オフセット					オフセット					オフセット					オフセット					
	5°	15°	30°	45°	60°	5°	15°	30°	45°	60°	5°	15°	30°	45°	60°	5°	15°	30°	45°	60°	5°	15°	30°	45°	60°	
11.0	11.5																									
12.0	11.5	11.5				10.0																				
14.0	11.5	11.5	11.4			10.0	10.0				6.9					6.7										
16.0	11.2	11.0	10.6	10.4	10.4	10.0	9.9	9.7			6.9					6.7							5.6			
18.0	10.5	10.2	9.9	9.7	9.7	9.6	9.5	9.1	8.9		6.9	6.9				6.7	6.7						5.6			
20.0	9.8	9.6	9.3	9.1	9.1	9.3	8.9	8.6	8.4	8.4	6.9	6.9	6.9			6.7	6.7					5.6	5.6			
22.0	9.2	9.0	8.7	8.6	8.6	8.7	8.4	8.1	8.0	8.0	6.9	6.9	6.9	6.9		6.7	6.7	6.3				5.6	5.6			
24.0	8.5	8.4	8.2	8.1	8.1	8.1	7.9	7.6	7.5	7.5	6.9	6.9	6.9	6.9	6.4	6.7	6.7	6.1	5.6			5.6	5.6	5.0		
26.0	7.9	7.8	7.7	7.6	7.6	7.6	7.4	7.2	7.1	7.1	6.9	6.9	6.7	6.6	6.3	6.6	6.5	5.9	5.5	5.1		5.6	5.6	4.8		
28.0	7.3	7.3	7.2	7.2		7.1	7.0	6.8	6.7	6.7	6.7	6.5	6.3	6.2	6.2	6.4	6.2	5.8	5.4	5.0		5.6	5.4	4.7	4.3	
30.0	6.8	6.8	6.7	6.7		6.6	6.6	6.4	6.4		6.3	6.2	6.0	5.9	5.9	6.0	5.9	5.6	5.2	4.9		5.5	5.2	4.6	4.2	3.9
32.0	6.3	6.3	6.3	6.3		6.2	6.2	6.1	6.1		6.0	5.8	5.7	5.6	5.6	5.7	5.5	5.4	5.1	4.9		5.3	5.0	4.4	4.1	3.8
34.0	5.9	5.9	5.9	5.9		5.8	5.8	5.8	5.7		5.6	5.5	5.4	5.3		5.4	5.3	5.1	5.0	4.9		5.2	4.9	4.3	4.0	3.8
36.0	5.5	5.5	5.5	5.5		5.4	5.4	5.4	5.4		5.2	5.2	5.1	5.1		5.1	5.0	4.9	4.8			4.9	4.7	4.2	4.0	3.7
38.0	5.1	5.1	5.1	5.1		5.1	5.0	5.0	5.1		4.9	4.9	4.9	4.8		4.8	4.8	4.6	4.6			4.7	4.5	4.1	3.9	3.7
40.0	4.7	4.8	4.8			4.7	4.7	4.7	4.7		4.6	4.6	4.6	4.6		4.5	4.5	4.4	4.4			4.4	4.3	4.0	3.8	
42.0	4.1	4.1	4.3			4.4	4.4	4.4			4.3	4.3	4.3	4.3		4.2	4.2	4.2	4.2			4.2	4.1	3.9	3.7	
44.0	3.5	3.6	3.7			3.8	4.0	4.1			4.0	4.0	4.0	4.1		4.0	4.0	4.0	4.0			3.9	3.9	3.8	3.7	
46.0	2.8	3.0	3.1			3.3	3.4	3.6			3.5	3.8	3.8			3.7	3.7	3.8	3.8			3.7	3.7	3.7	3.6	
48.0	2.1	2.2	2.4			2.7	2.9	3.1			3.3	3.3	3.6			3.5	3.5	3.5				3.5	3.5	3.5	3.5	
50.0	1.4	1.5				2.0	2.2	2.5			2.8	3.0	3.1			3.1	3.2	3.3				3.3	3.3	3.3	3.4	
55.0											1.3	1.5	1.7			1.8	2.1	2.4				2.3	2.5	2.7		
60.0																						1.1	1.4	1.7		
θ(°)	38~84	38~84	40~84	55~84	69~84	41~84	42~84	40~84	55~84	69~84	38~84	40~84	40~84	55~84	69~84	41~84	43~84	40~84	55~84	69~84	38~84	41~84	40~84	55~84	69~84	
標準フック	25t										7.8t															
フック質量	450kg										300kg															
標準巻掛本数	2										1															

注)カウンタウエイト7t、アウトリガ張出幅8.3m

ATF220G-5

●FA性能 59.2mブーム+1.85m+フルオートラフィングジブ

(単位:t)

ジブ長さ 作業半径 (m)	8.5m					11.6m					14.7m					17.8m					20.9m					
	オフセット					オフセット					オフセット					オフセット					オフセット					
	5°	15°	30°	45°	60°	5°	15°	30°	45°	60°	5°	15°	30°	45°	60°	5°	15°	30°	45°	60°	5°	15°	30°	45°	60°	
11.0	9.6																									
12.0	9.6	9.4				7.5										5.7										
14.0	9.0	8.7	8.3			7.5	7.5				6.5					5.7										
16.0	8.4	8.3	7.7	7.5		7.5	7.4				6.5	6.5				5.7							5.0			
18.0	8.1	7.8	7.3	7.1	7.0	7.2	6.9	6.5			6.5	6.3				5.7	5.7						5.0			
20.0	7.5	7.3	6.9	6.7	6.6	7.0	6.5	6.1	5.9		6.3	6.0	5.5			5.7	5.5					5.0	5.0			
22.0	7.1	6.8	6.6	6.3	6.3	6.5	6.2	5.8	5.6	5.5	5.9	5.6	5.2	5.0		5.5	5.2	4.8				5.0	4.8			
24.0	6.6	6.4	6.2	6.0	6.0	6.1	5.9	5.5	5.3	5.3	5.7	5.3	5.0	4.8	4.7	5.2	4.9	4.6				4.8	4.5	4.2		
26.0	6.2	6.0	5.8	5.7	5.7	5.8	5.6	5.2	5.0	5.0	5.4	5.1	4.8	4.6	4.5	5.0	4.7	4.4	4.2			4.6	4.3	4.0		
28.0	5.9	5.7	5.5	5.4		5.4	5.2	5.0	4.8	4.8	5.1	4.8	4.5	4.4	4.3	4.8	4.4	4.2	4.0	3.9		4.3	4.1	3.8	3.6	
30.0	5.5	5.4	5.2	5.1		5.1	5.0	4.8	4.6		4.8	4.6	4.3	4.2	4.2	4.5	4.2	4.0	3.8	3.8		4.2	3.9	3.6	3.5	
32.0	5.2	5.1	4.9	4.9		4.9	4.7	4.5	4.4		4.5	4.4	4.1	4.0	4.0	4.3	4.0	3.8	3.7	3.6		4.0	3.7	3.5	3.3	3.3
34.0	4.9	4.8	4.7	4.6		4.6	4.4	4.3	4.2		4.3	4.1	3.9	3.8		4.1	3.9	3.6	3.5	3.5		3.8	3.5	3.3	3.2	3.2
36.0	4.7	4.6	4.4	4.4		4.3	4.2	4.1	4.0		4.1	3.9	3.8	3.7		3.8	3.7	3.4	3.3			3.6	3.4	3.2	3.1	3.1
38.0	4.4	4.3	4.2	4.2		4.1	4.0	3.9	3.8		3.9	3.7	3.6	3.5		3.6	3.5	3.3	3.2			3.4	3.2	3.0	3.0	3.0
40.0	4.1	4.1	4.0			3.9	3.8	3.7	3.7		3.7	3.5	3.4	3.4		3.5	3.3	3.2	3.1			3.3	3.1	2.9	2.8	
42.0	3.8	3.8	3.8			3.7	3.6	3.5	3.5		3.5	3.4	3.3	3.2		3.3	3.2	3.1	3.0			3.1	3.0	2.8	2.7	
44.0	3.3	3.3	3.6			3.5	3.4	3.4			3.3	3.2	3.1	3.1		3.1	3.0	2.9	2.9			2.9	2.8	2.7	2.6	
46.0	2.9	3.0	3.1			3.1	3.3	3.2			3.2	3.1	3.0			3.0	2.9	2.8	2.8			2.8	2.7	2.6	2.5	
48.0	2.4	2.6	2.6			2.8	2.9	3.1			2.8	2.9	2.8			2.8	2.7	2.7	2.6			2.7	2.6	2.5	2.4	
50.0	1.7	1.9	2.0			2.5	2.6	2.7			2.6	2.6	2.7			2.7	2.6	2.5				2.5	2.5	2.4	2.4	
55.0						1.0	1.2				1.5	1.8	2.0			2.0	2.2	2.1				2.1	2.2	2.1		
60.0																						1.3	1.6	1.8		
θ(°)	42~84	43~84	43~84	57~84	70~84	39~84	40~84	43~84	57~84	70~84	42~84	44~84	43~84	57~84	70~84	45~84	41~84	43~84	57~84	70~84	42~84	44~84	43~84	57~84	70~84	
標準フック	25t										7.8t															
フック質量	450kg										300kg															
標準巻掛本数	2										1															

注)カウンタウエイト7t、アウトリガ張出幅8.3m

TADANO ATF220G-5

■定格総荷重表

●FA性能 63.4mブーム+1.85m+フルオートラフィングジブ

(単位：t)

ジブ長さ 作業半径 (m)	8.5m					11.6m					14.7m					17.8m					20.9m									
	オフセット					オフセット					オフセット					オフセット					オフセット									
	5°	15°	30°	45°	60°	5°	15°	30°	45°	60°	5°	15°	30°	45°	60°	5°	15°	30°	45°	60°	5°	15°	30°	45°	60°					
14.0	7.0	7.0				6.1					5.4																			
16.0	6.8	6.6	6.3			6.1	6.0				5.4										4.7									
18.0	6.3	6.1	5.9	5.7		5.9	5.7	5.3			5.4	5.2									4.7			4.2						
20.0	6.0	5.8	5.5	5.3	5.3	5.5	5.3	5.0	4.8		5.2	4.9									4.7	4.5		4.2						
22.0	5.6	5.4	5.1	5.0	5.0	5.2	5.0	4.7	4.5	4.5	4.8	4.6	4.3								4.6	4.3		4.2	4.0					
24.0	5.3	5.1	4.8	4.7	4.7	4.9	4.7	4.4	4.3	4.2	4.5	4.3	4.1	3.9							4.3	4.0	3.8		4.0	3.7				
26.0	4.9	4.8	4.6	4.4	4.4	4.6	4.4	4.2	4.1	4.0	4.3	4.1	3.9	3.7	3.7						4.0	3.8	3.6		3.8	3.5	3.3			
28.0	4.6	4.5	4.3	4.2	4.2	4.3	4.1	3.9	3.9	3.8	4.0	3.8	3.6	3.5	3.5						3.8	3.6	3.4	3.3	3.2	3.6	3.4	3.1		
30.0	4.3	4.2	4.1	4.0		4.1	3.9	3.7	3.6	3.6	3.8	3.6	3.5	3.3	3.3						3.6	3.4	3.2	3.1	3.1	3.3	3.2	3.0	2.9	
32.0	4.0	4.0	3.9	3.8		3.8	3.7	3.5	3.4		3.6	3.4	3.3	3.2	3.2						3.4	3.2	3.0	2.9	2.9	3.2	3.0	2.8	2.7	2.7
34.0	3.8	3.7	3.6	3.6		3.6	3.5	3.3	3.3		3.4	3.2	3.1	3.0	3.0						3.2	3.0	2.9	2.8	2.8	3.0	2.9	2.7	2.6	2.6
36.0	3.6	3.5	3.4	3.4		3.4	3.3	3.2	3.1		3.2	3.1	2.9	2.8							3.0	2.9	2.7	2.7	2.6	2.8	2.7	2.6	2.5	2.4
38.0	3.3	3.3	3.2	3.2		3.2	3.1	3.0	2.9		3.0	2.9	2.8	2.7							2.9	2.7	2.6	2.5		2.7	2.5	2.4	2.3	2.3
40.0	3.1	3.1	3.0	3.0		3.0	2.9	2.8	2.8		2.8	2.8	2.6	2.6							2.7	2.6	2.4	2.4		2.5	2.4	2.3	2.2	2.2
42.0	3.0	2.9	2.8			2.8	2.7	2.7	2.6		2.7	2.6	2.5	2.4							2.5	2.4	2.3	2.3		2.4	2.3	2.2	2.1	
44.0	2.8	2.7	2.7			2.6	2.6	2.5	2.5		2.5	2.4	2.4	2.3							2.4	2.3	2.2	2.1		2.3	2.2	2.0	2.0	
46.0	2.4	2.6	2.5			2.5	2.4	2.4			2.4	2.3	2.3	2.2							2.3	2.2	2.1	2.0		2.2	2.1	1.9	1.9	
48.0	2.3	2.3	2.2			2.2	2.3	2.2			2.2	2.2	2.1								2.1	2.1	2.0	2.0		2.0	2.0	1.8	1.8	
50.0	2.1	2.1	2.1			2.0	2.0	2.1			2.1	2.0	2.0								2.0	1.9	1.9	1.9		1.9	1.9	1.8	1.7	
55.0						1.3	1.5	1.7			1.6	1.6	1.6								1.6	1.7	1.6			1.6	1.6	1.6		
60.0																					1.0	1.3	1.3			1.3	1.2	1.3		
θ(°)	46~84	47~84	45~84	57~84	70~84	43~84	44~84	45~84	57~84	70~84	46~84	47~84	45~84	57~84	70~84	43~84	44~84	45~84	57~84	70~84	45~84	47~84	45~84	57~84	70~84	45~84	47~84	45~84	57~84	70~84
標準フック																7.8t														
フック質量																300kg														
標準巻掛本数																1														

注)カウンタウエイト 71t、アウトリガ張出幅 8.3m

ATF220G-5

●FB性能 55.0mブーム+1.85m+フルオートラフィングジブ

(単位：t)

ジブ長さ 作業半径 (m)	8.5m				11.6m				14.7m				17.8m				20.9m														
	オフセット				オフセット				オフセット				オフセット				オフセット														
	5°	15°	30°	45°	60°	5°	15°	30°	45°	60°	5°	15°	30°	45°	60°	5°	15°	30°	45°	60°	5°	15°	30°	45°	60°						
11.0	11.5																														
12.0	11.5	11.5				10.0																									
14.0	11.5	11.5	11.4			10.0	10.0				6.9										6.7										
16.0	11.2	11.0	10.6	10.4	10.4	10.0	9.9	9.7			6.9										6.7					5.6					
18.0	10.5	10.2	9.9	9.7	9.7	9.6	9.5	9.1	8.9		6.9	6.9								6.7	6.7				5.6						
20.0	9.8	9.6	9.3	9.1	9.1	9.3	8.9	8.6	8.4	8.4	6.9	6.9	6.9							6.7	6.7				5.6	5.6					
22.0	9.2	9.0	8.7	8.6	8.6	8.7	8.4	8.1	8.0	8.0	6.9	6.9	6.9	6.9						6.7	6.7	6.3			5.6	5.6					
24.0	8.5	8.4	8.2	8.1	8.1	8.1	7.9	7.6	7.5	7.5	6.9	6.9	6.9	6.9	6.4					6.7	6.7	6.1	5.6		5.6	5.6	5.0				
26.0	7.9	7.8	7.7	7.6	7.6	7.6	7.4	7.2	7.1	7.1	6.9	6.9	6.7	6.6	6.3					6.6	6.5	5.9	5.5	5.1	5.6	5.6	4.8				
28.0	7.3	7.3	7.2	7.2		7.1	7.0	6.8	6.7	6.7	6.7	6.5	6.3	6.2	6.2	6.4				6.4	6.2	5.8	5.4	5.0	5.6	5.4	4.7	4.3			
30.0	6.8	6.8	6.7	6.7		6.6	6.6	6.4	6.4		6.3	6.2	6.0	5.9	5.9	6.0				6.0	5.9	5.6	5.2	4.9	5.5	5.2	4.6	4.2	3.9		
32.0	5.6	6.0	6.3	6.3		6.2	6.2	6.1	6.1		6.0	5.8	5.7	5.6	5.6	5.7				5.7	5.5	5.4	5.1	4.9	5.3	5.0	4.4	4.1	3.8		
34.0	4.3	4.7	5.1	5.4		5.0	5.5	5.8	5.7		5.6	5.5	5.4	5.3						5.4	5.3	5.1	5.0	4.9	5.2	4.9	4.3	4.0	3.8		
36.0	3.2	3.6	4.0	4.2		3.9	4.4	5.0	5.3		4.8	5.2	5.1	5.1						5.1	5.0	4.9	4.8		4.9	4.7	4.2	4.0	3.7		
38.0	2.3	2.6	2.9	3.1		2.9	3.4	3.9	4.2		3.8	4.3	4.9	4.8						4.3	4.8	4.6	4.6		4.7	4.5	4.1	3.9	3.7		
40.0		1.7	2.0			2.1	2.5	2.9	3.2		2.9	3.4	4.0	4.4						3.4	4.0	4.4	4.4		4.0	4.3	4.0	3.8			
42.0							1.7	2.1			2.1	2.6	3.1	3.5						2.6	3.2	3.9	4.2		3.2	3.8	3.9	3.7			
44.0											1.4	1.8	2.3	2.6						1.9	2.4	3.1	3.5		2.4	3.1	3.8	3.7			
46.0													1.6								1.7	2.3	2.6		1.8	2.4	3.1	3.6			
48.0																						1.6				1.7	2.4	2.4	2.8		
50.0																											1.7	2.1			
θ(°)	53~84	52~84	53~84	55~84	69~84	53~84	52~84	54~84	55~84	69~84	51~84	53~84	53~84	55~84	69~84	53~84	53~84	53~84	55~84	69~84	53~84	53~84	53~84	55~84	69~84	53~84	54~84	54~84	55~84	69~84	
標準フック																25t															
フック質量																450kg															
標準巻掛本数																2															

注)カウンタウエイト 47t、アウトリガ張出幅 8.3m

TADANO ATF220G-5

■定格総荷重表

●FB性能 59.2mブーム+1.85m+フルオートラフィングジブ

(単位:t)

ジブ長さ 作業半径 (m)	8.5m					11.6m					14.7m					17.8m					20.9m				
	オフセット					オフセット					オフセット					オフセット					オフセット				
	5°	15°	30°	45°	60°	5°	15°	30°	45°	60°	5°	15°	30°	45°	60°	5°	15°	30°	45°	60°	5°	15°	30°	45°	60°
11.0	9.6																								
12.0	9.6	9.4				7.5																			
14.0	9.0	8.7	8.3			7.5	7.5				6.5					5.7									
16.0	8.4	8.3	7.7	7.5		7.5	7.4				6.5	6.5				5.7					5.0				
18.0	8.1	7.8	7.3	7.1	7.0	7.2	6.9	6.5			6.5	6.3				5.7	5.7				5.0				
20.0	7.5	7.3	6.9	6.7	6.6	7.0	6.5	6.1	5.9		6.3	6.0	5.5			5.7	5.5				5.0	5.0			
22.0	7.1	6.8	6.6	6.3	6.3	6.5	6.2	5.8	5.6	5.5	5.9	5.6	5.2	5.0		5.5	5.2	4.8			5.0	4.8			
24.0	6.6	6.4	6.2	6.0	6.0	6.1	5.9	5.5	5.3	5.3	5.7	5.3	5.0	4.8	4.7	5.2	4.9	4.6			4.8	4.5	4.2		
26.0	6.2	6.0	5.8	5.7	5.7	5.8	5.6	5.2	5.0	5.0	5.4	5.1	4.8	4.6	4.5	5.0	4.7	4.4	4.2		4.6	4.3	4.0		
28.0	5.9	5.7	5.5	5.4		5.4	5.2	5.0	4.8	4.8	5.1	4.8	4.5	4.4	4.3	4.8	4.4	4.2	4.0	3.9	4.3	4.1	3.8	3.6	
30.0	5.5	5.4	5.2	5.1		5.1	5.0	4.8	4.6		4.8	4.6	4.3	4.2	4.2	4.5	4.2	4.0	3.8	3.8	4.2	3.9	3.6	3.5	
32.0	5.2	5.1	4.9	4.9		4.9	4.7	4.5	4.4		4.5	4.4	4.1	4.0	4.0	4.3	4.0	3.8	3.7	3.6	4.0	3.7	3.5	3.3	3.3
34.0	4.7	4.8	4.7	4.6		4.6	4.4	4.3	4.2		4.3	4.1	3.9	3.8		4.1	3.9	3.6	3.5	3.5	3.8	3.5	3.3	3.2	3.2
36.0	3.6	3.9	4.3	4.4		4.3	4.2	4.1	4.0		4.1	3.9	3.8	3.7		3.8	3.7	3.4	3.3		3.6	3.4	3.2	3.1	3.1
38.0	2.6	2.9	3.3	3.5		3.5	3.9	3.9	3.8		3.9	3.7	3.6	3.5		3.6	3.5	3.3	3.2		3.4	3.2	3.0	3.0	3.0
40.0		2.0	2.3			2.6	3.0	3.5	3.7		3.1	3.5	3.4	3.4		3.5	3.3	3.2	3.1		3.3	3.1	2.9	2.8	
42.0						1.8	2.2	2.6	2.8		2.3	2.8	3.3	3.2		2.8	3.2	3.1	3.0		3.1	3.0	2.8	2.7	
44.0								1.8			1.6	2.1	2.6	2.9		2.1	2.6	2.9	2.9		2.6	2.8	2.7	2.6	
46.0													1.9			1.9	2.5	2.8	2.8		2.0	2.5	2.6	2.5	
48.0																	1.9	2.2				1.9	2.5	2.4	
50.0																						1.9	2.4		
θ(°)	55~84	54~84	55~84	57~84	70~84	54~84	55~84	54~84	57~84	70~84	54~84	55~84	55~84	57~84	70~84	55~84	56~84	56~84	57~84	70~84	56~84	56~84	57~84	57~84	70~84
標準フック	25t										7.8t														
フック質量	450kg										300kg														
標準巻掛本数	2										1														

注)カウンタウエイト 47t、アウトリガ張出幅 8.3m

ATF220G-5

●FB性能 63.4mブーム+1.85m+フルオートラフィングジブ

(単位:t)

ジブ長さ 作業半径 (m)	8.5m					11.6m					14.7m					17.8m					20.9m				
	オフセット					オフセット					オフセット					オフセット					オフセット				
	5°	15°	30°	45°	60°	5°	15°	30°	45°	60°	5°	15°	30°	45°	60°	5°	15°	30°	45°	60°	5°	15°	30°	45°	60°
14.0	7.0	7.0				6.1					5.4														
16.0	6.8	6.6	6.3			6.1	6.0				5.4					4.7									
18.0	6.3	6.1	5.9	5.7		5.9	5.7	5.3			5.4	5.2				4.7									
20.0	6.0	5.8	5.5	5.3	5.3	5.5	5.3	5.0	4.8		5.2	4.9				4.7	4.5								
22.0	5.6	5.4	5.1	5.0	5.0	5.2	5.0	4.7	4.5	4.5	4.8	4.6	4.3			4.6	4.3								
24.0	5.3	5.1	4.8	4.7	4.7	4.9	4.7	4.4	4.3	4.2	4.5	4.3	4.1	3.9		4.3	4.0	3.8							
26.0	4.9	4.8	4.6	4.4	4.4	4.6	4.4	4.2	4.1	4.0	4.3	4.1	3.9	3.7	3.7	4.0	3.8	3.6							
28.0	4.6	4.5	4.3	4.2	4.2	4.3	4.1	3.9	3.9	3.8	4.0	3.8	3.6	3.5	3.5	3.8	3.6	3.4	3.3	3.2	3.6	3.4	3.1		
30.0	4.3	4.2	4.1	4.0		4.1	3.9	3.7	3.6	3.6	3.8	3.6	3.5	3.3	3.3	3.6	3.4	3.2	3.1	3.1	3.3	3.2	3.0	2.9	
32.0	4.0	4.0	3.9	3.8		3.8	3.7	3.5	3.4		3.6	3.4	3.3	3.2	3.2	3.4	3.2	3.0	2.9	2.9	3.2	3.0	2.8	2.7	2.7
34.0	3.8	3.7	3.6	3.6		3.6	3.5	3.3	3.3		3.4	3.2	3.1	3.0	3.0	3.2	3.0	2.9	2.8	2.8	3.0	2.9	2.7	2.6	2.6
36.0	3.6	3.5	3.4	3.4		3.4	3.3	3.2	3.1		3.2	3.1	2.9	2.8		3.0	2.9	2.7	2.7	2.6	2.8	2.7	2.6	2.5	2.4
38.0	3.1	3.3	3.2	3.2		3.2	3.1	3.0	2.9		3.0	2.9	2.8	2.7		2.9	2.7	2.6	2.5		2.7	2.5	2.4	2.3	2.3
40.0	2.3	2.6	2.9	3.0		2.8	2.9	2.8	2.8		2.8	2.8	2.6	2.6		2.7	2.6	2.4	2.4		2.5	2.4	2.3	2.2	2.2
42.0		1.7	2.0			2.1	2.4	2.7	2.6		2.6	2.6	2.5	2.4		2.5	2.4	2.3	2.3		2.4	2.3	2.2	2.1	
44.0								2.1	2.3		1.9	2.3	2.4	2.3		2.3	2.3	2.2	2.1		2.3	2.2	2.0	2.0	
46.0													2.1	2.2			2.1	2.1	2.0		2.1	2.1	1.9	1.9	
48.0																	2.0	2.0				2.0	1.8	1.8	
50.0																						1.8	1.7		
θ(°)	56~84	55~84	56~84	57~84	70~84	56~84	57~84	57~84	57~84	70~84	56~84	58~84	58~84	57~84	70~84	57~84	58~84	58~84	57~84	70~84	58~84	58~84	59~84	61~84	70~84
標準フック											7.8t														
フック質量											300kg														
標準巻掛本数											1														

注)カウンタウエイト 47t、アウトリガ張出幅 8.3m

TADANO ATF220G-5

■定格総荷重表

●FC性能 55.0mブーム+1.85m+フルオートラフィングジブ

(単位:t)

ジブ長さ 作業半径 (m)	8.5m					11.6m					14.7m					17.8m					20.9m							
	オフセット					オフセット					オフセット					オフセット					オフセット							
	5°	15°	30°	45°	60°	5°	15°	30°	45°	60°	5°	15°	30°	45°	60°	5°	15°	30°	45°	60°	5°	15°	30°	45°	60°			
11.0	11.5																											
12.0	11.5	11.5				10.0																						
14.0	11.5	11.5	11.4			10.0	10.0				6.9					6.7												
16.0	11.2	11.0	10.6	10.4	10.4	10.0	9.9	9.7			6.9					6.7								5.6				
18.0	10.5	10.2	9.9	9.7	9.7	9.6	9.5	9.1	8.9		6.9	6.9				6.7	6.7							5.6				
20.0	9.8	9.6	9.3	9.1	9.1	9.3	8.9	8.6	8.4	8.4	6.9	6.9	6.9			6.7	6.7						5.6	5.6				
22.0	9.2	9.0	8.7	8.6	8.6	8.7	8.4	8.1	8.0	8.0	6.9	6.9	6.9	6.9		6.7	6.7	6.3					5.6	5.6				
24.0	8.5	8.4	8.2	8.1	8.1	8.1	7.9	7.6	7.5	7.5	6.9	6.9	6.9	6.9	6.4	6.7	6.7	6.1	5.6				5.6	5.6	5.0			
26.0	7.4	7.8	7.7	7.6	7.6	7.6	7.4	7.2	7.1	7.1	6.9	6.9	6.7	6.6	6.3	6.6	6.5	5.9	5.5	5.1			5.6	5.6	4.8			
28.0	5.7	6.2	6.8	7.2		6.4	7.0	6.8	6.7	6.7	6.7	6.5	6.3	6.2	6.2	6.4	6.2	5.8	5.4	5.0			5.6	5.4	4.7	4.3		
30.0	4.2	4.7	5.3	5.6		5.0	5.6	6.4	6.4		5.9	6.2	6.0	5.9	5.9	6.0	5.9	5.6	5.2	4.9			5.5	5.2	4.6	4.2	3.9	
32.0	3.0	3.4	3.9	4.2		3.7	4.3	5.0	5.5		4.6	5.3	5.7	5.6	5.6	5.2	5.5	5.4	5.1	4.9			5.3	5.0	4.4	4.1	3.8	
34.0			2.7	3.0			3.1	3.8	4.2		3.5	4.2	5.0	5.3		4.0	4.8	5.1	5.0	4.9			4.6	4.9	4.3	4.0	3.8	
36.0								2.7	3.1		2.5	3.1	3.9	4.4		3.1	3.8	4.7	4.8				3.6	4.5	4.2	4.0	3.7	
38.0													2.9	3.4			2.9	3.7	4.3				2.7	3.5	4.1	3.9	3.7	
40.0														2.4				2.8	3.4					2.7	3.5	4.1	3.8	
42.0																			2.5						2.8	3.5		
44.0																									2.1	2.6		
θ(°)	59~84	60~84	59~84	60~84	69~84	61~84	61~84	60~84	61~84	69~84	59~84	61~84	61~84	60~84	69~84	61~84	61~84	62~84	61~84	69~84	61~84	61~84	60~84	62~84	69~84	69~84	69~84	
標準フック	25t										7.8t																	
フック質量	450kg										300kg																	
標準巻掛本数	2										1																	

注)カウンタウエイト 35t、アウトリガ張出幅 8.3m

ATF220G-5

●FC性能 59.2mブーム+1.85m+フルオートラフィングジブ

(単位:t)

ジブ長さ 作業半径 (m)	8.5m					11.6m					14.7m					17.8m					20.9m							
	オフセット					オフセット					オフセット					オフセット					オフセット							
	5°	15°	30°	45°	60°	5°	15°	30°	45°	60°	5°	15°	30°	45°	60°	5°	15°	30°	45°	60°	5°	15°	30°	45°	60°			
11.0	9.6																											
12.0	9.6	9.4				7.5																						
14.0	9.0	8.7	8.3			7.5	7.5				6.5					5.7												
16.0	8.4	8.3	7.7	7.5		7.5	7.4				6.5	6.5				5.7								5.0				
18.0	8.1	7.8	7.3	7.1	7.0	7.2	6.9	6.5			6.5	6.3				5.7	5.7							5.0				
20.0	7.5	7.3	6.9	6.7	6.6	7.0	6.5	6.1	5.9		6.3	6.0	5.5			5.7	5.5						5.0	5.0				
22.0	7.1	6.8	6.6	6.3	6.3	6.5	6.2	5.8	5.6	5.5	5.9	5.6	5.2	5.0		5.5	5.2	4.8					5.0	4.8				
24.0	6.6	6.4	6.2	6.0	6.0	6.1	5.9	5.5	5.3	5.3	5.7	5.3	5.0	4.8	4.7	5.2	4.9	4.6					4.8	4.5	4.2			
26.0	6.2	6.0	5.8	5.7	5.7	5.8	5.6	5.2	5.0	5.0	5.4	5.1	4.8	4.6	4.5	5.0	4.7	4.4	4.2				4.6	4.3	4.0			
28.0	5.9	5.7	5.5	5.4		5.4	5.2	5.0	4.8	4.8	5.1	4.8	4.5	4.4	4.3	4.8	4.4	4.2	4.0	3.9			4.3	4.1	3.8	3.6		
30.0	4.6	5.1	5.2	5.1		5.1	5.0	4.8	4.6		4.8	4.6	4.3	4.2	4.2	4.5	4.2	4.0	3.8	3.8			4.2	3.9	3.6	3.5		
32.0	3.4	3.8	4.3	4.6		4.3	4.7	4.5	4.4		4.5	4.4	4.1	4.0	4.0	4.3	4.0	3.8	3.7	3.6			4.0	3.7	3.5	3.3	3.3	
34.0			3.1	3.4		3.2	3.7	4.3	4.2		3.7	4.1	3.9	3.8		4.1	3.9	3.6	3.5	3.5			3.8	3.5	3.3	3.2	3.2	
36.0							2.7	3.3	3.7		2.8	3.4	3.8	3.7		3.3	3.7	3.4	3.3				3.6	3.4	3.2	3.1	3.1	
38.0									2.6				3.2	3.5			3.1	3.3	3.2				2.9	3.2	3.0	3.0	3.0	
40.0													2.7					3.0	3.1					2.9	2.9	2.8		
42.0																			2.7						2.8	2.7		
44.0																									2.3	2.6		
46.0																										2.1		
θ(°)	61~84	62~84	62~84	62~84	70~84	61~84	61~84	62~84	62~84	70~84	61~84	63~84	63~84	63~84	70~84	62~84	63~84	63~84	63~84	70~84	62~84	63~84	62~84	62~84	70~84	70~84	70~84	
標準フック	25t										7.8t																	
フック質量	450kg										300kg																	
標準巻掛本数	2										1																	

注)カウンタウエイト 35t、アウトリガ張出幅 8.3m

TADANO ATF220G-5

■定格総荷重表

●FC性能 63.4mブーム+1.85m+フルオートラフィングジブ

(単位:t)

ジブ長さ 作業半径 (m)	8.5m オフセット					11.6m オフセット					14.7m オフセット					17.8m オフセット					20.9m オフセット					
	5°	15°	30°	45°	60°	5°	15°	30°	45°	60°	5°	15°	30°	45°	60°	5°	15°	30°	45°	60°	5°	15°	30°	45°	60°	
14.0	7.0	7.0				6.1					5.4															
16.0	6.8	6.6	6.3			6.1	6.0				5.4										4.7					
18.0	6.3	6.1	5.9	5.7		5.9	5.7	5.3			5.4	5.2									4.7					
20.0	6.0	5.8	5.5	5.3	5.3	5.5	5.3	5.0	4.8		5.2	4.9									4.7	4.5				
22.0	5.6	5.4	5.1	5.0	5.0	5.2	5.0	4.7	4.5	4.5	4.8	4.6	4.3								4.6	4.3				
24.0	5.3	5.1	4.8	4.7	4.7	4.9	4.7	4.4	4.3	4.2	4.5	4.3	4.1	3.9							4.3	4.0	3.8			
26.0	4.9	4.8	4.6	4.4	4.4	4.6	4.4	4.2	4.1	4.0	4.3	4.1	3.9	3.7	3.7						4.0	3.8	3.6			
28.0	4.6	4.5	4.3	4.2	4.2	4.3	4.1	3.9	3.9	3.8	4.0	3.8	3.6	3.5	3.5	3.8	3.6	3.4	3.3	3.2	3.6	3.4	3.1			
30.0	4.3	4.2	4.1	4.0		4.1	3.9	3.7	3.6	3.6	3.8	3.6	3.5	3.3	3.3	3.6	3.4	3.2	3.1	3.1	3.3	3.2	3.0	2.9		
32.0	3.9	4.0	3.9	3.8		3.8	3.7	3.5	3.4		3.6	3.4	3.3	3.2	3.2	3.4	3.2	3.0	2.9	2.9	3.2	3.0	2.8	2.7	2.7	
34.0		3.2	3.6	3.6		3.4	3.5	3.3	3.3		3.4	3.2	3.1	3.0	3.0	3.2	3.0	2.9	2.8	2.8	3.0	2.9	2.7	2.6	2.6	
36.0				2.9			2.9	3.2	3.1		3.0	3.1	2.9	2.8		3.0	2.9	2.7	2.7	2.6	2.8	2.7	2.6	2.5	2.4	
38.0									2.9					2.8	2.7			2.7	2.6	2.5		2.7	2.5	2.4	2.3	2.3
40.0															2.6			2.4	2.4				2.4	2.3	2.2	2.2
42.0																				2.3				2.2	2.1	
44.0																								2.0	2.0	
46.0																									1.9	
θ(°)	63~84	63~84	64~84	63~84	70~84	63~84	63~84	64~84	63~84	70~84	63~84	64~84	65~84	64~84	70~84	64~84	64~84	65~84	65~84	70~84	64~84	64~84	64~84	64~84	70~84	
標準フック	7.8t																									
フック質量	300kg																									
標準巻掛本数	1																									

注)カウンタウエイト 35t、アウトリガ張出幅 8.3m

●FD性能 55.0mブーム+1.85m+フルオートラフィングジブ

(単位:t)

ジブ長さ 作業半径 (m)	8.5m オフセット					11.6m オフセット					14.7m オフセット					17.8m オフセット					20.9m オフセット								
	5°	15°	30°	45°	60°	5°	15°	30°	45°	60°	5°	15°	30°	45°	60°	5°	15°	30°	45°	60°	5°	15°	30°	45°	60°				
11.0	11.5																												
12.0	11.5	11.5				10.0																							
14.0	11.5	11.5	11.4			10.0	10.0				6.9										6.7								
16.0	11.2	11.0	10.6	10.4	10.4	10.0	9.9	9.7			6.9										6.7				5.6				
18.0	10.5	10.2	9.9	9.7	9.7	9.6	9.5	9.1	8.9		6.9	6.9									6.7	6.7			5.6				
20.0	9.8	9.6	9.3	9.1	9.1	9.3	8.9	8.6	8.4	8.4	6.9	6.9	6.9								6.7	6.7			5.6	5.6			
22.0	7.9	8.6	8.7	8.6	8.6	8.7	8.4	8.1	8.0	8.0	6.9	6.9	6.9	6.9							6.7	6.7	6.3		5.6	5.6			
24.0	5.7	6.4	7.2	7.8	8.1	6.5	7.4	7.6	7.5	7.5	6.9	6.9	6.9	6.9	6.4						6.7	6.7	6.1	5.6	5.6	5.6	5.0		
26.0			5.3	5.8	6.0	4.8	5.6	6.6	7.1	7.1	5.8	6.8	6.7	6.6	6.3	6.4					6.5	5.9	5.5	5.1	5.6	5.6	4.8		
28.0								4.9	5.6	6.0	4.2	5.2	6.3	6.2	6.2	4.8					5.9	5.8	5.4	5.0	5.5	5.4	4.7	4.3	
30.0									4.1			3.8	4.9	5.7	5.9						4.5	5.6	5.2	4.9	4.2	5.2	4.6	4.2	3.9
32.0												3.6	4.3	4.7							4.5	5.1	4.9		4.1	4.4	4.1	3.8	
34.0																					3.4	4.2	4.6			4.3	4.0	3.8	
36.0																						3.1				3.3	4.0	3.7	
38.0																										3.2	3.6		
θ(°)	67~84	68~84	68~84	69~84	69~84	67~84	68~84	68~84	68~84	69~84	66~84	67~84	67~84	69~84	69~84	68~84	68~84	67~84	67~84	69~84	67~84	68~84	68~84	68~84	68~84	68~84	69~84		
標準フック	25t																												
フック質量	450kg																												
標準巻掛本数	2																												

注)カウンタウエイト 23.5t、アウトリガ張出幅 8.3m

●FD性能 59.2mブーム+1.85m+フルオートラフィングジブ

(単位:t)

ジブ長さ 作業半径 (m)	8.5m オフセット					11.6m オフセット					14.7m オフセット					17.8m オフセット					20.9m オフセット								
	5°	15°	30°	45°	60°	5°	15°	30°	45°	60°	5°	15°	30°	45°	60°	5°	15°	30°	45°	60°	5°	15°	30°	45°	60°				
11.0	9.6																												
12.0	9.6	9.4				7.5																							
14.0	9.0	8.7	8.3			7.5	7.5				6.5										5.7								
16.0	8.4	8.3	7.7	7.5		7.5	7.4				6.5	6.5									5.7					5.0			
18.0	8.1	7.8	7.3	7.1	7.0	7.2	6.9	6.5			6.5	6.3									5.7	5.7				5.0			
20.0	7.5	7.3	6.9	6.7	6.6	7.0	6.5	6.1	5.9		6.3	6.0	5.5								5.7	5.5				5.0	5.0		
22.0	7.1	6.8	6.6	6.3	6.3	6.5	6.2	5.8	5.6	5.5	5.9	5.6	5.2	5.0							5.5	5.2	4.8			5.0	4.8		
24.0	6.1	6.4	6.2	6.0	6.0	6.1	5.9	5.5	5.3	5.3	5.7	5.3	5.0	4.8	4.7						5.2	4.9	4.6			4.8	4.5	4.2	
26.0			5.7	5.7	5.7	5.4	5.6	5.2	5.0	5.0	5.4	5.1	4.8	4.6	4.5	5.0					4.7	4.4	4.2			4.6	4.3	4.0	
28.0							4.6	5.0	4.8	4.8	4.5	4.8	4.5	4.4	4.3	4.8					4.4	4.2	4.0	3.9	4.3	4.1	3.8	3.6	
30.0								4.1	4.6			4.1	4.3	4.2	4.2						4.2	4.0	3.8	3.8	4.2	3.9	3.6	3.5	
32.0												3.9	4.0	4.0							3.8	3.7	3.6			3.7	3.5	3.3	3.3
34.0																					3.6	3.5	3.5			3.3	3.2	3.2	
36.0																						3.3					3.2	3.1	3.1
38.0																											3.0	3.0	
θ(°)	69~84	70~84	69~84	70~84	70~84	68~84	68~84	68~84	69~84	70~84	68~84	68~84	68~84	70~84	70~84	69~84	69~84	69~84	69~84	70~84	68~84	69~84	69~84	70~84	68~84	69~84	69~84	70~84	70~84
標準フック	25t																												
フック質量	450kg																												
標準巻掛本数	2																												

注)カウンタウエイト 23.5t、アウトリガ張出幅 8.3m

TADANO ATF220G-5

■定格総荷重表

●FD性能 63.4mブーム+1.85m+フルオートラフィングジブ

(単位:t)

ジブ長さ 作業半径 (m)	8.5m オフセット					11.6m オフセット					14.7m オフセット					17.8m オフセット					20.9m オフセット				
	5°	15°	30°	45°	60°	5°	15°	30°	45°	60°	5°	15°	30°	45°	60°	5°	15°	30°	45°	60°	5°	15°	30°	45°	60°
14.0	7.0	7.0				6.1					5.4					4.7									
16.0	6.8	6.6	6.3			6.1	6.0				5.4					4.7									
18.0	6.3	6.1	5.9	5.7		5.9	5.7	5.3			5.4	5.2				4.7							4.2		
20.0	6.0	5.8	5.5	5.3	5.3	5.5	5.3	5.0	4.8		5.2	4.9				4.7	4.5					4.2			
22.0	5.6	5.4	5.1	5.0	5.0	5.2	5.0	4.7	4.5	4.5	4.8	4.6	4.3			4.6	4.3					4.2	4.0		
24.0	5.3	5.1	4.8	4.7	4.7	4.9	4.7	4.4	4.3	4.2	4.5	4.3	4.1	3.9		4.3	4.0	3.8				4.0	3.7		
26.0		4.8	4.6	4.4	4.4	4.6	4.4	4.2	4.1	4.0	4.3	4.1	3.9	3.7	3.7	4.0	3.8	3.6				3.8	3.5	3.3	
28.0			4.3	4.2	4.2		4.1	3.9	3.9	3.8	4.0	3.8	3.6	3.5	3.5	3.8	3.6	3.4	3.3	3.2		3.6	3.4	3.1	
30.0								3.7	3.6	3.6			3.5	3.3	3.3		3.4	3.2	3.1	3.1		3.3	3.2	2.9	
32.0													3.3	3.2	3.2			3.0	2.9	2.9		3.0	2.8	2.7	
34.0														3.0				2.8	2.8				2.7	2.6	
36.0																			2.6				2.6	2.5	
38.0																							2.3	2.3	
θ(°)	70~84	70~84	69~84	70~84	70~84	70~84	69~84	69~84	71~84	70~84	69~84	71~84	70~84	71~84	70~84	70~84	70~84	71~84	72~84	70~84	70~84	70~84	71~84	72~84	
標準フック											7.8t														
フック質量											300kg														
標準巻掛本数											1														

注)カウンタウエイト 23.5t、アウトリガ張出幅 8.3m

●FE性能 55.0mブーム+1.85m+フルオートラフィングジブ

(単位:t)

ジブ長さ 作業半径 (m)	8.5m オフセット					11.6m オフセット					14.7m オフセット					17.8m オフセット					20.9m オフセット				
	5°	15°	30°	45°	60°	5°	15°	30°	45°	60°	5°	15°	30°	45°	60°	5°	15°	30°	45°	60°	5°	15°	30°	45°	60°
11.0	11.5					10.0																			
12.0	11.5	11.5				10.0	10.0				6.9					6.7									
14.0	11.5	11.5	11.4			10.0	10.0				6.9					6.7						5.6			
16.0	11.2	11.0	10.6	10.4	10.4	10.0	9.9	9.7			6.9					6.7						5.6			
18.0		9.3	9.9	9.7	9.7	9.2	9.5	9.1	8.9		6.9	6.9				6.7	6.7					5.6			
20.0			7.6	8.3	8.7	7.7	8.6	8.4	8.4		6.9	6.9	6.9			6.7	6.7					5.6	5.6		
22.0							6.7	7.6	8.0			6.7	6.9	6.9			6.7	6.3				5.6	5.6		
24.0									6.2				6.3	6.9	6.4			6.1	5.6			5.6	5.0		
26.0													5.6	6.2				5.6	5.5	5.1			4.8		
28.0																		5.3	5.0				4.7	4.3	
30.0																			4.5				4.2	3.9	
32.0																								3.8	
θ(°)	75~84	74~84	74~84	75~84	75~84	74~84	74~84	74~84	75~84	74~84	73~84	74~84	74~84	74~84	76~84	74~84	75~84	74~84	75~84	74~84	74~84	75~84	75~84	76~84	
標準フック											7.8t														
フック質量											450kg										300kg				
標準巻掛本数											2										1				

注)カウンタウエイト 12t、アウトリガ張出幅 8.3m

●FE性能 59.2mブーム+1.85m+フルオートラフィングジブ

(単位:t)

ジブ長さ 作業半径 (m)	8.5m オフセット					11.6m オフセット					14.7m オフセット					17.8m オフセット					20.9m オフセット				
	5°	15°	30°	45°	60°	5°	15°	30°	45°	60°	5°	15°	30°	45°	60°	5°	15°	30°	45°	60°	5°	15°	30°	45°	60°
11.0	9.6					7.5																			
12.0	9.6	9.4				7.5	7.5				6.5					5.7									
14.0	9.0	8.7	8.3			7.5	7.4				6.5	6.5				5.7						5.0			
16.0	8.4	8.3	7.7	7.5		7.5	7.4				6.5	6.3				5.7	5.7					5.0			
18.0		7.8	7.3	7.1	7.0	7.2	6.9	6.5			6.5	6.3				5.7	5.5					5.0	5.0		
20.0			6.9	6.7	6.6		6.5				6.3	6.0	5.5			5.7	5.5					5.0	5.0		
22.0							5.8	5.6	5.5			5.6	5.2	5.0			5.2	4.8				5.0	4.8		
24.0								5.3	5.3				5.0	4.8	4.7			4.6				4.5	4.2		
26.0													4.6	4.5				4.4	4.2				4.0		
28.0																		4.0	3.9				3.8	3.6	
30.0																			3.8					3.5	
32.0																								3.3	
θ(°)	76~84	75~84	75~84	76~84	76~84	75~84	75~84	75~84	75~84	76~84	74~84	75~84	75~84	75~84	77~84	75~84	76~84	75~84	76~84	75~84	74~84	75~84	76~84	77~84	
標準フック											7.8t														
フック質量											450kg										300kg				
標準巻掛本数											2										1				

注)カウンタウエイト 12t、アウトリガ張出幅 8.3m

TADANO ATF220G-5

■定格総荷重表

●FE性能 63.4mブーム+1.85m+フルオートラフィングジブ

(単位: t)

ジブ長さ 作業半径 (m)	8.5m オフセット					11.6m オフセット					14.7m オフセット					17.8m オフセット					20.9m オフセット				
	5°	15°	30°	45°	60°	5°	15°	30°	45°	60°	5°	15°	30°	45°	60°	5°	15°	30°	45°	60°	5°	15°	30°	45°	60°
14.0	7.0	7.0				6.1					5.4					4.7									
16.0	6.8	6.6	6.3			6.1	6.0				5.4					4.7									
18.0	6.3	6.1	5.9	5.7		5.9	5.7	5.3			5.4	5.2				4.7					4.2				
20.0			5.5	5.3	5.3		5.3	5.0	4.8		5.2	4.9				4.7	4.5				4.2				
22.0					5.0			4.7	4.5	4.5		4.6	4.3			4.3					4.0				
24.0									4.3	4.2			4.1	3.9			3.8				3.7				
26.0													3.7	3.7			3.6						3.3		
28.0																			3.3	3.2			3.1		
30.0																			3.1					2.9	
32.0																								2.7	
θ(°)	75~84	76~84	76~84	77~84	76~84	76~84	76~84	76~84	76~84	77~84	75~84	75~84	76~84	76~84	77~84	76~84	76~84	76~84	77~84	76~84	77~84	76~84	76~84	77~84	
標準フック												7.8t													
フック質量												300kg													
標準巻掛本数												1													

注)カウンタウエイト 12t、アウトリガ張出幅 8.3m

●FG性能 55.0mブーム+1.85m+フルオートラフィングジブ

(単位: t)

ジブ長さ 作業半径 (m)	8.5m オフセット					11.6m オフセット					14.7m オフセット					17.8m オフセット					20.9m オフセット				
	5°	15°	30°	45°	60°	5°	15°	30°	45°	60°	5°	15°	30°	45°	60°	5°	15°	30°	45°	60°	5°	15°	30°	45°	60°
11.0	11.5					10.0					6.9					6.7									
12.0	11.5	11.5				10.0	10.0				6.9					6.7									
14.0	11.5	11.5	11.4			10.0	9.9	9.7			6.9					6.7					5.6				
16.0	11.2	11.0	10.6	10.4	10.4	10.0	9.9	9.7			6.9	6.9				6.7	6.7				5.6				
18.0	10.5	10.2	9.9	9.7	9.7	9.6	9.5	9.1	8.9		6.9	6.9				6.7	6.7				5.6	5.6			
20.0	9.8	9.6	9.3	9.1	9.1	9.3	8.9	8.6	8.4	8.4	6.9	6.9	6.9			6.7	6.7				5.6	5.6			
22.0	9.2	9.0	8.7	8.6	8.6	8.7	8.4	8.1	8.0	8.0	6.9	6.9	6.9	6.9		6.7	6.7	6.3			5.6	5.6			
24.0	8.5	8.4	8.2	8.1	8.1	8.1	7.9	7.6	7.5	7.5	6.9	6.9	6.9	6.9	6.4	6.7	6.7	6.1	5.6		5.6	5.6	5.0		
26.0	7.9	7.8	7.7	7.6	7.6	7.6	7.4	7.2	7.1	7.1	6.9	6.9	6.7	6.6	6.3	6.6	6.5	5.9	5.5	5.1	5.6	5.6	4.8		
28.0	7.3	7.3	7.2	7.2		7.1	7.0	6.8	6.7	6.7	6.7	6.5	6.3	6.2	6.2	6.4	6.2	5.8	5.4	5.0	5.6	5.4	4.7	4.3	
30.0	6.8	6.8	6.7	6.7		6.6	6.6	6.4	6.4		6.3	6.2	6.0	5.9	5.9	6.0	5.9	5.6	5.2	4.9	5.5	5.2	4.6	4.2	3.9
32.0	6.3	6.3	6.3	6.3		6.2	6.2	6.1	6.1		6.0	5.8	5.7	5.6	5.6	5.7	5.5	5.4	5.1	4.9	5.3	5.0	4.4	4.1	3.8
34.0	5.9	5.9	5.9	5.9		5.8	5.8	5.8	5.7		5.6	5.5	5.4	5.3		5.4	5.3	5.1	5.0	4.9	5.2	4.9	4.3	4.0	3.8
36.0	5.5	5.5	5.5	5.5		5.4	5.4	5.4	5.4		5.2	5.2	5.1	5.1		5.1	5.0	4.9	4.8		4.9	4.7	4.2	4.0	3.7
38.0	4.9	5.1	5.1	5.1		5.1	5.0	5.0	5.1		4.9	4.9	4.9	4.8		4.8	4.8	4.6	4.6		4.7	4.5	4.1	3.9	3.7
40.0	3.9	4.1	4.4			4.5	4.7	4.7	4.7		4.6	4.6	4.6	4.6		4.5	4.5	4.4	4.4		4.4	4.3	4.0	3.8	
42.0	3.0	3.2	3.5			3.6	4.0	4.4			4.3	4.3	4.3	4.3		4.2	4.2	4.2	4.2		4.2	4.1	3.9	3.7	
44.0	2.2	2.4	2.6			2.8	3.1	3.5			3.6	4.0	4.0	4.1		4.0	4.0	4.0	4.0		3.9	3.9	3.8	3.7	
46.0	1.4	1.6	1.8			2.1	2.4	2.7			2.8	3.2	3.7			3.4	3.7	3.8	3.8		3.7	3.7	3.7	3.6	
48.0			1.1			1.4	1.7	1.9			2.2	2.5	2.9			2.7	3.1	3.5			3.2	3.5	3.5	3.5	
50.0							1.0	1.2			1.5	1.9	2.2			2.0	2.4	2.9			2.6	3.1	3.3	3.4	
55.0																	1.0	1.3			1.2	1.6	2.0		
θ(°)	43~84	44~84	40~84	55~84	69~84	44~84	42~84	44~84	55~84	69~84	45~84	46~84	40~84	55~84	69~84	47~84	43~84	40~84	55~84	69~84	44~84	46~84	49~84	55~84	69~84
標準フック												25t													
フック質量												450kg													
標準巻掛本数												2													

注)カウンタウエイト 71t、アウトリガ張出幅 7.0m

●FG性能 59.2mブーム+1.85m+フルオートラフィングジブ

(単位: t)

ジブ長さ 作業半径 (m)	8.5m オフセット					11.6m オフセット					14.7m オフセット					17.8m オフセット					20.9m オフセット				
	5°	15°	30°	45°	60°	5°	15°	30°	45°	60°	5°	15°	30°	45°	60°	5°	15°	30°	45°	60°	5°	15°	30°	45°	60°
11.0	9.6					7.5																			
12.0	9.6	9.4				7.5	7.5				6.5					5.7									
14.0	9.0	8.7	8.3			7.5	7.4				6.5	6.5				5.7					5.0				
16.0	8.4	8.3	7.7	7.5		7.5	7.4				6.5	6.3				5.7	5.7				5.0				
18.0	8.1	7.8	7.3	7.1	7.0	7.2	6.9	6.5			6.3	6.0	5.5			5.7	5.5				5.0	5.0			
20.0	7.5	7.3	6.9	6.7	6.6	7.0	6.5	6.1	5.9		6.3	6.0	5.5	5.0		5.7	5.5	4.8			5.0	4.8			
22.0	7.1	6.8	6.6	6.3	6.3	6.5	6.2	5.8	5.6	5.5	5.9	5.6	5.2	5.0		5.5	5.2	4.8			5.0	4.8			
24.0	6.6	6.4	6.2	6.0	6.0	6.1	5.9	5.5	5.3	5.3	5.7	5.3	5.0	4.8	4.7	5.2	4.9	4.6			4.8	4.5	4.2		
26.0	6.2	6.0	5.8	5.7	5.7	5.8	5.6	5.2	5.0	5.0	5.4	5.1	4.8	4.6	4.5	5.0	4.7	4.4	4.2		4.6	4.3	4.0		
28.0	5.9	5.7	5.5	5.4		5.4	5.2	5.0	4.8	4.8	5.1	4.8	4.5	4.4	4.3	4.8	4.4	4.2	4.0	3.9	4.3	4.1	3.8	3.6	
30.0	5.5	5.4	5.2	5.1		5.1	5.0	4.8	4.6		4.8	4.6	4.3	4.2	4.2	4.5	4.2	4.0	3.8	3.8	4.2	3.9	3.6	3.5	
32.0	5.2	5.1	4.9	4.9		4.9	4.7	4.5	4.4		4.5	4.4	4.1	4.0	4.0	4.3	4.0	3.8	3.7	3.6	4.0	3.7	3.5	3.3	3.3
34.0	4.9	4.8	4.7	4.6		4.6	4.4	4.3	4.2		4.3	4.1	3.9	3.8		4.1	3.9	3.6	3.5	3.5	3.8	3.5	3.3	3.2	3.2
36.0	4.7	4.6	4.4	4.4		4.3	4.2	4.1	4.0		4.1	3.9	3.8	3.7		3.8	3.7	3.4	3.3		3.6	3.4	3.2	3.1	3.1
38.0	4.4	4.3	4.2	4.2		4.1	4.0	3.9	3.8		3.9	3.7	3.6	3.5		3.6	3.5	3.3	3.2		3.4	3.2	3.0	3.0	3.0
40.0	4.1	4.1	4.0			3.9	3.8	3.7	3.7		3.7	3.5	3.4	3.4		3.5	3.3	3.2	3.1		3.3	3.1	2.9	2.8	
42.0	3.3	3.6	3.8			3.7	3.6	3.5	3.5		3.5	3.4	3.3	3.2		3.3	3.2	3.1	3.0		3.1	3.0	2.8	2.7	
44.0	2.5	2.7	3.0			3.3	3.4	3.4			3.3	3.2	3.1	3.1		3.1	3.0	2.9	2.9		2.9	2.8	2.7	2.6	
46.0	1.8	2.0	2.2			2.6	2.9	3.2			3.1	3.1	3.0			3.0	2.9	2.8	2.8		2.8	2.7	2.6	2.5	
48.0	1.1	1.3	1.5			1.9	2.1	2.4			2.4	2.8	2.8			2.8	2.7	2.7	2.6		2.7	2.6	2.5	2.4	
50.0						1.2	1.5	1.8			1.8	2.1	2.5			2.2	2.6	2.5			2.5	2.5	2.4	2.4	
55.0																	1.2	1.6			1.4	1.8	2.1		
θ(°)	44~84	45~84	46~84	57~84	70~84	45~84	46~84	43~84	57~84	70~84	48~84	49~84	45~84	57~84	70~84	50~84	47~84	48~84	57~84	70~84	47~84	49~84	52~84	57~84	70~84
標準フック												7.8t													
フック質量												300kg													
標準巻掛本数												1													

注)カウンタウエイト 71t、アウトリガ張出幅 7.0m

TADANO ATF220G-5

■ 定格総荷重表

● FG性能 63.4mブーム+1.85m+フルオートラフィングジブ

(単位: t)

ジブ長さ 作業半径 (m)	8.5m オフセット					11.6m オフセット					14.7m オフセット					17.8m オフセット					20.9m オフセット				
	5°	15°	30°	45°	60°	5°	15°	30°	45°	60°	5°	15°	30°	45°	60°	5°	15°	30°	45°	60°	5°	15°	30°	45°	60°
14.0	7.0	7.0				6.1					5.4					4.7									
16.0	6.8	6.6	6.3			6.1	6.0				5.4					4.7									
18.0	6.3	6.1	5.9	5.7		5.9	5.7	5.3			5.4	5.2				4.7							4.2		
20.0	6.0	5.8	5.5	5.3	5.3	5.5	5.3	5.0	4.8		5.2	4.9				4.7	4.5					4.2			
22.0	5.6	5.4	5.1	5.0	5.0	5.2	5.0	4.7	4.5	4.5	4.8	4.6	4.3			4.6	4.3					4.2	4.0		
24.0	5.3	5.1	4.8	4.7	4.7	4.9	4.7	4.4	4.3	4.2	4.5	4.3	4.1	3.9		4.3	4.0	3.8				4.0	3.7		
26.0	4.9	4.8	4.6	4.4	4.4	4.6	4.4	4.2	4.1	4.0	4.3	4.1	3.9	3.7	3.7	4.0	3.8	3.6				3.8	3.5	3.3	
28.0	4.6	4.5	4.3	4.2	4.2	4.3	4.1	3.9	3.9	3.8	4.0	3.8	3.6	3.5	3.5	3.8	3.6	3.4	3.3	3.2		3.6	3.4	3.1	
30.0	4.3	4.2	4.1	4.0		4.1	3.9	3.7	3.6	3.6	3.8	3.6	3.5	3.3	3.3	3.6	3.4	3.2	3.1	3.1	3.3	3.2	3.0	2.9	
32.0	4.0	4.0	3.9	3.8		3.8	3.7	3.5	3.4		3.6	3.4	3.3	3.2	3.2	3.4	3.2	3.0	2.9	2.9	3.2	3.0	2.8	2.7	
34.0	3.8	3.7	3.6	3.6		3.6	3.5	3.3	3.3		3.4	3.2	3.1	3.0	3.0	3.2	3.0	2.9	2.8	2.8	3.0	2.9	2.7	2.6	
36.0	3.6	3.5	3.4	3.4		3.4	3.3	3.2	3.1		3.2	3.1	2.9	2.8		3.0	2.9	2.7	2.7	2.6	2.8	2.7	2.6	2.5	
38.0	3.3	3.3	3.2	3.2		3.2	3.1	3.0	2.9		3.0	2.9	2.8	2.7		2.9	2.7	2.6	2.5		2.7	2.5	2.4	2.3	
40.0	3.1	3.1	3.0	3.0		3.0	2.9	2.8	2.8		2.8	2.8	2.6	2.6		2.7	2.6	2.4	2.4		2.5	2.4	2.3	2.2	
42.0	3.0	2.9	2.8			2.8	2.7	2.7	2.6		2.7	2.6	2.5	2.4		2.5	2.4	2.3	2.3		2.4	2.3	2.2	2.1	
44.0	2.8	2.7	2.7			2.6	2.6	2.5	2.5		2.5	2.4	2.4	2.3		2.4	2.3	2.2	2.1		2.3	2.2	2.0	2.0	
46.0	2.3	2.5	2.5			2.5	2.4	2.4			2.4	2.3	2.3	2.2		2.3	2.2	2.1	2.0		2.2	2.1	1.9	1.9	
48.0	1.6	1.8	2.0			2.1	2.3	2.2			2.2	2.2	2.1			2.1	2.1	2.0	2.0		2.0	2.0	1.8	1.8	
50.0	1.0	1.1	1.3			1.5	1.8	2.1			2.0	2.0	2.0			2.0	1.9	1.9	1.9		1.9	1.9	1.8	1.7	
55.0													1.2			1.1	1.4	1.6				1.5	1.6	1.6	
60.0																								1.2	
θ(°)	46~84	47~84	47~84	57~84	70~84	48~84	49~84	51~84	57~84	70~84	50~84	52~84	48~84	57~84	70~84	48~84	49~84	51~84	57~84	70~84	50~84	52~84	49~84	57~84	70~84
標準フック												7.8t													
フック質量												300kg													
標準巻掛本数												1													

注) カウンタウエイト 71t、アウトリガ張出幅 7.0m

● FH性能 55.0mブーム+1.85m+フルオートラフィングジブ

(単位: t)

ジブ長さ 作業半径 (m)	8.5m オフセット					11.6m オフセット					14.7m オフセット					17.8m オフセット					20.9m オフセット				
	5°	15°	30°	45°	60°	5°	15°	30°	45°	60°	5°	15°	30°	45°	60°	5°	15°	30°	45°	60°	5°	15°	30°	45°	60°
11.0	11.5					10.0					6.9					6.7									
12.0	11.5	11.5				10.0	10.0				6.9					6.7									
14.0	11.5	11.5	11.4			10.0	10.0				6.9					6.7									
16.0	11.2	11.0	10.6	10.4	10.4	10.0	9.9	9.7			6.9					6.7								5.6	
18.0	10.5	10.2	9.9	9.7	9.7	9.6	9.5	9.1	8.9		6.9	6.9				6.7	6.7							5.6	
20.0	9.8	9.6	9.3	9.1	9.1	9.3	8.9	8.6	8.4	8.4	6.9	6.9	6.9			6.7	6.7							5.6	
22.0	9.2	9.0	8.7	8.6	8.6	8.7	8.4	8.1	8.0	8.0	6.9	6.9	6.9	6.9		6.7	6.7	6.3						5.6	
24.0	8.5	8.4	8.2	8.1	8.1	8.1	7.9	7.6	7.5	7.5	6.9	6.9	6.9	6.9	6.4	6.7	6.7	6.1	5.6					5.6	
26.0	7.9	7.8	7.7	7.6	7.6	7.6	7.4	7.2	7.1	7.1	6.9	6.9	6.7	6.6	6.3	6.6	6.5	5.9	5.5	5.1				5.6	
28.0	6.3	6.8	7.2	7.2		7.1	7.0	6.8	6.7	6.7	6.7	6.5	6.3	6.2	6.2	6.4	6.2	5.8	5.4	5.0				5.4	
30.0	4.8	5.3	5.9	6.2		5.6	6.2	6.4	6.4		6.3	6.2	6.0	5.9	5.9	6.0	5.9	5.6	5.2	4.9				5.2	
32.0	3.6	4.0	4.5	4.8		4.3	4.8	5.6	6.1		5.2	5.8	5.7	5.6	5.6	5.7	5.5	5.4	5.1	4.9				5.3	
34.0		2.8	3.3	3.5		3.1	3.7	4.3	4.7		4.0	4.7	5.4	5.3		4.6	5.3	5.1	5.0	4.9				5.1	
36.0				2.4			2.6	3.2	3.6		3.0	3.6	4.4	4.9		3.5	4.3	4.9	4.8					4.1	
38.0									2.5		2.1	2.7	3.4	3.8		2.6	3.3	4.2	4.6					3.2	
40.0													2.5	2.9			2.5	3.3	3.8					2.4	
42.0														2.0				2.4	2.9					2.4	
44.0																			2.1					2.5	
46.0																								1.7	
θ(°)	59~84	58~84	59~84	58~84	69~84	59~84	59~84	60~84	59~84	69~84	57~84	59~84	59~84	58~84	69~84	59~84	59~84	60~84	59~84	69~84	59~84	59~84	59~84	60~84	
標準フック												7.8t													
フック質量												450kg													
標準巻掛本数												2													

注) カウンタウエイト 47t、アウトリガ張出幅 7.0m

● FH性能 59.2mブーム+1.85m+フルオートラフィングジブ

(単位: t)

ジブ長さ 作業半径 (m)	8.5m オフセット					11.6m オフセット					14.7m オフセット					17.8m オフセット					20.9m オフセット				
	5°	15°	30°	45°	60°	5°	15°	30°	45°	60°	5°	15°	30°	45°	60°	5°	15°	30°	45°	60°	5°	15°	30°	45°	60°
11.0	9.6					7.5					6.5					5.7									
12.0	9.6	9.4				7.5	7.5				6.5					5.7									
14.0	9.0	8.7	8.3			7.5	7.5				6.5					5.7									
16.0	8.4	8.3	7.7	7.5		7.5	7.4				6.5	6.5				5.7								5.0	
18.0	8.1	7.8	7.3	7.1	7.0	7.2	6.9	6.5			6.5	6.3				5.7	5.7							5.0	
20.0	7.5	7.3	6.9	6.7	6.6	7.0	6.5	6.1	5.9		6.3	6.0	5.5			5.7	5.5							5.0	
22.0	7.1	6.8	6.6	6.3	6.3	6.5	6.2	5.8	5.6	5.5	5.9	5.6	5.2	5.0		5.5	5.2	4.8						5.0	
24.0	6.6	6.4	6.2	6.0	6.0	6.1	5.9	5.5	5.3	5.3	5.7	5.3	5.0	4.8	4.7	5.2	4.9	4.6						4.8	
26.0	6.2	6.0	5.8	5.7	5.7	5.8	5.6	5.2	5.0	5.0	5.4	5.1	4.8	4.6	4.5	5.0	4.7	4.4	4.2					4.6	
28.0	5.9	5.7	5.5	5.4		5.4	5.2	5.0	4.8	4.8	5.1	4.8	4.5	4.4	4.3	4.8	4.4	4.2	4.0	3.9				4.3	
30.0	5.2	5.4	5.2	5.1		5.1	5.0	4.8	4.6		4.8	4.6	4.3	4.2	4.2	4.5	4.2	4.0	3.8	3.8				4.2	
32.0	3.9	4.3	4.8	4.9		4.8	4.7	4.5	4.4		4.5	4.4	4.1	4.0	4.0	4.3	4.0	3.8	3.7	3.6				4.0	
34.0	2.8	3.2	3.6	3.9		3.7	4.2	4.3	4.2		4.3	4.1	3.9	3.8		4.1	3.9	3.6	3.5	3.5				3.8	
36.0				2.8		2.7	3.2	3.8	4.0		3.3	3.9	3.8	3.7		3.8	3.7	3.4	3.3					3.6	
38.0								2.8	3.1		2.4	2.9	3.6	3.5		2.9	3.5	3.3	3.2					3.4	
40.0									2.2				2.7	3.2			2.7	3.2	3.1					2.6	
42.0														2.3				2.6	3.0					2.5	
44.0																			2.3					2.7	
46.0																								2.0	
θ(°)	59~84	60~84	62~84	60~84	70~84	59~84	61~84	61~84	59~84	70~84	59~84	61~84	61~84	60~84	70~84	61~84	62~84	61~84	70~84	61~84	61~84	61~84	61~84</		

TADANO ATF220G-5

■定格総荷重表

●FH性能 63.4mブーム+1.85m+フルオートラフィングジブ

(単位:t)

ジブ長さ 作業半径 (m)	8.5m オフセット					11.6m オフセット					14.7m オフセット					17.8m オフセット					20.9m オフセット				
	5°	15°	30°	45°	60°	5°	15°	30°	45°	60°	5°	15°	30°	45°	60°	5°	15°	30°	45°	60°	5°	15°	30°	45°	60°
14.0	7.0	7.0				6.1					5.4					4.7									
16.0	6.8	6.6	6.3			6.1	6.0				5.4					4.7									
18.0	6.3	6.1	5.9	5.7		5.9	5.7	5.3			5.4	5.2				4.7							4.2		
20.0	6.0	5.8	5.5	5.3	5.3	5.5	5.3	5.0	4.8		5.2	4.9				4.7	4.5					4.2			
22.0	5.6	5.4	5.1	5.0	5.0	5.2	5.0	4.7	4.5	4.5	4.8	4.6	4.3			4.6	4.3					4.2	4.0		
24.0	5.3	5.1	4.8	4.7	4.7	4.9	4.7	4.4	4.3	4.2	4.5	4.3	4.1	3.9		4.3	4.0	3.8				4.0	3.7		
26.0	4.9	4.8	4.6	4.4	4.4	4.6	4.4	4.2	4.1	4.0	4.3	4.1	3.9	3.7	3.7	4.0	3.8	3.6				3.8	3.5	3.3	
28.0	4.6	4.5	4.3	4.2	4.2	4.3	4.1	3.9	3.9	3.8	4.0	3.8	3.6	3.5	3.5	3.8	3.6	3.4	3.3	3.2		3.6	3.4	3.1	
30.0	4.3	4.2	4.1	4.0		4.1	3.9	3.7	3.6	3.6	3.8	3.6	3.5	3.3	3.3	3.6	3.4	3.2	3.1	3.1		3.3	3.2	2.9	
32.0	4.0	4.0	3.9	3.8		3.8	3.7	3.5	3.4		3.6	3.4	3.3	3.2	3.2	3.4	3.2	3.0	2.9	2.9		3.2	3.0	2.7	
34.0	3.3	3.7	3.6	3.6		3.6	3.5	3.3	3.3		3.4	3.2	3.1	3.0	3.0	3.2	3.0	2.9	2.8	2.8		3.0	2.9	2.6	
36.0		2.7	3.1	3.4		2.9	3.3	3.2	3.1		3.2	3.1	2.9	2.8		3.0	2.9	2.7	2.7	2.6		2.8	2.7	2.4	
38.0						2.5	3.0	2.9			2.6	2.9	2.8	2.7		2.9	2.7	2.6	2.5			2.7	2.5	2.3	
40.0								2.5					2.6	2.6			2.6	2.4	2.4			2.5	2.4	2.2	
42.0													2.4					2.3	2.3				2.3	2.2	
44.0																							2.2	2.0	
46.0																							1.9	1.9	
θ(°)	62~84	61~84	62~84	63~84	70~84	61~84	61~84	62~84	62~84	70~84	61~84	63~84	63~84	62~84	70~84	62~84	63~84	63~84	63~84	70~84	62~84	63~84	62~84	64~84	
標準フック	7.8t																								
フック質量	300kg																								
標準巻掛本数	1																								

注)カウンタウエイト 47t、アウトリガ張出幅 7.0m

●FI性能 55.0mブーム+1.85m+フルオートラフィングジブ

(単位:t)

ジブ長さ 作業半径 (m)	8.5m オフセット					11.6m オフセット					14.7m オフセット					17.8m オフセット					20.9m オフセット				
	5°	15°	30°	45°	60°	5°	15°	30°	45°	60°	5°	15°	30°	45°	60°	5°	15°	30°	45°	60°	5°	15°	30°	45°	60°
11.0	11.5																								
12.0	11.5	11.5				10.0																			
14.0	11.5	11.5	11.4			10.0	10.0				6.9					6.7									
16.0	11.2	11.0	10.6	10.4	10.4	10.0	9.9	9.7			6.9					6.7						5.6			
18.0	10.5	10.2	9.9	9.7	9.7	9.6	9.5	9.1	8.9		6.9	6.9				6.7	6.7				5.6				
20.0	9.8	9.6	9.3	9.1	9.1	9.3	8.9	8.6	8.4	8.4	6.9	6.9	6.9			6.7	6.7				5.6	5.6			
22.0	8.8	9.0	8.7	8.6	8.6	8.7	8.4	8.1	8.0	8.0	6.9	6.9	6.9	6.9		6.7	6.7	6.3			5.6	5.6			
24.0	6.6	7.3	8.1	8.1	8.1	7.4	7.9	7.6	7.5	7.5	6.9	6.9	6.9	6.9	6.4	6.7	6.7	6.1	5.6		5.6	5.6	5.0		
26.0	4.8	5.4	6.1	6.6	6.9	5.6	6.4	7.2	7.1	7.1	6.6	6.9	6.7	6.6	6.3	6.6	6.5	5.9	5.5	5.1	5.6	5.6	4.8		
28.0		3.9	4.5	4.9		4.1	4.8	5.7	6.4	6.7	5.0	5.9	6.3	6.2	6.2	5.6	6.2	5.8	5.4	5.0	5.6	5.4	4.7	4.3	
30.0								4.3	4.8		3.7	4.5	5.6	5.9	5.9	4.3	5.3	5.6	5.2	4.9	4.9	5.2	4.6	4.2	
32.0									3.5			3.3	4.3	5.0	5.4		4.0	5.2	5.1	4.9	3.7	4.8	4.4	3.8	
34.0													3.2	3.8				4.0	4.8	4.9	3.7	4.3	4.0	3.8	
36.0																	3.0	3.7				3.9	4.0	3.7	
38.0																		2.7				2.9	3.7	3.7	
40.0																								2.8	
θ(°)	65~84	64~84	66~84	67~84	69~84	65~84	66~84	66~84	66~84	69~84	65~84	65~84	65~84	67~84	69~84	66~84	66~84	65~84	65~84	69~84	66~84	66~84	66~84	69~84	
標準フック	7.8t																								
フック質量	450kg																								
標準巻掛本数	2																								

注)カウンタウエイト 35t、アウトリガ張出幅 7.0m

●FI性能 59.2mブーム+1.85m+フルオートラフィングジブ

(単位:t)

ジブ長さ 作業半径 (m)	8.5m オフセット					11.6m オフセット					14.7m オフセット					17.8m オフセット					20.9m オフセット				
	5°	15°	30°	45°	60°	5°	15°	30°	45°	60°	5°	15°	30°	45°	60°	5°	15°	30°	45°	60°	5°	15°	30°	45°	60°
11.0	9.6																								
12.0	9.6	9.4				7.5																			
14.0	9.0	8.7	8.3			7.5	7.5				6.5					5.7									
16.0	8.4	8.3	7.7	7.5		7.5	7.4				6.5	6.5				5.7					5.0				
18.0	8.1	7.8	7.3	7.1	7.0	7.2	6.9	6.5			6.5	6.3				5.7	5.7				5.0				
20.0	7.5	7.3	6.9	6.7	6.6	7.0	6.5	6.1	5.9		6.3	6.0	5.5			5.7	5.5				5.0	5.0			
22.0	7.1	6.8	6.6	6.3	6.3	6.5	6.2	5.8	5.6	5.5	5.9	5.6	5.2	5.0		5.5	5.2	4.8			5.0	4.8			
24.0	6.6	6.4	6.2	6.0	6.0	6.1	5.9	5.5	5.3	5.3	5.7	5.3	5.0	4.8	4.7	5.2	4.9	4.6			4.8	4.5	4.2		
26.0	5.2	5.8	5.8	5.7	5.7	5.8	5.6	5.2	5.0	5.0	5.4	5.1	4.8	4.6	4.5	5.0	4.7	4.4	4.2		4.6	4.3	4.0		
28.0		4.2	4.9	5.3		4.7	5.2	5.0	4.8	4.8	5.1	4.8	4.5	4.3	4.3	4.8	4.4	4.2	4.0	3.9	4.3	4.1	3.8		
30.0				3.8			4.0	4.8	4.6		4.0	4.6	4.3	4.2	4.2	4.5	4.2	4.0	3.8	3.8	4.2	3.9	3.6		
32.0								3.6	4.1			3.6	4.1	4.0	4.0		4.0	3.8	3.7	3.6	3.9	3.7	3.5		
34.0													3.4	3.8				3.6	3.5	3.5		3.5	3.3		
36.0																	3.2	3.3				3.2	3.1		
38.0																		2.9				3.0	3.0		
40.0																								2.8	
θ(°)	67~84	66~84	67~84	66~84	70~84	67~84	66~84	66~84	67~84	70~84	66~84	66~84	67~84	68~84	70~84	67~84	68~84	67~84	67~84	70~84	67~84	68~84	67~84	68~84	
標準フック	25t																								
フック質量	450kg																								
標準巻掛本数	2																								

注)カウンタウエイト 35t、アウトリガ張出幅 7.0m

TADANO ATF220G-5

■ 定格総荷重表

● FI性能 63.4mブーム+1.85m+フルオートラフィングジブ

(単位:t)

ジブ長さ 作業半径 (m)	8.5m					11.6m					14.7m					17.8m					20.9m					
	オフセット					オフセット					オフセット					オフセット					オフセット					
	5°	15°	30°	45°	60°	5°	15°	30°	45°	60°	5°	15°	30°	45°	60°	5°	15°	30°	45°	60°	5°	15°	30°	45°	60°	
14.0	7.0	7.0				6.1					5.4															
16.0	6.8	6.6	6.3			6.1	6.0				5.4						4.7									
18.0	6.3	6.1	5.9	5.7		5.9	5.7	5.3			5.4	5.2				4.7							4.2			
20.0	6.0	5.8	5.5	5.3	5.3	5.5	5.3	5.0	4.8		5.2	4.9	4.3			4.7	4.5					4.2				
22.0	5.6	5.4	5.1	5.0	5.0	5.2	5.0	4.7	4.5	4.5	4.8	4.6	4.1	3.9		4.6	4.3					4.2	4.0			
24.0	5.3	5.1	4.8	4.7	4.7	4.9	4.7	4.4	4.3	4.2	4.5	4.3	3.9	3.7	3.7	4.3	4.0	3.8				4.0	3.7			
26.0	4.9	4.8	4.6	4.4	4.4	4.6	4.4	4.2	4.1	4.0	4.3	4.1	3.6	3.5	3.5	4.0	3.8	3.6				3.8	3.5	3.3		
28.0	4.3	4.5	4.3	4.2	4.2	4.3	4.1	3.9	3.9	3.8	4.0	3.8	3.5	3.3	3.3	3.8	3.6	3.4	3.3	3.2		3.6	3.4	3.1		
30.0			4.0	4.0			3.9	3.7	3.6	3.6	3.8	3.6	3.3	3.2	3.2	3.6	3.4	3.2	3.1	3.1		3.3	3.2	3.0	2.9	
32.0								3.5	3.4			3.4	3.1	3.0	3.0		3.2	3.0	2.9	2.9		3.2	3.0	2.8	2.7	2.7
34.0														2.8									2.9	2.7	2.6	2.6
36.0																	2.9	2.8	2.8				2.9	2.7	2.6	2.6
38.0																		2.7	2.7	2.6				2.6	2.5	2.4
40.0																			2.5				2.4	2.3	2.3	
θ(°)	67~84	68~84	67~84	68~84	70~84	68~84	68~84	68~84	69~84	70~84	68~84	68~84	68~84	70~84	69~84	69~84	68~84	68~84	70~84	68~84	68~84	69~84	69~84	69~84	70~84	
標準フック	7.8t																									
フック質量	300kg																									
標準巻掛本数	1																									

注) カウンタウエイト 35t、アウトリガ張出幅 7.0m

● FJ性能 55.0mブーム+1.85m+フルオートラフィングジブ

(単位:t)

ジブ長さ 作業半径 (m)	8.5m					11.6m					14.7m					17.8m					20.9m				
	オフセット					オフセット					オフセット					オフセット					オフセット				
	5°	15°	30°	45°	60°	5°	15°	30°	45°	60°	5°	15°	30°	45°	60°	5°	15°	30°	45°	60°	5°	15°	30°	45°	60°
11.0	11.5																								
12.0	11.5	11.5				10.0																			
14.0	11.5	11.5	11.4			10.0	10.0				6.9					6.7									
16.0	11.2	11.0	10.6	10.4	10.4	10.0	9.9	9.7			6.9					6.7						5.6			
18.0	9.9	10.2	9.9	9.7	9.7	9.6	9.5	9.1	8.9		6.9	6.9				6.7	6.7				5.6				
20.0	7.1	8.0	9.0	9.1	9.1	8.0	8.9	8.6	8.4	8.4	6.9	6.9	6.9			6.7	6.7				5.6	5.6			
22.0			6.6	7.3	7.7		6.7	8.0	8.0	8.0	6.8	6.9	6.9	6.9		6.7	6.7	6.3			5.6	5.6			
24.0					5.5			6.0	6.8	7.3		6.0	6.9	6.9	6.4	5.5	6.7	6.1	5.6		5.6	5.6	5.0		
26.0									5.0	5.4			5.7	6.6	6.3		5.2	5.9	5.5	5.1		5.6	4.8		
28.0													5.1	5.7			5.2	5.4	5.0		4.5	4.7	4.3		
30.0														4.2			4.9	4.9			4.6	4.2	3.9		
32.0																			4.1			4.1	3.8		
34.0																						3.6	3.8		
θ(°)	71~84	72~84	72~84	73~84	71~84	72~84	72~84	72~84	72~84	72~84	72~84	72~84	73~84	73~84	72~84	71~84	71~84	73~84	73~84	72~84	72~84	71~84	73~84	72~84	74~84
標準フック	25t																								
フック質量	450kg																								
標準巻掛本数	2																								

注) カウンタウエイト 23.5t、アウトリガ張出幅 7.0m

● FJ性能 59.2mブーム+1.85m+フルオートラフィングジブ

(単位:t)

ジブ長さ 作業半径 (m)	8.5m					11.6m					14.7m					17.8m					20.9m				
	オフセット					オフセット					オフセット					オフセット					オフセット				
	5°	15°	30°	45°	60°	5°	15°	30°	45°	60°	5°	15°	30°	45°	60°	5°	15°	30°	45°	60°	5°	15°	30°	45°	60°
11.0	9.6																								
12.0	9.6	9.4				7.5																			
14.0	9.0	8.7	8.3			7.5	7.5				6.5					5.7									
16.0	8.4	8.3	7.7	7.5		7.5	7.4				6.5	6.5				5.7					5.0				
18.0	8.1	7.8	7.3	7.1	7.0	7.2	6.9	6.5			6.5	6.3				5.7	5.7				5.0				
20.0	7.5	7.3	6.9	6.7	6.6	7.0	6.5	6.1	5.9		6.3	6.0	5.5			5.7	5.5				5.0	5.0			
22.0			6.6	6.3	6.3	6.4	6.2	5.8	5.6	5.5	5.9	5.6	5.2	5.0		5.5	5.2	4.8			5.0	4.8			
24.0					5.8			5.5	5.3	5.3		5.3	5.0	4.8	4.7	5.2	4.9	4.6			4.8	4.5	4.2		
26.0								5.0	5.0			4.8	4.6	4.5		4.7	4.4	4.2			4.3	4.0			
28.0												4.4	4.3			4.2	4.0	3.9			3.8	3.6			
30.0												4.2				3.8	3.8				3.6	3.5			
32.0																3.6						3.3	3.3		
34.0																						3.2	3.2		
θ(°)	72~84	73~84	73~84	74~84	73~84	72~84	73~84	73~84	73~84	74~84	73~84	73~84	74~84	74~84	73~84	72~84	73~84	74~84	74~84	74~84	73~84	74~84	74~84	73~84	75~84
標準フック	25t																								
フック質量	450kg																								
標準巻掛本数	2																								

注) カウンタウエイト 23.5t、アウトリガ張出幅 7.0m

TADANO ATF220G-5

■ 定格総荷重表

● FJ性能 63.4mブーム+1.85m+フルオートラフィングジブ

(単位:t)

ジブ長さ 作業半径 (m)	8.5m					11.6m					14.7m					17.8m					20.9m					
	オフセット					オフセット					オフセット					オフセット					オフセット					
	5°	15°	30°	45°	60°	5°	15°	30°	45°	60°	5°	15°	30°	45°	60°	5°	15°	30°	45°	60°	5°	15°	30°	45°	60°	
14.0	7.0	7.0				6.1					5.4															
16.0	6.8	6.6	6.3			6.1	6.0				5.4										4.7					
18.0	6.3	6.1	5.9	5.7		5.9	5.7	5.3			5.4	5.2								4.7				4.2		
20.0	6.0	5.8	5.5	5.3	5.3	5.5	5.3	5.0	4.8		5.2	4.9								4.7	4.5			4.2		
22.0		5.4	5.1	5.0	5.0	5.2	5.0	4.7	4.5	4.5	4.8	4.6	4.3							4.6	4.3			4.2	4.0	
24.0				4.7	4.7						4.4	4.3	4.2							4.3	4.0	3.8		4.0	3.7	
26.0											4.1	4.0								3.9	3.7	3.7		3.8	3.6	
28.0																				3.5	3.5			3.4	3.3	3.2
30.0																						3.3		3.1	3.1	3.1
32.0																								2.9	2.9	2.9
34.0																								2.9	2.7	2.7
36.0																									2.7	2.6
θ(°)	73~84	73~84	74~84	73~84	74~84	73~84	74~84	74~84	74~84	75~84	74~84	74~84	75~84	75~84	74~84	73~84	73~84	75~84	75~84	75~84	74~84	75~84	75~84	76~84	76~84	
標準フック	7.8t																									
フック質量	300kg																									
標準巻掛本数	1																									

注) カウンタウエイト 23.5t、アウトリガ張出幅 7.0m

● FL性能 55.0mブーム+1.85m+フルオートラフィングジブ

(単位:t)

ジブ長さ 作業半径 (m)	8.5m					11.6m					14.7m					17.8m					20.9m				
	オフセット					オフセット					オフセット					オフセット					オフセット				
	5°	15°	30°	45°	60°	5°	15°	30°	45°	60°	5°	15°	30°	45°	60°	5°	15°	30°	45°	60°	5°	15°	30°	45°	60°
11.0	11.5																								
12.0	11.5	11.5				10.0																			
14.0	11.5	11.5	11.4			10.0	10.0				6.9					6.7									
16.0	11.2	11.0	10.6	10.4	10.4	10.0	9.9	9.7			6.9					6.7								5.6	
18.0	10.3	10.2	9.9	9.7	9.7	9.6	9.5	9.1	8.9		6.9	6.9				6.7	6.7							5.6	
20.0	7.5	8.3	9.3	9.1	9.1	8.3	8.9	8.6	8.4	8.4	6.9	6.9	6.9			6.7	6.7						5.6	5.6	
22.0		6.0	7.0	7.6	8.0	6.1	7.1	8.1	8.0	8.0	6.9	6.9	6.9	6.9		6.7	6.7	6.3					5.6	5.6	
24.0				5.6	5.8		5.2	6.3	7.2	7.5	5.3	6.4	6.9	6.4	5.9	6.7	6.1	5.6					5.6	5.6	5.0
26.0									5.3	5.8		4.8	6.0	6.6	6.3	5.5	5.9	5.5	5.1				5.0	5.6	4.8
28.0												4.5	5.4	6.0			5.5	5.4	5.0				4.9	4.7	4.3
30.0													4.0	4.5			4.2	5.1	4.9				4.6	4.2	3.9
32.0																	3.9	4.4					4.0	4.1	3.8
34.0																								3.9	3.8
36.0																									3.4
θ(°)	71~84	70~84	72~84	71~84	71~84	70~84	70~84	72~84	72~84	72~84	70~84	70~84	71~84	71~84	72~84	71~84	71~84	71~84	72~84	70~84	71~84	71~84	72~84	72~84	72~84
標準フック	25t																								
フック質量	450kg																								
標準巻掛本数	2																								

注) カウンタウエイト 35t、アウトリガ張出幅 5.6m

● FL性能 59.2mブーム+1.85m+フルオートラフィングジブ

(単位:t)

ジブ長さ 作業半径 (m)	8.5m					11.6m					14.7m					17.8m					20.9m				
	オフセット					オフセット					オフセット					オフセット					オフセット				
	5°	15°	30°	45°	60°	5°	15°	30°	45°	60°	5°	15°	30°	45°	60°	5°	15°	30°	45°	60°	5°	15°	30°	45°	60°
11.0	9.6																								
12.0	9.6	9.4				7.5																			
14.0	9.0	8.7	8.3			7.5	7.5				6.5					5.7									
16.0	8.4	8.3	7.7	7.5		7.5	7.4				6.5	6.5				5.7							5.0		
18.0	8.1	7.8	7.3	7.1	7.0	7.2	6.9	6.5			6.5	6.3				5.7	5.7						5.0		
20.0	7.5	7.3	6.9	6.7	6.6	7.0	6.5	6.1	5.9		6.3	6.0	5.5			5.7	5.5					5.0	5.0		
22.0		6.4	6.6	6.3	6.3	6.5	6.2	5.8	5.6	5.5	5.9	5.6	5.2	5.0		5.5	5.2	4.8				5.0	4.8		
24.0				5.9	6.0		5.8	5.5	5.3	5.3	5.6	5.3	5.0	4.8	4.7	5.2	4.9	4.6				4.8	4.5	4.2	
26.0								5.2	5.0	5.0		5.0	4.8	4.6	4.5		4.7	4.4	4.2			4.6	4.3	4.0	
28.0									4.4	4.7			4.5	4.4	4.3			4.2	4.0	3.9			4.1	3.8	3.6
30.0													4.2	4.2			4.0	3.8	3.8				3.6	3.5	
32.0																	3.7	3.6					3.5	3.3	3.3
34.0																								3.2	3.2
36.0																									3.1
θ(°)	72~84	72~84	73~84	72~84	73~84	72~84	72~84	72~84	71~84	72~84	71~84	71~84	72~84	72~84	73~84	72~84	73~84	72~84	74~84	72~84	72~84	72~84	72~84	73~84	73~84
標準フック	25t																								
フック質量	450kg																								
標準巻掛本数	2																								

注) カウンタウエイト 35t、アウトリガ張出幅 5.6m

TADANO ATF220G-5

■定格総荷重表

●FL性能 63.4mブーム+1.85m+フルオートラフィングジブ

(単位: t)

ジブ長さ 作業半径 (m)	8.5m					11.6m					14.7m					17.8m					20.9m				
	オフセット					オフセット					オフセット					オフセット					オフセット				
	5°	15°	30°	45°	60°	5°	15°	30°	45°	60°	5°	15°	30°	45°	60°	5°	15°	30°	45°	60°	5°	15°	30°	45°	60°
14.0	7.0	7.0				6.1					5.4														
16.0	6.8	6.6	6.3			6.1	6.0				5.4						4.7								
18.0	6.3	6.1	5.9	5.7		5.9	5.7	5.3			5.4	5.2				4.7						4.2			
20.0	6.0	5.8	5.5	5.3	5.3	5.5	5.3	5.0	4.8		5.2	4.9				4.7	4.5					4.2			
22.0	5.6	5.4	5.1	5.0	5.0	5.2	5.0	4.7	4.5	4.5	4.8	4.6	4.3			4.6	4.3					4.2	4.0		
24.0			4.8	4.7	4.7		4.7	4.4	4.3	4.2	4.5	4.3	4.1	3.9		4.3	4.0	3.8				4.0	3.7		
26.0				4.4			4.2	4.1	4.0		4.1	3.9	3.7	3.7		3.8	3.6					3.8	3.5	3.3	
28.0											3.9	3.8				3.4	3.3	3.2					3.4	3.1	
30.0																3.2	3.1	3.1					3.0	2.9	
32.0																	2.9	2.9					2.8	2.7	2.7
34.0																							2.6	2.6	
36.0																								2.4	
θ(°)	72~84	73~84	72~84	73~84	72~84	73~84	73~84	73~84	72~84	73~84	72~84	72~84	73~84	73~84	74~84	73~84	73~84	73~84	73~84	75~84	72~84	73~84	73~84	74~84	74~84
標準フック												7.8t													
フック質量												300kg													
標準巻掛本数												1													

注) カウンタウエイト 35t、アウトリガ張出幅 5.6m

●FM性能 55.0mブーム+1.85m+フルオートラフィングジブ

(単位: t)

ジブ長さ 作業半径 (m)	8.5m					11.6m					14.7m					17.8m					20.9m				
	オフセット					オフセット					オフセット					オフセット					オフセット				
	5°	15°	30°	45°	60°	5°	15°	30°	45°	60°	5°	15°	30°	45°	60°	5°	15°	30°	45°	60°	5°	15°	30°	45°	60°
11.0	11.5																								
12.0	11.5	11.5				10.0																			
14.0	11.5	11.5	11.4			10.0	10.0				6.9					6.7									
16.0		9.9	10.6	10.4	10.4	9.7	9.9	9.7			6.9					6.7						5.6			
18.0			8.2	8.9	9.3		8.1	9.1	8.9		6.9	6.9				6.7	6.7					5.6			
20.0				6.8				7.1	8.1	8.4		6.9	6.9			6.7						5.6	5.6		
22.0									6.6			6.6	6.9				6.3					5.6			
24.0												5.9	6.4			5.8	5.6					5.0			
26.0																5.5	5.1					4.8			
28.0																	4.8						4.3		
30.0																								3.9	
θ(°)	77~84	76~84	76~84	77~84	75~84	76~84	75~84	76~84	77~84	76~84	75~84	75~84	76~84	76~84	78~84	76~84	76~84	77~84	76~84	75~84	76~84	76~84	77~84	78~84	78~84
標準フック												25t													
フック質量												450kg													
標準巻掛本数												2													

注) カウンタウエイト 23.5t、アウトリガ張出幅 5.6m

ATF220G-5

TADANO ATF220G-5

■ 定格総荷重表注意事項

1. 定格総荷重表の性能区分A~Tは、下表のとおりです。

アウトリガ張出幅	カウンタウエイト					
	71t	47t	35t	23.5t	12t	0t
8.3m	A	B	C	D	E	F
7.0m	G	H	I	J	K	L
5.6m			M	N	O	P
4.6m					Q	R
2.74m						S、T

※同じ性能区分・ブーム長さでも、ブームの伸長状態によって定格総荷重が異なります。
 ※S、T性能の作業領域は下図のようになります。

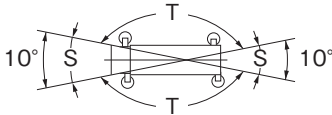

2. 定格総荷重は、つり具質量とフック質量（125tアタッチメントシーブ付フック：1,425kg、125tフック：1,350kg、80tフック：1,150kg、25tフック：450kg、7.8tフック：300kg）を含んだ値を示します。
3. 定格総荷重は、ブームのたわみを含んだ実際の作業半径に基づいています。
4. 定格総荷重表中の標準巻掛本数より少ない本数で使用する場合、最大荷重の上限は下表のとおりです。

巻掛本数	15本	13本	11本	10本	9本	8本	7本	6本	5本	4本	1本
最大荷重	108.2t	94.0t	80.0t	72.3t	65.0t	57.7t	50.5t	43.3t	36.2t	29.2t	7.3t

5. シングルトップ使用時の巻掛本数は1本（7.8tフック使用）で、定格総荷重はブームの定格総荷重からブームに取り付けられているフックの質量を差し引いた値とし、かつ上限は7.8tです。
6. 定格総荷重は、アウトリガを水平堅土上に設置したときの値です。
7. 定格総荷重表は、風による影響を含んでいません。瞬間最大風速が10m/s以上の風速では、クレーン作業を中止してください。
8. 定格総荷重表中の太線より上側はクレーンの強度に、下側はクレーンの安定に基づいています。
9. 「ピン無最大荷重」は、Bピン（ブーム固定ピン）を挿入していないときの定格総荷重の上限を示します。
10. 「θ(°)」は、無負荷状態で可能なブーム起伏角度範囲を示します。

ATF220G-5