

# TADANO ATF100G-4

■寸法図

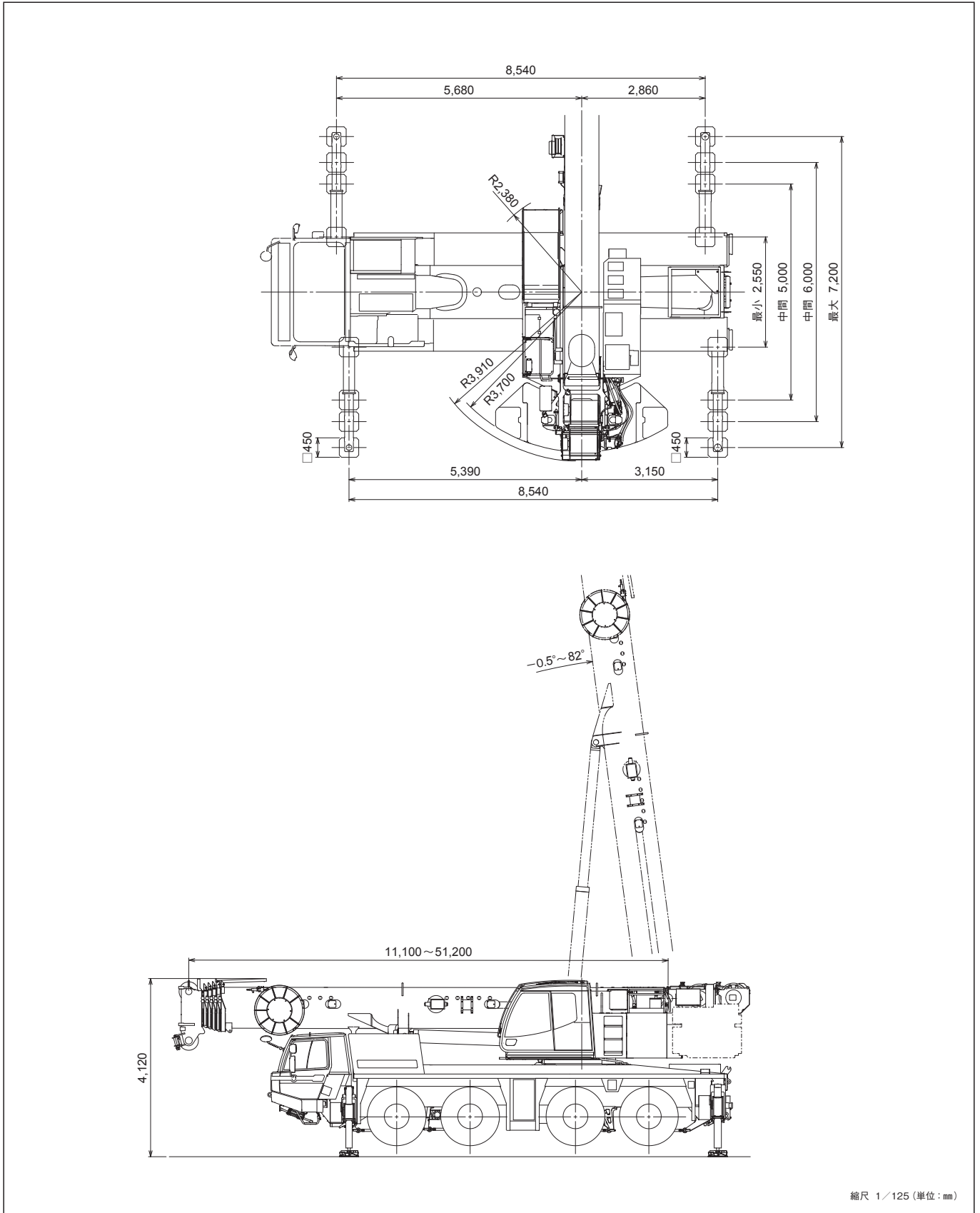

# TADANO ATF100G-4

## ■フック寸法

H: ヘッドシーブ中心とハッカ上面の距離

	55tフック	18tフック	5.6tフック
ブーム	2.0m	2.0m	
シングルトップ			2.8m
10m ジブ		2.9m	3.0m
18m ジブ			2.8m

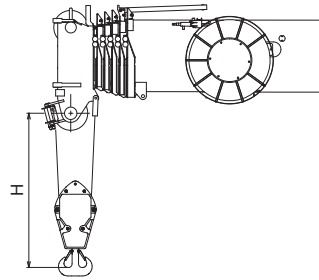

## ■カウンタウエイト (C/W) 組合せ

●各ウエイトの使用個数を示す

重量 呼称 (実荷重)	ウエイト ① 1.0t	ウエイト ② 4.5t	ウエイト ③ 2.9t	ウエイト ④ 1.2t	ウエイト ⑤ 4.4t	ウエイト ⑥ 2.7t	ウエイト ⑦ 4.6t	ウエイト ⑧ 4.0t
25t (25.3t)	1	1	1	1	1	1	1	1
21t (21.3t)	1	1	1	1	1	1	1	
15t (15.5t)	1	1	1		1	1		
9t (9.6t)	1	1	1	1				
5t (5.5t)	1	1						

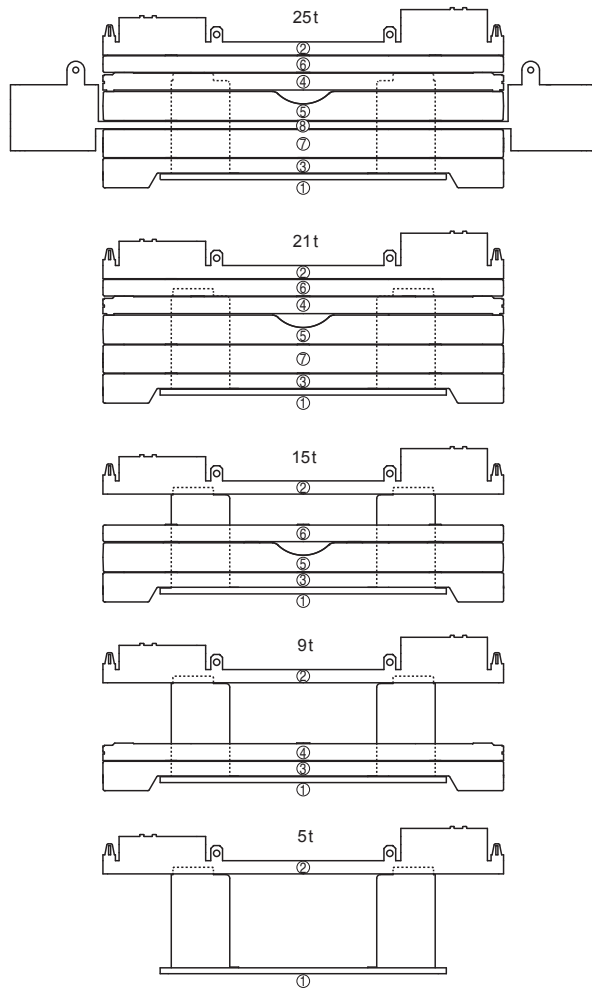
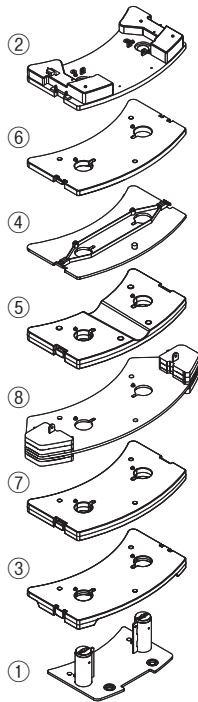

# TADANO ATF100G-4

■ 構内移動姿勢

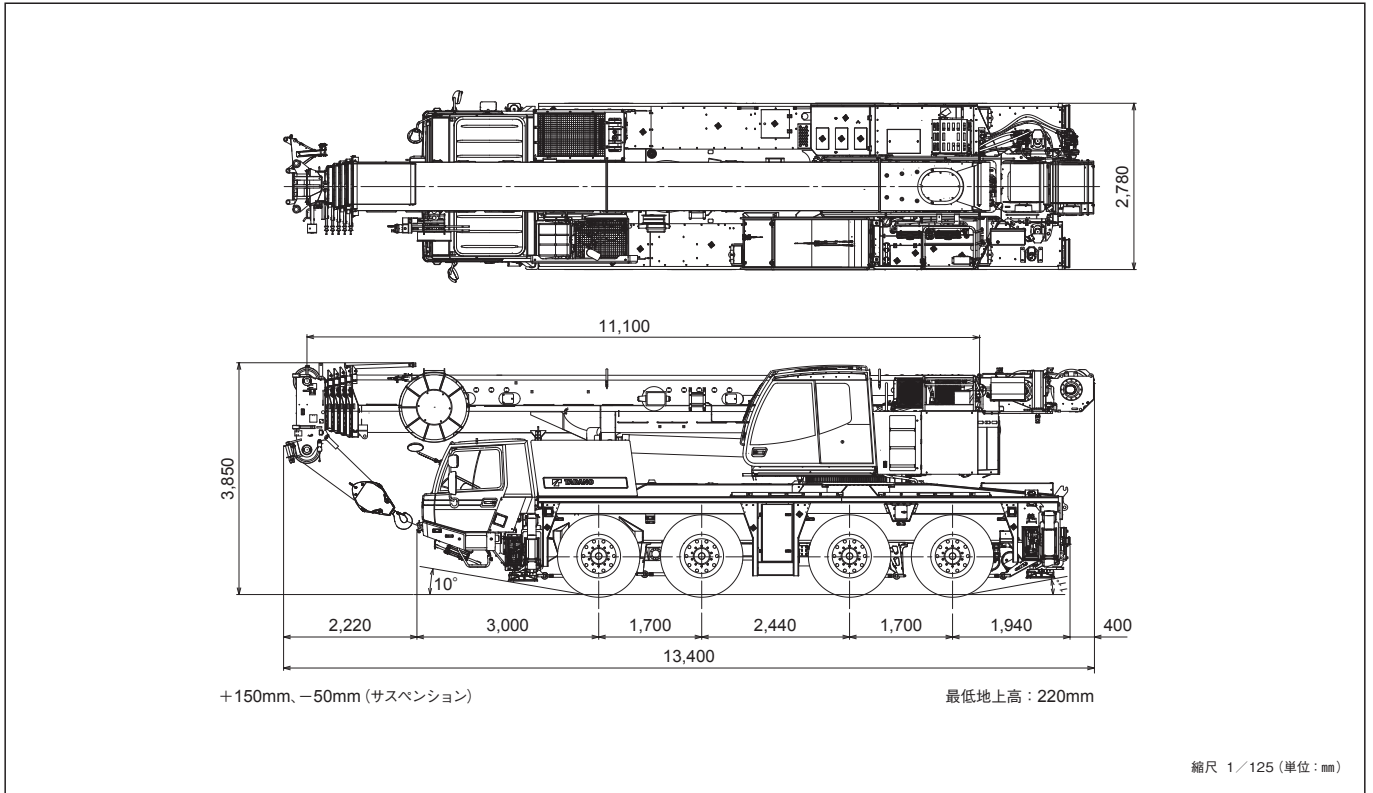

■ 最小直角通路幅

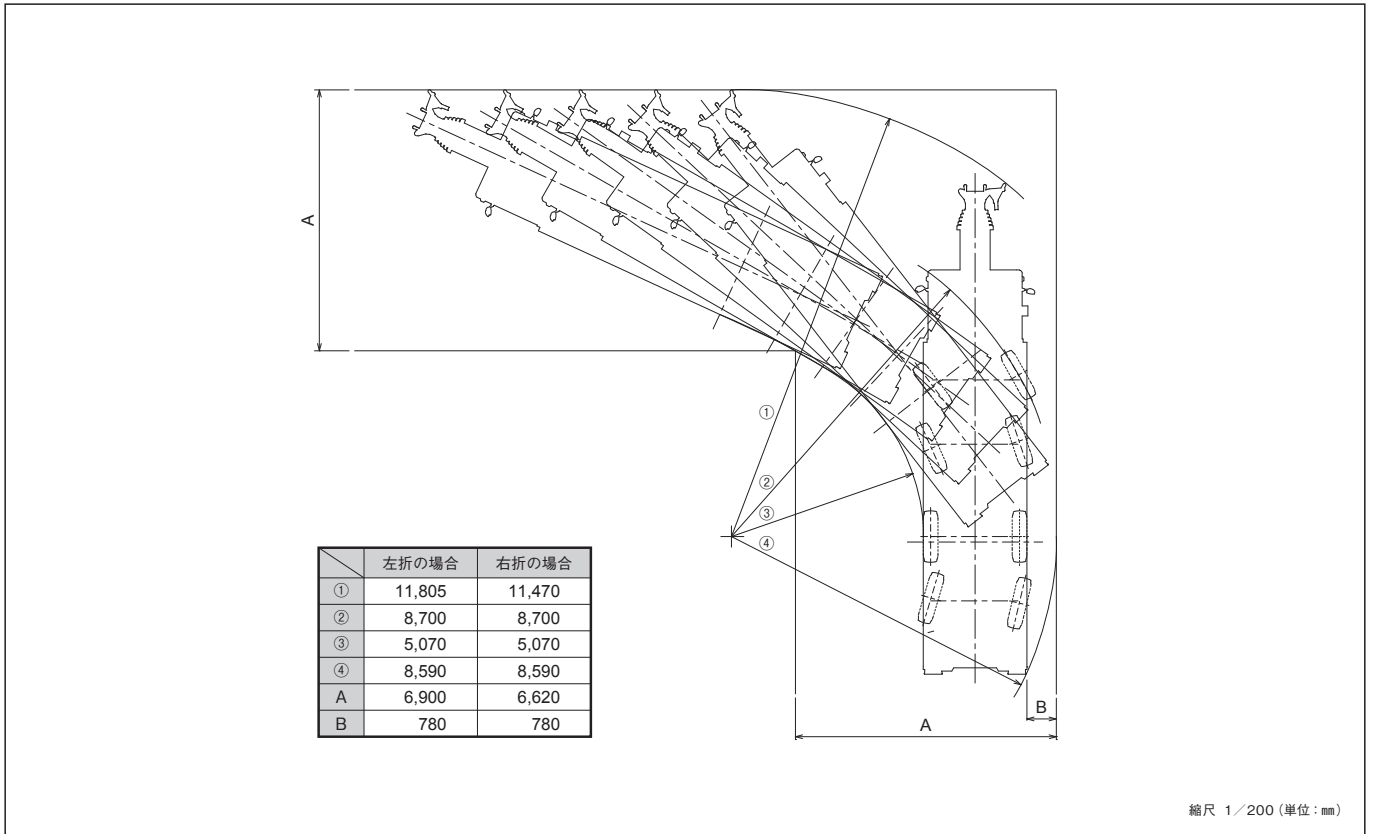

# TADANO ATF100G-4

■作業範囲図

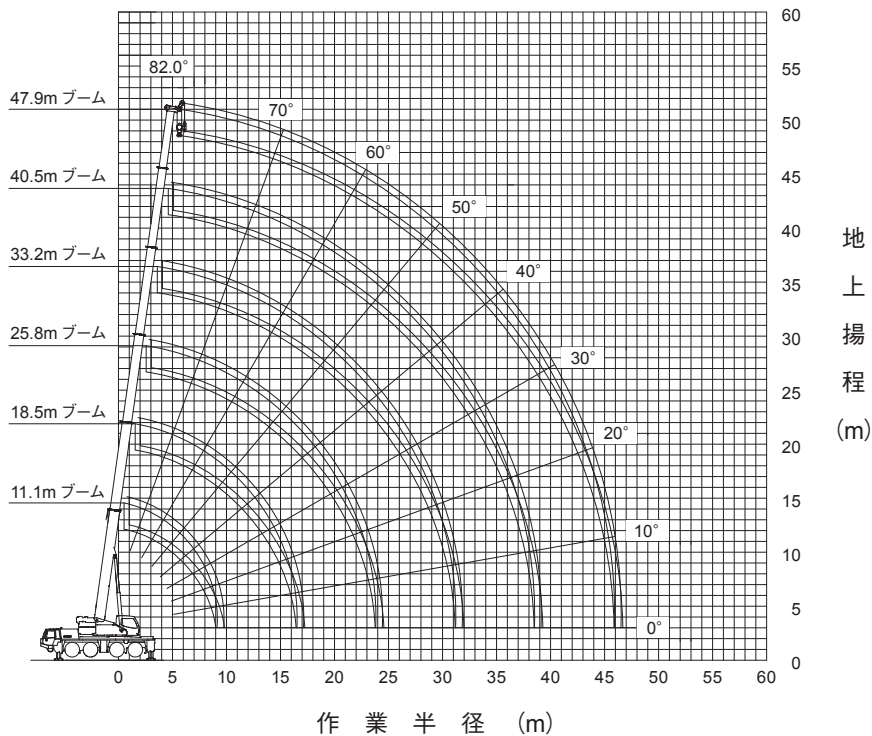
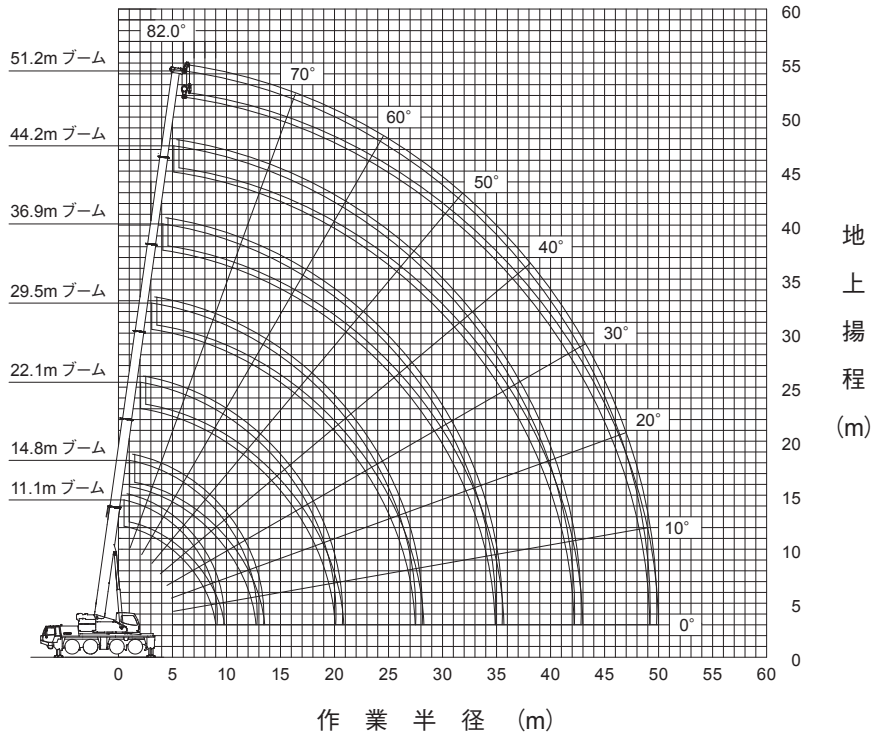

(注) 1. 上図はブームのたわみを含んでいません。  
2. A性能を図示しています。

縮尺 1/700

TADANO ATF100G-4

A性能

●ブーム

(単位:t)

Table with columns for boom length (1-22m), radius (1-22m), and various performance metrics like maximum load, hook weight, and extension ratio.

注)カウンタウエイト 25t、アウトリガ張出幅 7.2m ※印はアタッチメント付き、後方限定の値です。

B性能

●ブーム

(単位:t)

Table with columns for boom length (1-22m), radius (1-22m), and various performance metrics similar to section A.

注)カウンタウエイト 21t、アウトリガ張出幅 7.2m



# TADANO ATF100G-4

## ■ C性能

### ●ブーム

(単位: t)

性能ブロック	1	9	1	9	10	2	1	10	11	2	1	11	2	1	12	2	1	2	3	1	5	4	1	6	1	7	1	1	8		
性能番号	1	23	2	24	25	12	3	26	27	13	4	28	14	5	29	15	6	16	17	7	19	18	8	20	9	21	10	11	22		
ブーム長さ(m)	11.1	14.8			18.5			22.1			25.8			29.5			33.2			36.9			40.5			44.2			47.9		51.2
作業半径(m)	2.5	54.6			50.0			45.6			41.2			36.8			32.4			28.0			23.6			19.2			14.8		10.4
3.0	54.6	54.6	35.0	54.6	50.0	35.0	29.9																								
3.5	54.6	54.6	35.0	54.6	50.0	35.0	27.8	45.6	45.6	35.0	29.3																				
4.0	54.6	54.6	35.0	53.9	50.0	35.0	26.0	45.6	45.6	35.0	27.6	40.9	34.2	25.3																	
4.5	54.6	54.6	33.7	49.8	50.0	35.0	24.4	45.6	45.6	35.0	26.1	40.9	34.2	24.2																	
5.0	53.4	53.1	32.0	46.3	50.0	34.8	22.9	42.7	45.6	35.0	24.7	38.8	34.2	23.1	31.3	28.5	22.0														
6.0	45.5	45.1	29.1	40.4	45.3	32.0	20.6	37.2	44.8	33.7	22.4	34.6	34.2	21.2	31.1	28.5	21.1	23.8	20.9	17.3											
7.0	39.0	38.6	26.8	35.8	38.7	29.6	18.6	32.8	39.0	31.5	20.5	31.1	32.7	19.2	28.7	28.5	19.7	23.8	20.9	17.3	19.7	16.1	14.8	15.8	12.9						
8.0	33.7	33.0	24.8	32.1	33.2	27.6	17.0	29.3	33.7	29.5	18.9	27.7	30.8	17.2	26.1	28.5	18.3	23.8	20.9	16.2	19.7	16.1	14.8	15.8	12.9	12.9	11.0				
9.0	23.3	26.7	23.2	26.1	26.9	25.9	15.7	26.4	27.3	27.0	17.5	24.9	29.0	15.6	23.9	28.5	17.0	22.1	20.6	15.1	19.7	16.1	14.8	15.8	12.9	12.9	11.0	10.2			
10.0		22.1	21.8	21.6	22.3	24.1	14.5	21.9	22.8	24.6	16.3	22.3	24.3	14.3	21.9	23.9	15.5	20.7	19.5	14.1	18.5	16.1	14.1	15.8	12.9	12.9	11.0	10.2	8.9		
11.0		18.8	20.5	18.3	18.9	21.0	13.4	18.5	19.3	21.1	15.1	18.9	20.8	13.2	19.5	20.5	14.2	19.2	18.5	13.2	17.4	15.4	13.3	15.6	12.9	12.9	11.0	10.2	8.9		
12.0		16.0	17.8	15.5	16.2	18.3	12.5	15.7	16.6	18.4	14.0	16.2	18.1	12.2	16.7	17.7	13.1	17.3	17.6	12.1	16.4	14.6	12.6	14.8	12.6	12.9	11.0	10.2	8.9		
14.0				11.6	12.2	14.2	11.1	11.8	12.6	14.2	12.3	12.2	14.0	10.6	12.7	13.6	11.4	13.2	14.1	10.4	13.2	13.3	11.4	13.3	11.5	12.2	11.0	10.2	8.9		
16.0				8.9	9.5	11.4	10.0	9.1	9.9	11.4	10.9	9.5	11.2	9.3	10.0	10.9	10.0	10.5	11.3	9.1	10.5	11.5	10.3	10.6	10.5	10.8	10.6	10.2	8.9		
18.0								7.2	7.9	9.4	9.8	7.5	9.2	8.3	8.0	8.8	8.9	8.5	9.3	8.1	8.5	9.5	9.2	8.6	9.6	8.8	9.4	9.1	8.7		
20.0								5.7	6.5	7.9	8.3	6.0	7.7	7.5	6.5	7.3	8.0	7.0	7.7	7.2	6.9	7.9	8.2	7.1	8.0	7.3	7.8	7.6	7.6		
22.0												4.9	6.5	6.8	5.3	6.1	7.2	5.8	6.5	6.5	5.8	6.7	7.0	5.9	6.8	6.1	6.6	6.4	6.4		
24.0															4.4	5.2	6.2	4.8	5.6	5.9	4.8	5.8	6.1	4.9	5.8	5.1	5.6	5.4	5.4		
26.0															3.6	4.4	5.4	4.0	4.8	5.3	4.0	5.0	5.3	4.1	5.0	4.3	4.8	4.6	4.6		
28.0																		3.4	4.1	4.6	3.4	4.3	4.6	3.5	4.4	3.7	4.2	3.9	3.9		
30.0																				2.9	3.6	4.1	2.8	3.7	4.0	2.9	3.8	3.1	3.6	3.4	
32.0																						2.3	3.2	3.5	2.5	3.3	2.6	3.1	2.9	2.9	
34.0																							2.0	2.8	3.1	2.0	2.9	2.2	2.7	2.5	
36.0																								1.7	2.5	1.8	2.3	2.1	2.1		
38.0																									1.4	2.2	1.5	2.0	1.8	1.8	
40.0																										1.0	1.5	1.2	1.5	1.5	
42.0																											1.0	1.2	1.2	1.2	
44.0																												1.0	1.0	1.0	
46.0																													0.8	0.8	
48.0																														0.6	
ピン無最大荷重	21.5	21.8	23.0	17.6	21.4	27.6	15.4	17.7	20.1	21.3	22.3	17.8	20.3	16.3	18.0	18.8	20.3	17.3	18.4	16.1	18.3	16.1	14.8	15.8	12.9	12.9	11.0	10.2	8.9		
θ(°)	0~82	0~82		0~82				0~82				0~82			0~82			0~82			0~82			0~82			0~82	0~82	0~82	0~82	
伸長状態 (伸長割合%)																															
伸縮ブーム1	0	46	0	92	46	0	0	92	46	0	0	92	0	0	92	46	0	92	46	0	92	46	0	92	46	0	92	46	92	100	
伸縮ブーム2	0	0	0	0	46	0	0	46	46	0	0	46	46	0	46	46	0	46	46	0	46	46	0	46	46	0	46	46	92	100	
伸縮ブーム3	0	0	0	0	0	0	0	0	46	46	0	46	46	0	46	46	46	46	46	92	46	46	92	46	46	92	92	92	92	100	
伸縮ブーム4	0	0	0	0	0	46	0	0	46	46	0	46	46	46	92	46	46	46	46	92	46	46	92	46	92	46	92	92	92	100	
伸縮ブーム5	0	0	46	0	0	46	92	0	0	46	92	0	46	92	0	46	92	46	92	46	92	46	92	46	92	46	92	46	92	100	
標準フック	55t	55t		55t				55t				55t			55t			55t			55t		18t		18t		18t		18t	18t	
フック重量	650kg	650kg		650kg				650kg				650kg			650kg			650kg			650kg		300kg		300kg		300kg		300kg	300kg	
主巻時標準巻掛本数	11	11	7	11	10	7	6	9	7	6	8	7	5	6	5	5	5	4	4	3	3	3	3	3	3	2	2	2	2		
種巻時標準巻掛本数	11	11	7	9	7	6	8	7	6	6	7	5	6	5	5	5	4	4	3	3	3	3	3	3	3	2	2	2	2		
種巻時最大荷重	54.6	54.6	35.0	45.6	35.0	29.9	40.9	35.0	29.3	31.3	32.7	25.3	31.3	28.5	22.0	23.8	20.9	17.3	19.7	16.1	14.8	15.8	12.9	12.9	11.0	10.2	8.9				

注) カウンタウエイト 15t、アウトリガ張出幅 7.2m

## ■ D性能

### ●ブーム

(単位: t)

性能ブロック	1	9	1	9	10	2	1	10	11	2	1	11	2	1	12	2	1	2	3	1	5	4	1	6	1	7	1	1	8		
性能番号	1	23	2	24	25	12	3	26	27	13	4	28	14	5	29	15	6	16	17	7	19	18	8	20	9	21	10	11	22		
ブーム長さ(m)	11.1	14.8			18.5			22.1			25.8			29.5			33.2			36.9			40.5			44.2			47.9		51.2
作業半径(m)	2.5	54.6			50.0			45.6			41.2			36.8			32.4			28.0			23.6			19.2			14.8		10.4
3.0	54.6	54.6	35.0	54.6	50.0	35.0	29.9																								
3.5	54.6	54.6	35.0	54.6	50.0	35.0	27.8	45.6	45.6	35.0	29.3																				
4.0	54.6	54.6	35.0	53.9	50.0	35.0	26.0	45.6	45.6	35.0	27.6	40.9	34.2	25.3																	
4.5	54.6	54.6	33.7	49.8	50.0	35.0	24.4	45.6	45.6	35.0	26.1	40.9	34.2	24.2																	
5.0	52.5	52.1	32.0	46.3	50.0	34.8	22.9	42.7	45.6	35.0	24.7	38.8	34.2	23.1	31.3	28.5	22.0														
6.0	43.9	43.5	29.1	40.4	43.7	32.0	20.6	37.2	44.0	33.7	22.4	34.6	34.2	21.2	31.1	28.5	21.1	23.8	20.9	17.3											
7.0	36.4	35.6	26.8	35.0	35.9	29.6	18.6	32.8	36.4	31.5	20.5	31.1	32.7	19.2	28.7	28.5	19.7	23.8	20.9	17.3	19.7	16.1	14.8	15.8	12.9						
8.0	28.3	27.5	24.8	26.9	27.7	27.6	17.0	27.2	28.2	29.5	18.9	27.7	30.0	17.2	26.1	28.5	18.3	23.8	20.9	16.2	19.7	16.1	14.8	15.8	12.9	12.9	11.0				
9.0	22.8	22.0	23.2	21.4																											

# TADANO ATF100G-4

## ■ E 性能

### ● ブーム

(単位: t)

性能ブロック	1	9	1	9	10	2	1	10	11	2	1	11	2	1	12	2	1	2	3	1	5	4	1	6	1	7	1	1	8			
性能番号	1	23	2	24	25	12	3	26	27	13	4	28	14	5	29	15	6	16	17	7	19	18	8	20	9	21	10	11	22			
ブーム長さ(m)	11.1	14.8			18.5			22.1			25.8			29.5			33.2			36.9			40.5			44.2			47.9		51.2	
作業半径(m)	2.5	54.6			54.6			54.6			54.6			54.6			54.6			54.6			54.6			54.6			54.6			54.6
3.0	54.6	54.6	35.0	54.6	50.0	35.0	29.9																									
3.5	54.6	54.6	35.0	54.6	50.0	35.0	27.8	45.6	45.6	35.0	29.3																					
4.0	54.6	54.6	35.0	53.9	50.0	35.0	26.0	45.6	45.6	35.0	27.6	40.9	34.2	25.3																		
4.5	54.6	54.6	33.7	49.8	50.0	35.0	24.4	45.6	45.6	35.0	26.1	40.9	34.2	24.2																		
5.0	51.2	50.8	32.0	46.3	50.0	34.8	22.9	42.7	45.6	35.0	24.7	38.8	34.2	23.1	31.3	28.5	22.0															
6.0	42.8	42.4	29.1	40.4	42.6	32.0	20.6	37.2	42.8	33.7	22.4	34.6	34.2	21.2	31.1	28.5	21.1	23.8	20.9	17.3												
7.0	31.7	30.9	26.8	30.3	31.1	29.6	18.6	30.6	31.7	31.5	20.5	31.1	32.7	19.2	28.7	28.5	19.7	23.8	20.9	17.3	19.7	16.1	14.8	15.8	12.9							
8.0	24.2	23.4	24.8	22.7	23.6	26.4	17.0	23.1	24.2	26.5	18.9	23.6	26.2	17.2	24.4	25.7	18.3	23.8	20.9	16.2	19.7	16.1	14.8	15.8	12.9	12.9	11.0					
9.0	19.1	18.2	20.3	17.7	18.5	21.0	15.7	18.0	19.0	21.1	17.5	18.5	20.8	15.6	19.2	20.3	17.0	19.8	20.6	15.1	19.7	16.1	14.8	15.8	12.9	12.9	11.0	10.2				
10.0		14.7	16.6	14.1	14.9	17.2	14.5	14.4	15.3	17.3	16.3	14.9	17.1	14.3	15.5	16.6	15.5	16.2	17.2	14.1	16.2	16.1	14.1	15.8	12.9	12.9	11.0	10.2	8.9			
11.0		12.1	13.9	11.6	12.3	14.5	13.4	11.8	12.7	14.5	15.1	12.3	14.3	13.2	12.9	13.9	14.2	13.5	14.5	13.2	13.5	14.7	13.3	13.7	12.9	12.9	11.0	10.2	8.9			
12.0		10.1	11.8	9.6	10.3	12.4	12.4	9.8	10.7	12.4	13.0	10.3	12.2	12.2	10.8	11.8	13.1	11.4	12.3	12.1	11.4	12.6	12.6	11.6	12.6	11.8	11.0	10.2	8.9			
14.0				6.8	7.4	9.4	9.4	7.0	7.8	9.4	9.9	7.4	9.2	10.0	7.9	8.8	10.1	8.5	9.3	10.0	8.5	9.6	9.9	8.6	9.7	8.8	9.5	9.2	8.9			
16.0				4.9	5.5	7.4	7.4	5.1	5.8	7.4	7.9	5.4	7.2	7.9	5.9	6.8	8.0	6.4	7.3	7.9	6.4	7.5	7.9	6.6	7.6	6.8	7.4	7.2	7.1			
18.0								3.7	4.4	5.9	6.4	4.0	5.7	6.4	4.5	5.4	6.5	5.0	5.8	6.4	5.0	6.0	6.3	5.1	6.1	5.3	5.9	5.7	5.7			
20.0								2.7	3.4	4.9	5.3	3.0	4.6	5.3	3.4	4.3	5.4	3.9	4.7	5.2	3.9	4.9	5.2	4.0	5.0	4.2	4.8	4.5	4.5			
22.0												2.2	3.8	4.4	2.6	3.4	4.5	3.0	3.8	4.4	3.0	4.0	4.3	3.2	4.1	3.4	3.9	3.7	3.7			
24.0															1.9	2.7	3.8	2.4	3.1	3.6	2.3	3.3	3.6	2.5	3.4	2.7	3.2	3.0	3.0			
26.0																1.4	2.2	3.2	1.8	2.5	3.1	1.8	2.7	3.0	1.9	2.8	2.1	2.6	2.4	2.4		
28.0																					1.3	2.1	2.6	1.3	2.2	2.5	1.4	2.3	1.6	2.1	1.9	1.9
30.0																					1.0	1.7	2.2	0.9	1.8	2.1	1.0	1.9	1.2	1.5	1.5	
32.0																						1.0	1.7	2.2	0.9	1.8	2.1	1.0	1.9	1.2	1.5	1.1
34.0																							1.5	1.8	0.7	1.5	0.9	1.4	1.1	1.1		
36.0																								1.2	1.5	0.7	1.2	0.6	1.1	0.8	0.8	
38.0																									1.0	1.0	0.8	0.6	0.5			
ピン無最大荷重	21.5	21.8	23.0	17.6	21.4	27.6	15.4	17.7	20.1	21.3	22.3	17.8	20.3	16.3	18.0	18.8	20.3	17.3	18.4	16.1	18.3	16.1	14.8	15.8	12.9	12.9	11.0	10.2	8.9			
θ(°)	0~82	0~82		0~82				0~82				0~82			0~82			0~82			0~82			22~82	0~82	31~82	0~82	36~82	44~82			
伸縮ブーム1	0	46	0	92	46	0	0	92	46	0	0	92	46	0	92	46	0	92	46	0	92	46	0	92	46	0	92	46	92	100		
伸縮ブーム2	0	0	0	0	46	0	0	46	46	0	0	46	46	0	46	46	0	46	46	0	92	46	0	92	46	0	92	92	92	100		
伸縮ブーム3	0	0	0	0	0	0	0	46	46	0	0	46	46	0	46	46	0	46	46	0	92	46	0	92	46	0	92	92	92	100		
伸縮ブーム4	0	0	0	0	0	0	0	46	46	0	0	46	46	0	46	46	0	46	46	0	92	46	0	92	46	0	92	92	92	100		
伸縮ブーム5	0	0	46	0	0	46	92	0	0	46	92	0	46	92	0	46	92	0	46	92	46	92	46	92	46	92	46	92	92	100		
標準フック	55t	55t		55t				55t				55t			55t			55t			55t			18t		18t		18t		18t		
フック重量	650kg	650kg		650kg				650kg				650kg			650kg			650kg			650kg			300kg		300kg		300kg		300kg		
主巻時標準巻掛本数	11	11	7	11	10	7	6	9	7	6	8	7	5	6	5	5	5	4	4	4	3		3	3	3	2	2	2	2			
輔巻時標準巻掛本数	11	11	7	9	7	6	8	7	6	6	5	6	5	5	4	4	4	3	3	3	3		3	3	3	2	2	2	2			
挿巻時最大荷重	54.6	54.6	35.0	45.6	35.0	29.9		40.9	35.0	29.3		31.3	25.3	31.3	28.5	22.0	23.8	20.9	17.3	19.7	16.1	14.8	15.8	12.9	12.9	11.0	10.2	8.9				

注) カウンタウエイト 5t、アウトリガ張出幅 7.2m

## ■ F 性能

### ● ブーム

(単位: t)

性能ブロック	1	9	1	9	10	2	1	10	11	2	1	11	2	1	12	2	1	2	3	1	5	4	1	6	1	7	1	1	8			
性能番号	1	23	2	24	25	12	3	26	27	13	4	28	14	5	29	15	6	16	17	7	19	18	8	20	9	21	10	11	22			
ブーム長さ(m)	11.1	14.8			18.5			22.1			25.8			29.5			33.2			36.9			40.5			44.2			47.9		51.2	
作業半径(m)	2.5	54.6			54.6			54.6			54.6			54.6			54.6			54.6			54.6			54.6			54.6			54.6
3.0	54.6	54.6	35.0	54.6	50.0	35.0	29.9																									
3.5	54.6	54.6	35.0	54.6	50.0	35.0	27.8	45.6	45.6	35.0	29.3																					
4.0	54.6	54.6	35.0	53.9	50.0	35.0	26.0	45.6	45.6	35.0	27.6	40.9	34.2	25.3																		
4.5	54.4	54.0	33.7	49.8	50.0	35.0	24.4	45.6	45.6	35.0	26.1	40.9	34.2	24.2																		
5.0	49.1	48.7	32.0	46.3	48.9	34.8	22.9	42.7	45.6	35.0	24.7	38.8	34.2	23.1	31.3	28.5	22.0															
6.0	33.9	33.0	29.1	32.2	33.3	32.0	20.6	32.6	33.9	33.7	22.4	33.3	34.2	21.2	31.1	28.5	21.1	23.8	20.9	17.3												
7.0	23.2	22.3	24.9	21.6	22.5	25.7	18.6	21.9	23.2	25.8	20.5	22.6	25.5	19.2	23.4	24.9	19.7	23.8	20.9	17.3	19.7	16.1	14.8	15.8	12.9							
8.0	17.1	16.2	18.5	15.6	16.5	19.2	17.0	16.0	17.0	19.3	18.9	16.5	19.1	17.2	17.3	18.6	16.3	18.0	19.2	16.2	18.0	16.1	14.8	15.8	12.9	12.9	11.0					
9.0	13.2	12.4	14.5	11.8	12.6	15.1	15.2	12.1	13.1	15.2	15.8	12.6	15.0	15.6	13.3	14.5	16.1	14.0	15.1	15.1	14.0	15.4	14.8	14.2	12.9	12.9	11.0	10.2				
10.0		9.7	11.7	9.2	9.9	12.3	12.3	9.5	10.4	12.4	12.9	10.0	12.1	13.0	10.6	11.7	13.1	11.2	12.3	13.0	11.2	12.5	13.0	11.4	12.7	11.7	11.0	10.2	8.9			
11.0		7.8	9.6	7.3	8.0	10.2	10.2	7.5	8.4	10.3	10.8	8.0	10.0	10.9	8.6	9.6	11.0	9.2	10.2	10.9	9.2	10.4	10.8	9.4	10.5	9.6	10.3	10.0	8.9			
12.0			6.3	8.0	5.8	6.5																										

TADANO ATF100G-4

G性能

●ブーム

(単位:t)

Table with columns for boom length (11.1 to 48.0m), boom radius (2.5 to 48.0m), and various performance metrics like bin capacity, angle, and weight. Includes a section for '伸長状態 (伸長割合%)' with 5m increments.

注) カウンタウエイト 25t、アウトリガ張出幅 6.0m

H性能

●ブーム

(単位:t)

Table with columns for boom length (11.1 to 48.0m), boom radius (2.5 to 48.0m), and various performance metrics like bin capacity, angle, and weight. Includes a section for '伸長状態 (伸長割合%)' with 5m increments.

注) カウンタウエイト 21t、アウトリガ張出幅 6.0m





TADANO ATF100G-4

K性能

●ブーム

(単位:t)

Table with columns for boom length (11.1, 14.8, 18.5, 22.1, 25.8, 29.5, 33.2, 36.9, 40.5, 44.2, 47.9, 51.2) and rows for various performance metrics including hook weight, boom length, and lifting capacity.

注)カウンタウエイト 5t、アウトリガ張出幅 6.0m

L性能

●ブーム

(単位:t)

Table with columns for boom length (11.1, 14.8, 18.5, 22.1, 25.8, 29.5, 33.2, 36.9, 40.5, 44.2, 47.9, 51.2) and rows for various performance metrics including hook weight, boom length, and lifting capacity.

注)カウンタウエイト 0t、アウトリガ張出幅 6.0m



# TADANO ATF100G-4

## M性能

### ●ブーム

(単位:t)

性能ブロック	1	9	1	9	10	2	1	10	11	2	1	11	2	1	12	2	1	2	3	1	5	4	1	6	1	7	1	1	8		
性能番号	1	23	2	24	25	12	3	26	27	13	4	28	14	5	29	15	6	16	17	7	19	18	8	20	9	21	10	11	22		
ブーム長さ(m)	11.1	14.8			18.5			22.1			25.8			29.5			33.2			36.9			40.5			44.2			47.9		51.2
作業半径(m)	2.5	54.6			54.6			54.6			54.6			54.6			54.6			54.6			54.6			54.6			54.6		54.6
2.5	54.6																														
3.0	54.6	54.6	35.0	54.6	50.0	35.0	29.9																								
3.5	54.6	54.6	35.0	54.6	50.0	35.0	27.8	45.6	45.6	35.0	29.3																				
4.0	54.6	54.6	35.0	53.9	50.0	35.0	26.0	45.6	45.6	35.0	27.6	40.9	34.2	25.3																	
4.5	53.3	52.9	33.7	49.8	50.0	35.0	24.4	45.6	45.6	35.0	26.1	40.9	34.2	24.2																	
5.0	48.9	48.5	32.0	46.3	48.6	34.8	22.9	42.7	45.6	35.0	24.7	38.8	34.2	23.1	31.3	28.5	22.0														
6.0	41.9	41.4	29.1	40.4	41.6	32.0	20.6	37.2	41.9	33.7	22.4	34.6	34.2	21.2	31.1	28.5	21.1	23.8	20.9	17.3											
7.0	36.3	35.5	26.8	35.0	35.7	29.6	18.6	32.8	36.2	31.5	20.5	31.1	32.7	19.2	28.7	28.5	19.7	23.8	20.9	17.3	19.7	16.1	14.8	15.8	12.9						
8.0	28.9	28.2	24.8	27.6	28.4	27.6	17.0	27.9	28.8	29.5	18.9	27.7	30.5	17.2	26.1	28.5	18.3	23.8	20.9	16.2	19.7	16.1	14.8	15.8	12.9	12.9	11.0				
9.0	23.3	23.1	23.2	22.6	23.3	25.4	15.7	22.8	23.7	25.5	17.5	23.3	25.2	15.6	23.8	24.8	17.0	22.1	20.6	15.1	19.7	16.1	14.8	15.8	12.9	12.9	11.0	10.2			
10.0	19.3	21.0	18.9	19.5	21.5	14.5	19.1	19.9	21.6	16.3	19.5	21.4	14.3	20.1	21.0	15.5	20.6	19.5	14.1	18.5	16.1	14.1	15.8	12.9	12.9	11.0	10.2	8.9			
11.0	16.5	18.1	16.0	16.7	18.6	13.4	16.3	17.0	18.7	15.1	16.7	18.5	13.2	17.2	18.1	14.2	17.7	18.5	13.2	17.4	15.4	13.3	15.6	12.9	12.9	11.0	10.2	8.9			
12.0	14.3	15.8	13.8	14.4	16.3	12.5	14.0	14.8	16.3	14.0	14.4	16.1	12.2	14.9	15.8	13.1	15.4	16.3	12.1	15.4	14.6	12.6	14.8	12.6	12.9	11.0	10.2	8.9			
14.0			10.5	11.1	12.9	11.1	10.7	11.4	12.9	12.3	11.1	12.7	10.6	11.5	12.4	11.4	12.0	12.8	10.4	12.0	13.0	11.4	12.2	11.5	12.2	11.0	10.2	8.9			
16.0				8.2	8.8	10.5	10.0	8.4	9.1	10.5	10.9	8.7	10.3	9.3	9.2	10.0	10.0	9.6	10.4	9.1	9.6	10.6	10.3	9.8	10.5	10.0	10.5	10.2	8.9		
18.0								6.7	7.4	8.8	9.2	7.0	8.5	8.3	7.4	8.2	8.9	7.9	8.6	8.1	7.9	8.8	9.1	8.0	8.9	8.2	8.7	8.5	8.5		
20.0								5.4	6.1	7.4	7.8	5.7	7.2	7.5	6.1	6.9	7.9	6.5	7.2	7.2	6.5	7.4	7.7	6.6	7.5	6.8	7.3	7.1	7.1		
22.0												4.6	6.1	6.7	5.0	5.8	6.8	5.4	6.2	6.5	5.4	6.3	6.6	5.6	6.4	5.7	6.2	6.0	6.0		
24.0															4.2	4.9	5.9	4.6	5.3	5.8	4.5	5.4	5.7	4.7	5.5	4.9	5.4	5.1	5.1		
26.0															3.5	4.2	5.2	3.8	4.5	5.0	3.8	4.7	5.0	3.9	4.8	4.1	4.6	4.4	4.4		
28.0																		3.2	3.9	4.4	3.2	4.1	4.4	3.3	4.2	3.5	4.0	3.8	3.8		
30.0																		2.7	3.4	3.9	2.7	3.6	3.8	2.8	3.6	3.0	3.5	3.2	3.2		
32.0																				3.9	2.7	3.6	3.4	2.4	3.2	2.5	3.0	2.8	2.8		
34.0																					1.8	2.7	3.0	1.9	2.8	2.1	2.6	2.4	2.4		
36.0																							1.5	2.4	1.8	2.3	2.0	2.0	2.0		
38.0																							1.2	2.1	1.4	2.0	1.7	1.7	1.7		
40.0																									1.1	1.7	1.4	1.4	1.4		
42.0																									0.8	1.4	1.1	1.1	1.1		
44.0																													0.8		
46.0																													0.6		
48.0																													0.6		
ビン無最大荷重	21.5	21.8	23.0	17.6	21.4	27.6	15.4	17.7	20.1	21.3	22.3	17.8	20.3	16.3	18.0	18.8	20.3	17.3	18.4	16.1	18.3	16.1	14.8	15.8	12.9	12.9	11.0	10.2	8.9		
θ(°)	0~82	0~82		0~82				0~82				0~82			0~82			0~82			0~82			0~82			0~82	0~82	0~82		
伸長状態(伸長割合%)																															
伸縮ブーム1	0	46	0	92	46	0	0	92	46	0	0	92	0	0	92	46	0	92	46	0	92	46	0	92	0	92	46	92	100		
伸縮ブーム2	0	0	0	0	46	0	0	46	46	0	0	46	46	0	46	46	0	46	46	0	92	46	92	92	92	92	92	92	100		
伸縮ブーム3	0	0	0	0	0	0	0	46	46	46	0	46	46	0	46	46	46	46	92	46	92	46	92	92	92	92	92	92	100		
伸縮ブーム4	0	0	0	0	0	46	0	0	46	46	0	46	92	46	46	92	46	46	92	46	92	46	92	92	92	92	92	92	100		
伸縮ブーム5	0	0	46	0	0	46	92	0	0	46	92	0	46	92	0	46	92	46	92	46	92	46	92	92	92	92	92	92	100		
標準フック	55t	55t		55t				55t				55t			55t			55t			55t		18t	18t	18t	18t	18t	18t	18t		
フック重量	650kg	650kg		650kg				650kg				650kg			650kg			650kg			650kg		300kg	300kg	300kg	300kg	300kg	300kg	300kg		
主巻時標準巻掛本数	11	11	7	11	10	7	6	9	7	6	8	7	5	6	5	5	5	4	4	4	3	3	3	3	3	2	2	2			
種巻時標準巻掛本数	11	11	7	9	7	6	8	7	6	6	5	6	5	5	5	4	4	3	3	3	3	3	3	3	2	2	2	2			
種巻時最大荷重	54.6	54.6	35.0	45.6	35.0	29.9	40.9	35.0	29.3	31.3	25.3	31.3	28.5	22.0	23.8	20.9	17.3	19.7	16.1	14.8	15.8	12.9	12.9	11.0	10.2	8.9					

注)カウンタウエイト 25t、アウトリガ張出幅 5.0m

## N性能

### ●ブーム

(単位:t)

性能ブロック	1	9	1	9	10	2	1	10	11	2	1	11	2	1	12	2	1	2	3	1	5	4	1	6	1	7	1	1	8		
性能番号	1	23	2	24	25	12	3	26	27	13	4	28	14	5	29	15	6	16	17	7	19	18	8	20	9	21	10	11	22		
ブーム長さ(m)	11.1	14.8			18.5			22.1			25.8			29.5			33.2			36.9			40.5			44.2			47.9		51.2
作業半径(m)	2.5	54.6			54.6			54.6			54.6			54.6			54.6			54.6			54.6			54.6			54.6		54.6
2.5	54.6																														
3.0	54.6	54.6	35.0	54.6	50.0	35.0	29.9																								
3.5	54.6	54.6	35.0	54.6	50.0	35.0	27.8	45.6	45.6	35.0	29.3																				
4.0	54.6	54.6	35.0	53.9	50.0	35.0	26.0	45.6	45.6	35.0	27.6	40.9	34.2	25.3																	
4.5	54.6	54.6	33.7	49.8	50.0	35.0	24.4	45.6	45.6	35.0	26.1	40.9	34.2	24.2																	
5.0	50.5	50.1	32.0	46.3	50.0	34.8	22.9	42.7	45.6	35.0	24.7	38.8	34.2	23.1	31.3	28.5	22.0														
6.0	42.3	41.8	29.1	40.4	41.9	32.0	20.6	37.2	42.3	33.7	22.4	34.6	34.2	21.2	31.1	28.5	21.1	23.8	20.9	17.3											
7.0	32.6	31.8	26.8	31.3	32.1	29.6	18.6	31.6	32.5	31.5	20.5	31.1	32.7	19.2	28.7	28.5	19.7	23.8	20.9	17.3	19.7	16.1									

TADANO ATF100G-4

● O性能

● ブーム

(単位:t)

Table with columns for boom length (11.1, 14.8, 18.5, 22.1, 25.8, 29.5, 33.2, 36.9, 40.5, 44.2, 47.9, 51.2) and rows for performance metrics like lifting capacity, hook weight, and boom length.

注) カウンタウエイト 15t、アウトリガ張出幅 5.0m

● P性能

● ブーム

(単位:t)

Table with columns for boom length (11.1, 14.8, 18.5, 22.1, 25.8, 29.5, 33.2, 36.9, 40.5, 44.2, 47.9, 51.2) and rows for performance metrics like lifting capacity, hook weight, and boom length.

注) カウンタウエイト 9t、アウトリガ張出幅 5.0m



# TADANO ATF100G-4

### ■ Q性能

#### ● ブーム

(単位:t)

性能ブロック	1	9	1	9	10	2	1	10	11	2	1	11	2	1	12	2	1	2	3	1	5	4	1	6	1	7	1	1	8		
性能番号	1	23	2	24	25	12	3	26	27	13	4	28	14	5	29	15	6	16	17	7	19	18	8	20	9	21	10	11	22		
ブーム長さ(m)	11.1	14.8			18.5			22.1			25.8			29.5			33.2			36.9			40.5			44.2			47.9		51.2
作業半径(m)	2.5	54.6			54.6			54.6			54.6			54.6			54.6			54.6			54.6			54.6			54.6		54.6
2.5	54.6																														
3.0	54.6	54.6	35.0	54.6	50.0	35.0	29.9																								
3.5	54.6	54.6	35.0	54.6	50.0	35.0	27.8	45.6	45.6	35.0	29.3																				
4.0	54.6	54.6	35.0	53.9	50.0	35.0	26.0	45.6	45.6	35.0	27.6	40.9	34.2	25.3																	
4.5	45.4	44.4	33.7	43.5	44.8	35.0	24.4	44.0	45.5	35.0	26.1	40.9	34.2	24.2																	
5.0	35.4	34.5	32.0	33.8	34.8	34.8	22.9	34.2	35.5	35.0	24.7	34.8	34.2	23.1	31.3	28.5	22.0														
6.0	24.0	23.2	25.5	22.6	23.5	26.2	20.6	22.9	24.0	26.3	22.4	23.5	26.0	21.2	24.3	25.6	21.1	23.8	20.9	17.3											
7.0	17.7	17.0	19.0	16.4	17.2	19.6	18.6	16.7	17.7	19.7	20.3	17.2	19.5	19.2	17.9	19.0	19.7	18.5	19.6	17.3	18.6	16.1	14.8	15.8	12.9						
8.0	13.7	13.0	14.9	12.5	13.2	15.4	15.5	12.7	13.6	15.5	16.1	13.2	15.3	16.1	13.8	14.9	16.3	14.4	15.4	16.1	14.4	15.7	14.8	14.6	12.9	12.9	11.0				
9.0	10.9	10.2	12.0	9.7	10.4	12.5	12.6	10.0	10.8	12.6	13.1	10.4	12.4	13.2	11.0	12.0	13.3	11.6	12.5	13.2	11.6	12.8	13.2	11.8	12.9	12.0	11.0	10.2			
10.0		8.2	9.9	7.7	8.4	10.4	10.4	8.0	8.8	10.5	11.0	8.4	10.2	11.0	8.9	9.9	11.1	9.5	10.4	11.0	9.5	10.6	11.0	9.7	10.7	9.9	10.5	10.2	8.9		
11.0		6.7	8.3	6.2	6.8	8.8	8.8	6.4	7.2	8.8	9.3	6.8	8.6	9.4	7.4	8.3	9.5	7.9	8.7	9.4	7.9	9.0	9.3	8.1	9.1	8.3	8.9	8.6	8.6		
12.0		5.5	7.0	5.0	5.6	7.5	7.5	5.2	6.0	7.5	8.0	5.6	7.3	8.1	6.1	7.0	8.2	6.6	7.5	8.1	6.6	7.7	8.0	6.8	7.8	7.0	7.6	7.3	7.3		
14.0				3.2	3.8	5.6	5.6	3.4	4.2	5.6	6.1	3.8	5.5	6.1	4.3	5.1	6.2	4.8	5.6	6.1	4.8	5.8	6.1	4.9	5.9	5.1	5.7	5.4	5.4		
16.0				2.0	2.6	4.3	4.3	2.2	2.9	4.3	4.7	2.5	4.1	4.8	3.0	3.8	4.9	3.5	4.2	4.8	3.4	4.4	4.7	3.6	4.5	3.8	4.3	4.1	4.1		
18.0								1.3	2.0	3.4	3.8	1.6	3.2	3.8	2.0	2.8	3.9	2.5	3.2	3.8	2.5	3.4	3.7	2.6	3.5	2.8	3.3	3.1	3.1		
20.0									1.3	2.6	3.0	0.9	2.4	3.0	1.3	2.1	3.1	1.7	2.5	3.0	1.7	2.7	3.0	1.9	2.7	2.1	2.6	2.3	2.3		
22.0													1.8	2.4				1.5	2.5	1.2	1.9	2.4	1.1	2.1	2.3	1.3	2.1	1.7	1.7		
24.0																		1.0	2.0	1.4	1.9	1.6	1.9	1.6	1.0	1.5	1.2	1.2	1.2		
26.0																			1.6		1.0	1.5	1.2	1.1	1.1	1.1	1.1	1.1	1.1		
28.0																					1.2	0.8	0.8	0.6	0.9	0.6	0.7	0.7	0.7		
30.0																						0.9	0.5	0.8	0.6	0.6	0.6	0.6	0.6		
32.0																															
ピン無最大荷重	21.5	21.8	23.0	17.6	21.4	27.6	15.4	17.7	20.1	21.3	22.3	17.8	20.3	16.3	18.0	18.8	20.3	17.3	18.4	16.1	18.3	16.1	14.8	15.8	12.9	12.9	11.0	10.2	8.9		
θ(°)	0~82	0~82		0~82				0~82				27~82	0~82		39~82	0~82		43~82	0~82		53~82	20~82	0~82	55~82	38~82	58~82	50~82	60~82	62~82		
伸長状態 (伸長割合%)																															
伸縮ブーム1	0	46	0	92	46	0	0	92	46	0	0	92	0	0	92	46	0	92	46	0	92	46	0	92	46	0	92	46	92	100	
伸縮ブーム2	0	0	0	0	46	0	0	46	46	0	0	46	46	0	46	46	0	46	46	0	46	46	0	92	46	92	92	92	92	100	
伸縮ブーム3	0	0	0	0	0	0	0	0	46	46	0	46	46	0	46	46	46	46	46	46	46	46	92	46	92	92	92	92	92	100	
伸縮ブーム4	0	0	0	0	0	46	0	0	46	46	0	46	46	0	46	92	46	46	46	46	46	46	92	46	92	92	92	92	92	100	
伸縮ブーム5	0	0	46	0	0	46	92	0	0	46	92	0	46	92	0	46	92	46	92	46	92	46	92	46	92	46	92	46	92	100	
標準フック	55t	55t		55t				55t				55t			55t			55t			55t	18t		18t		18t		18t	18t		
フック重量	650kg	650kg		650kg				650kg				650kg			650kg			650kg			650kg	300kg		300kg		300kg		300kg	300kg		
主巻時標準巻掛本数	11	11	7	11	10	7	6	9	7	6	8	7	5	6	5	5	4	4	3	3	3	3	3	3	3	2	2	2			
輔巻時標準巻掛本数	11	11	7	9	7	6	8	8	7	6	6	7	5	6	5	5	4	4	3	3	3	3	3	3	3	2	2	2			
挿巻時最大荷重	54.6	54.6	35.0	45.6	35.0	29.9	40.9	35.0	29.3	31.3	25.3	31.3	28.5	22.0	23.8	20.9	17.3	18.6	16.1	18.3	16.1	14.8	15.8	12.9	12.9	11.0	10.2	8.9			

注) カウンタウエイト 5t、アウトリガ張出幅 5.0m

### ■ R性能

#### ● ブーム

(単位:t)

性能ブロック	1	9	1	9	10	2	1	10	11	2	1	11	2	1	12	2	1	2	3	1	5	4	1	6	1	7	1	1	8		
性能番号	1	23	2	24	25	12	3	26	27	13	4	28	14	5	29	15	6	16	17	7	19	18	8	20	9	21	10	11	22		
ブーム長さ(m)	11.1	14.8			18.5			22.1			25.8			29.5			33.2			36.9			40.5			44.2			47.9		51.2
作業半径(m)	2.5	54.6			54.6			54.6			54.6			54.6			54.6			54.6			54.6			54.6			54.6		54.6
2.5	54.6																														
3.0	54.6	54.6	35.0	54.6	50.0	35.0	29.9																								
3.5	54.6	54.6	35.0	54.6	50.0	35.0	27.8	45.6	45.6	35.0	29.3																				
4.0	44.0	42.8	35.0	41.8	43.2	35.0	26.0	42.3	44.1	35.0	27.6	40.9	34.2	25.3																	
4.5	31.8	30.8	33.7	30.0	31.2	34.9	24.4	30.5	31.9	35.0	26.1	31.2	34.2	24.2																	
5.0	24.6	23.7	26.4	22.9	24.0	27.2	22.9	23.3	24.6	27.4	24.7	24.0	27.0	23.1	24.9	26.5	22.0														
6.0	16.2	15.5	17.8	14.9	15.7	18.5	18.6	15.2	16.3	18.6	19.2	15.8	18.3	19.4	16.5	17.8	19.5	17.3	18.5	17.3											
7.0	11.6	10.9	12.9	10.4	11.1	13.6	13.7	10.7	11.6	13.7	14.3	11.2	13.4	14.4	11.8	13.0	14.5	12.5	13.6	14.4	12.5	13.9	14.3	12.7	12.9						
8.0	8.7	8.0	9.9	7.5	8.2	10.5	10.5	7.8	8.7	10.6	11.1	8.3	10.3	11.2	8.9	9.9	11.3	9.5	10.5	11.2	9.5	10.8	11.2	9.7	10.9	9.9	10.6				
9.0	6.7	6.0	7.8	5.6	6.2	8.3	8.4	5.8	6.6	8.4	8.9	6.2	8.2	9.0	6.8	7.8	9.1	7.4	8.3	9.0	7.4	8.6	9.0	7.6	8.7	7.8	8.5	8.2			
10.0		4.6	6.2	4.1	4.7	6.8	6.8	4.4	5.2	6.8	7.3	4.8	6.6	7.4	5.3	6.3	7.5	5.9	6.8	7.4	5.9	7.0	7.4	6.0	7.1	6.3	6.9	6.6	6.6		
11.0		3.5	5.1	3.0	3.6	5.6	5.6	3.2	4.0	5.6	6.1	3.6	5.4	6.2	4.2	5.1	6.3	4.7	5.5	6.2	4.7	5.8	6.1	4.9	5.9	5.1	5.7	5.4	5.4		
12.0		2.6	4.1	2.1	2.7	4.6	4.7	2.4	3.1	4.7	5.1	2.7	4.5	5.2	3.3	4.1	5.3	3.8	4.6	5.2	3.8	4.8	5.2	3.9	4.9	4.1	4.7	4.5	4.5		
14.0				0.9	1.4	3.2	3.3	1.1	1.8	3.3	3.7	1.4	3.1	3.8	1.9	2.8	3.9	2.4	3.2	3.8	2.4	3.4	3.7	2.6	3.5	2.8	3.3	3.1	3.1		
16.0						2.3																									

# TADANO ATF100G-4

## ■ S 性能

### ● ブーム

(単位：t)

性能ブロック	1	9	1	9	10	2	1	10	11	2	1	
性能番号	1	23	2	24	25	12	3	26	27	13	4	
ブーム長さ(m)	11.1		14.8		18.5				22.1			
作業半径(m)	11.1		14.8		18.5				22.1			
2.5	54.6											
3.0	47.2	46.7	35.0	46.4	46.9	35.0	29.9					
3.5	41.6	41.2	35.0	40.8	41.3	35.0	27.8	41.0	41.6	35.0	29.3	
4.0	37.3	36.9	35.0	36.6	37.0	35.0	26.0	36.8	37.3	35.0	27.6	
4.5	33.9	33.5	33.7	33.2	33.6	35.0	24.4	33.3	33.9	35.0	26.1	
5.0	31.0	30.6	31.8	30.3	30.8	32.2	22.9	30.5	31.1	32.3	24.7	
6.0	26.5	26.1	27.3	25.8	26.2	27.7	20.6	26.0	26.5	27.7	22.4	
7.0	23.0	22.6	23.8	22.3	22.7	24.2	18.6	22.5	23.0	24.2	20.5	
8.0	18.3	17.6	19.6	17.0	17.8	20.3	17.0	17.3	18.3	20.4	18.9	
9.0	14.6	13.8	15.7	13.3	14.0	16.3	15.7	13.6	14.5	16.4	17.0	
10.0		11.2	12.9	10.7	11.3	13.5	13.6	10.9	11.8	13.6	14.1	
11.0		9.2	10.8	8.7	9.3	11.4	11.4	8.9	9.7	11.5	12.0	
12.0		7.6	9.2	7.1	7.8	9.7	9.8	7.4	8.2	9.8	10.3	
14.0				4.9	5.5	7.4	7.4	5.1	5.9	7.4	7.9	
16.0				3.4	3.9	5.7	5.8	3.6	4.3	5.8	6.2	
18.0								2.4	3.1	4.6	5.0	
20.0								1.6	2.3	3.7	4.1	
ピン無最大荷重	21.5	21.8	23.0	17.6	21.4	27.6	15.4	17.7	20.1	21.3	22.3	
θ(°)	0~82		0~82		0~82				0~82			
伸長状態 (伸長割合%)												
伸縮ブーム1	0	46	0	92	46	0	0	92	46	0	0	
伸縮ブーム2	0	0	0	0	46	0	0	46	46	0	0	
伸縮ブーム3	0	0	0	0	0	0	0	46	46	46	0	
伸縮ブーム4	0	0	0	0	0	46	0	0	46	0	46	
伸縮ブーム5	0	0	46	0	0	46	92	0	0	46	92	
標準フック	55t	55t		55t	55t		55t	55t	19t		55t	
フック質量	650kg	650kg		650kg	650kg		650kg	650kg	300kg		650kg	
主巻時標準巻掛本数	11	10	7	10	7	6		9	7	6		
補巻時標準巻掛本数	11	10	7	9	7	6		8	7	6		
補巻時最大荷重	54.6	46.7	35.0	45.6	35.0	29.9		40.9	35.0	29.3		

注) カウンタウエイト 0t、アウトリガ張出幅 2.55m(前後のみ)

## ■ T 性能

### ● ブーム

(単位：t)

性能ブロック	1	9	1	9	10	2	1	10	11	2	1	
性能番号	1	23	2	24	25	12	3	26	27	13	4	
ブーム長さ(m)	11.1		14.8		18.5				22.1			
作業半径(m)	11.1		14.8		18.5				22.1			
2.5	29.0											
3.0	19.2	18.4	21.0	17.7	18.7	21.8	22.0					
3.5	13.9	13.1	15.4	12.5	13.4	16.1	16.2	12.9	13.9	16.3	16.9	
4.0	10.5	9.8	11.9	9.2	10.0	12.5	12.6	9.5	10.5	12.6	13.3	
4.5	8.1	7.5	9.4	7.0	7.7	10.0	10.1	7.3	8.2	10.1	10.7	
5.0	6.4	5.8	7.7	5.3	6.0	8.2	8.3	5.6	6.5	8.3	8.9	
6.0	4.1	3.5	5.2	3.1	3.7	5.7	5.8	3.3	4.1	5.8	6.3	
7.0	2.6	2.0	3.6		2.2	4.1	4.2		2.6	4.2	4.7	
8.0	1.5	1.0	2.5			3.0	3.1			3.1	3.5	
9.0			1.7			2.2	2.2			2.2	2.7	
10.0			1.1			1.5	1.6			1.6	2.0	
11.0						1.0	1.1			1.1	1.5	
12.0											1.1	
ピン無最大荷重	21.5	18.4	21.0	17.6	18.7	21.8	21.8	15.4	12.9	13.9	16.3	
θ(°)	0~82		50~82		6~82		66~82		63~82		42~82	
伸長状態 (伸長割合%)												
伸縮ブーム1	0	46	0	92	46	0	0	92	46	0	0	
伸縮ブーム2	0	0	0	0	46	0	0	46	46	0	0	
伸縮ブーム3	0	0	0	0	0	0	0	46	46	46	0	
伸縮ブーム4	0	0	0	0	0	46	0	0	46	0	46	
伸縮ブーム5	0	0	46	0	0	46	92	0	0	46	92	
標準フック	55t	55t		55t	55t		55t	55t	19t		55t	
フック質量	650kg	650kg		650kg	650kg		650kg	650kg	300kg		650kg	
主巻時標準巻掛本数	6	4		4		5		3		4		
補巻時標準巻掛本数	6	4		4		5		3		4		
補巻時最大荷重	29.0	18.4	21.0	17.7	18.7	21.8	22.0	12.9	13.9	16.3	16.9	

注) カウンタウエイト 0t、アウトリガ張出幅 2.55m

## ■ 定格総荷重表注意事項

◆ 定格総荷重表の性能区分A~Tは、下表のとおりです。

アウトリガ張出幅	カウンタウエイト					
	25t	21t	15t	9t	5t	0t
7.2m	A	B	C	D	E	F
6.0m	G	H	I	J	K	L
5.0m	M	N	O	P	Q	R
2.55m						S、T

※同じ性能区分・ブーム長さでも、ブームの伸長状態によって定格総荷重が異なります。  
 ※S、T性能は22.1mブームまでで、作業領域は図のようになります。

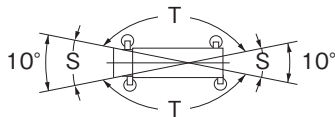

- ◆ 定格総荷重は、つり具質量とフック質量 (55 tフック：650kg、18 tフック：300kg、5.6 tフック：150kg) を含んだ値を示します。
- ◆ 定格総荷重は、ブームのたわみを含んだ実際の作業半径に基づいています。
- ◆ 定格総荷重表中の標準巻掛本数より少ない本数で使用する場合、最大荷重の上限は下表のとおりです。

巻掛本数	11本	10本	9本	8本	7本	6本	5本	4本	3本	2本	1本
最大荷重	54.6t	50.2t	45.6t	40.9t	36.1t	31.3t	26.3t	21.3t	16.1t	11.0t	5.6t

- ◆ シングルトップ使用時の巻掛本数は1本(5.6 tフック使用)で、定格総荷重はブームの定格総荷重からブームに取り付けられているフックの質量を差し引いた値とし、かつ上限は5.6 tです。
- ◆ 定格総荷重はアウトリガを水平堅土上に設置したときの値です。
- ◆ 定格総荷重表は、風による影響を含んでいません。瞬間最大風速が10m/s以上の風速では、クレーン作業を中止してください。

### 定格総荷重表中の線、および用語説明

- ◆ 太線より上側はクレーンの強度に、下側はクレーンの安定に基づいています。
- ◆ 「ピン無最大荷重」は、Bピン(ブーム固定ピン)を挿入していないときの定格総荷重の上限を示します。
- ◆ 「θ(°)」は、無負荷状態で作業可能なブーム起伏角度範囲を示します。
- ◆ 「主巻時・標準巻掛本数」は、主巻使用時の標準巻掛本数を示します。
- ◆ 「補巻時・標準巻掛本数」は、補巻使用時の標準巻掛本数を示し、主巻よりもワイヤロープ長さが短いため、巻掛本数が少なくなる場合があります。
- ◆ 「補巻時・最大荷重」は補巻使用時の定格総荷重の上限を示します。

# TADANO ATF100G-4

■作業範囲図

● 33.2mブーム+油圧チルトジブ

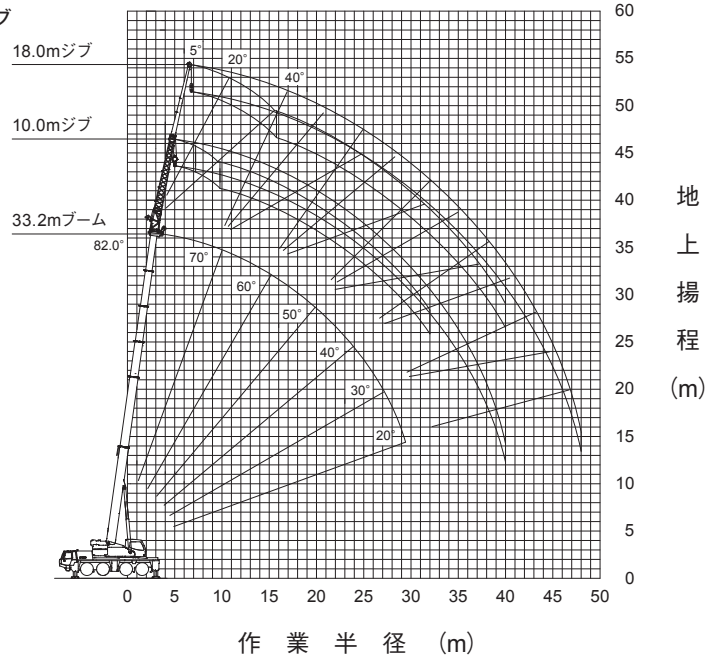

● 47.9mブーム+油圧チルトジブ

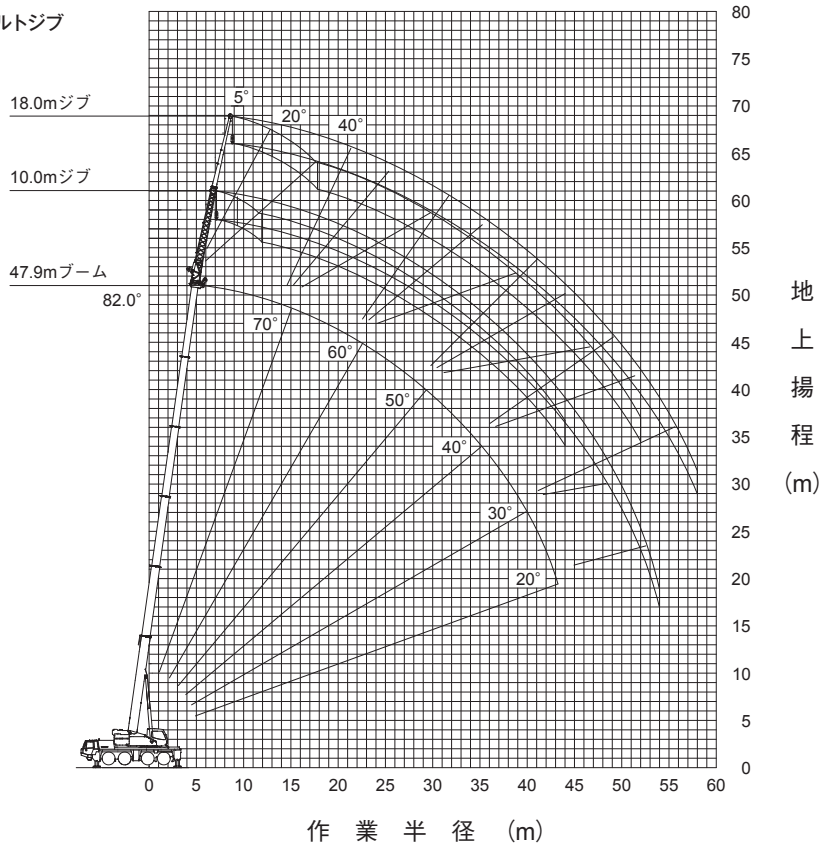

(注) 1. 上図はブームおよびジブのたわみを含んでいません。  
2. A性能を図示しています。

縮尺 1/800

# TADANO ATF100G-4

## ■作業範囲図

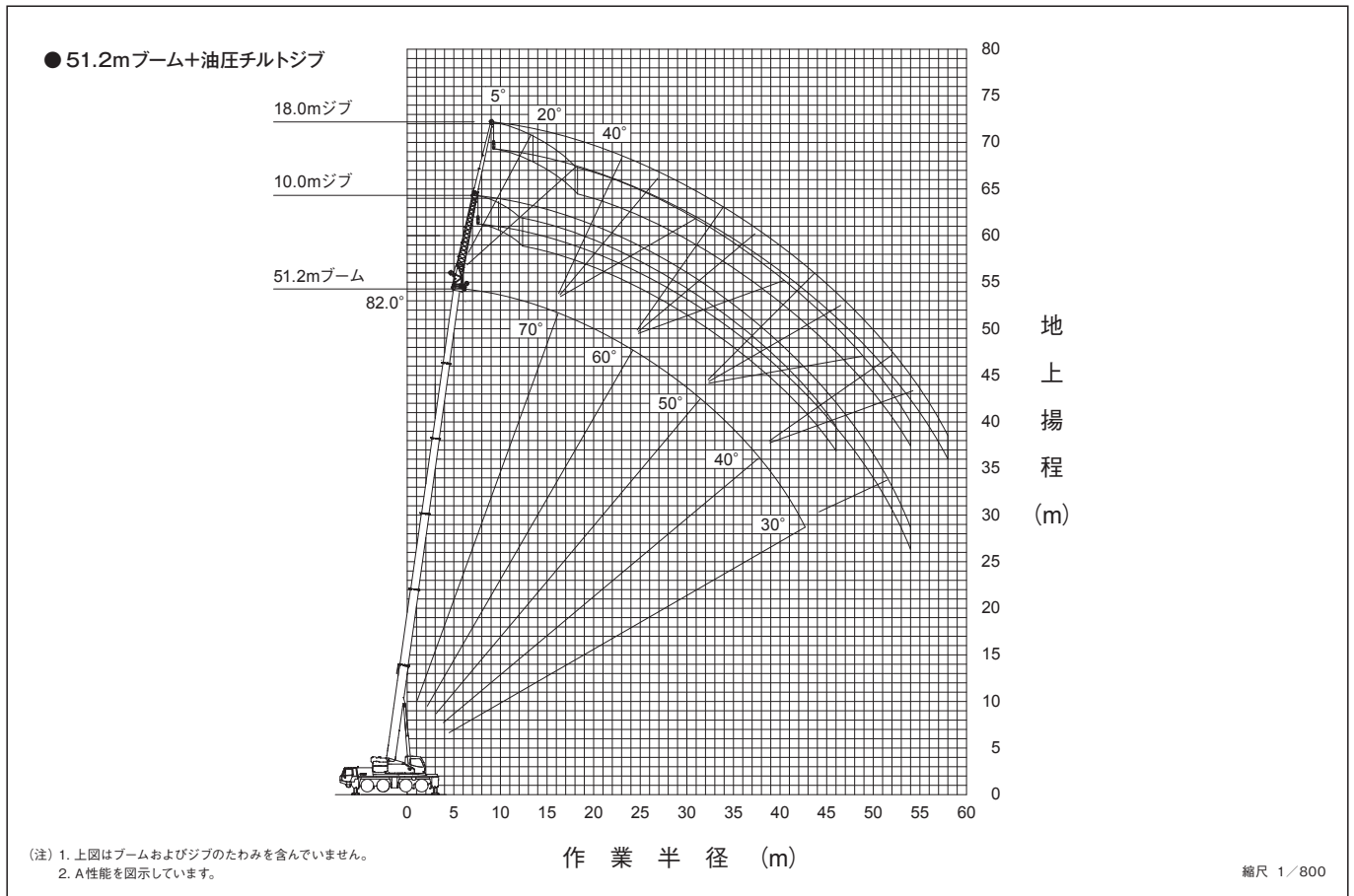

## ■定格総荷重表注意事項

◆ 定格総荷重表の性能区分A～Qは、下表のとおりです。

アウトリガ張出幅	カウンタウエイト				
	25t	21t	15t	9t	5t
7.2m	A	B	C	D	E
6.0m	G	H	I	J	K
5.0m	M	N	O	P	Q

◆ 定格総荷重は、つり具質量とフック質量 (18 tフック : 300 kg、5.6 tフック : 150 kg) を含んだ値を示します。

◆ 定格総荷重は、ブームとジブのたわみを含んだ実際の作業半径に基づいています。

◆ 各ブーム長さにおける各伸縮ブームの伸長状態 (伸長割合 %) は、下表のとおりです。

ブーム長さ	33.2m	47.9m	51.2m
伸縮ブーム 1	92	92	100
伸縮ブーム 2	46	92	100
伸縮ブーム 3	46	92	100
伸縮ブーム 4	46	92	100
伸縮ブーム 5	46	92	100

◆ 定格総荷重表中の標準巻掛本数よりも少ない本数で使用する場合、最大荷重の上限は下表のとおりです。

巻掛本数	1本
最大荷重	5.6t

◆ 定格総荷重はアウトリガを水平堅土上に設置したときの値です。

◆ 定格総荷重表は、風による影響を含んでいません。瞬間最大風速が10m/s以上の風速では、クレーン作業を中止してください。

### 定格総荷重表中の線、および用語説明

◆ 太線より上側はクレーンの強度に、下側はクレーンの安定に基づいています。

◆ 「オフセット」はブームの中心線とジブの中心線とのなす角度を示します。

◆ 「 $\theta$ (°)」は、無負荷状態で作動可能なブーム起伏角度範囲を示します。

# TADANO ATF100G-4

## ■ A 性能

● 33.2mブーム+油圧チルトジブ (単位:t)

ジブ長さ(m)	10.0						18.0					
	オフセット			オフセット			オフセット			オフセット		
	5°	20°	40°	5°	20°	40°	5°	20°	40°	5°	20°	40°
8.0	10.1											
9.0	10.1											
10.0	10.1	8.9			4.2							
11.0	9.7	8.5			4.2							
12.0	9.3	8.1			4.2							
14.0	8.6	7.5	6.6	4.2	4.2							
16.0	8.0	7.0	6.2	4.2	4.2							
18.0	7.4	6.6	5.9	4.2	4.1							
20.0	6.9	6.2	5.6	4.2	3.9	3.2						
22.0	6.5	5.9	5.4	4.2	3.8	3.0						
24.0	6.1	5.6	5.1	4.2	3.6	2.9						
26.0	5.8	5.3	5.0	4.0	3.5	2.9						
28.0	5.4	5.1	4.8	3.9	3.4	2.8						
30.0	4.7	4.9	4.6	3.7	3.2	2.7						
32.0	4.1	4.3	4.4	3.6	3.1	2.6						
34.0	3.6	3.7		3.5	3.0	2.6						
36.0	3.1	3.2		3.3	2.9	2.5						
38.0	2.7	2.8		3.1	2.8	2.5						
40.0	2.4			2.9	2.7	2.5						
42.0				2.5	2.6							
44.0				2.2	2.4							
46.0				2.0	2.1							
48.0				1.7								
θ(°)	15~82	27~82	46~82	18~82	29~82	47~82						
標準フック	18t			5.6t								
フック重量	300kg			150kg								
標準巻掛本数	2			1								

注) カウンタウエイト 25t、アウトリガ張出幅 7.2m

● 47.9mブーム+油圧チルトジブ (単位:t)

ジブ長さ(m)	10.0						18.0					
	オフセット			オフセット			オフセット			オフセット		
	5°	20°	40°	5°	20°	40°	5°	20°	40°	5°	20°	40°
11.0	4.9											
12.0	4.9											
14.0	4.9					2.9						
16.0	4.9	4.9				2.9						
18.0	4.9	4.7	4.4	2.9	2.9							
20.0	4.8	4.4	4.2	2.9	2.9							
22.0	4.5	4.2	4.0	2.9	2.9							
24.0	4.3	4.0	3.8	2.9	2.9							
26.0	4.1	3.9	3.7	2.9	2.9	2.7						
28.0	3.9	3.7	3.5	2.9	2.8	2.6						
30.0	3.7	3.6	3.4	2.9	2.6	2.5						
32.0	3.5	3.4	3.3	2.7	2.5	2.4						
34.0	3.3	3.2	3.2	2.6	2.5	2.3						
36.0	3.1	3.1	3.1	2.5	2.4	2.3						
38.0	2.8	2.9	2.9	2.5	2.3	2.2						
40.0	2.5	2.6	2.7	2.4	2.2	2.1						
42.0	2.1	2.3	2.4	2.3	2.2	2.1						
44.0	1.8	2.0	2.0	2.1	2.1	2.0						
46.0	1.6	1.7		1.9	2.0	2.0						
48.0	1.3	1.4		1.6	1.8	1.9						
50.0	1.0	1.1		1.4	1.6	1.7						
52.0	0.8	0.8		1.1	1.3	1.4						
54.0	0.6			0.9	1.1							
56.0				0.7	0.8							
58.0				0.5	0.6							
θ(°)	20~82	28~82	46~82	31~82	34~82	47~82						
標準フック	5.6t			5.6t								
フック重量	150kg			150kg								
標準巻掛本数	1			1								

注) カウンタウエイト 25t、アウトリガ張出幅 7.2m

● 51.2mブーム+油圧チルトジブ (単位:t)

ジブ長さ(m)	10.0						18.0					
	オフセット			オフセット			オフセット			オフセット		
	5°	20°	40°	5°	20°	40°	5°	20°	40°	5°	20°	40°
12.0	4.4											
14.0	4.4											
16.0	4.4	4.4				2.7						
18.0	4.4	4.4				2.7						
20.0	4.4	4.1	3.9	2.7	2.7							
22.0	4.2	4.0	3.7	2.7	2.7							
24.0	4.0	3.8	3.6	2.7	2.7							
26.0	3.8	3.6	3.5	2.7	2.7	2.6						
28.0	3.6	3.5	3.3	2.7	2.6	2.5						
30.0	3.4	3.3	3.2	2.7	2.5	2.4						
32.0	3.2	3.1	3.1	2.6	2.4	2.3						
34.0	3.0	3.0	3.0	2.5	2.3	2.2						
36.0	2.8	2.9	2.8	2.4	2.2	2.1						
38.0	2.6	2.7	2.7	2.3	2.2	2.1						
40.0	2.4	2.4	2.5	2.2	2.1	2.0						
42.0	2.1	2.2	2.3	2.1	2.0	1.9						
44.0	1.8	1.9	2.0	2.0	2.0	1.9						
46.0	1.5	1.6	1.7	1.8	1.9	1.8						
48.0	1.2	1.3		1.5	1.7	1.8						
50.0	1.0	1.1		1.3	1.5	1.6						
52.0	0.7	0.8		1.1	1.3	1.4						
54.0	0.5	0.6		0.8	1.0	1.2						
56.0				0.6	0.8							
58.0				0.6	0.8							
θ(°)	29~82	30~82	47~82	41~82	40~82	49~82						
標準フック	5.6t			5.6t								
フック重量	150kg			150kg								
標準巻掛本数	1			1								

注) カウンタウエイト 25t、アウトリガ張出幅 7.2m

## ■ B 性能

● 33.2mブーム+油圧チルトジブ (単位:t)

ジブ長さ(m)	10.0						18.0					
	オフセット			オフセット			オフセット			オフセット		
	5°	20°	40°	5°	20°	40°	5°	20°	40°	5°	20°	40°
8.0	10.1											
9.0	10.1											
10.0	10.1	8.9			4.2							
11.0	9.7	8.5			4.2							
12.0	9.3	8.1			4.2							
14.0	8.6	7.5	6.6	4.2	4.2							
16.0	8.0	7.0	6.2	4.2	4.2							
18.0	7.4	6.6	5.9	4.2	4.1							
20.0	6.9	6.2	5.6	4.2	3.9	3.2						
22.0	6.5	5.9	5.4	4.2	3.8	3.0						
24.0	6.1	5.6	5.1	4.2	3.6	2.9						
26.0	5.4	5.3	5.0	4.0	3.5	2.9						
28.0	4.7	4.9	4.8	3.9	3.4	2.8						
30.0	4.0	4.2	4.4	3.7	3.2	2.7						
32.0	3.5	3.6	3.8	3.6	3.1	2.6						
34.0	3.0	3.1		3.5	3.0	2.6						
36.0	2.5	2.6		3.1	2.9	2.5						
38.0	2.2	2.2		2.7	2.8	2.5						
40.0	1.8			2.4	2.6	2.5						
42.0				2.0	2.2							
44.0				1.8	1.9							
46.0				1.5	1.6							
48.0				1.3								
θ(°)	15~82	27~82	46~82	18~82	29~82	47~82						
標準フック	18t			5.6t								
フック重量	300kg			150kg								
標準巻掛本数	2			1								

注) カウンタウエイト 21t、アウトリガ張出幅 7.2m

● 47.9mブーム+油圧チルトジブ (単位:t)

ジブ長さ(m)	10.0						18.0					
	オフセット			オフセット			オフセット			オフセット		
	5°	20°	40°	5°	20°	40°	5°	20°	40°	5°	20°	40°
11.0	4.9											
12.0	4.9											
14.0	4.9					2.9						
16.0	4.9	4.9				2.9						
18.0	4.9	4.7	4.4	2.9	2.9							
20.0	4.8	4.4	4.2	2.9	2.9							
22.0	4.5	4.2	4.0	2.9	2.9							
24.0	4.3	4.0	3.8	2.9	2.9							
26.0	4.1	3.9	3.7	2.9	2.9	2.7						
28.0	3.9	3.7	3.5	2.9	2.8	2.6						
30.0	3.7	3.6	3.4	2.9	2.6	2.5						
32.0	3.5	3.4	3.3	2.7	2.5	2.4						
34.0	3.1	3.2	3.2	2.6	2.5	2.3						
36.0	2.7	2.8	3.0	2.5	2.4	2.3						
38.0	2.3	2.4	2.6	2.5	2.3	2.2						
40.0	1.9	2.1	2.2	2.3	2.2	2.1						
42.0	1.6	1.8	1.9	1.9	2.2	2.1						
44.0	1.4	1.5	1.6	1.7	1.9	2.0						
46.0	1.1	1.2		1.4	1.6	1.8						
48.0	0.8	0.9		1.2	1.4	1.5						
50.0	0.6	0.7		1.0	1.1	1.3						

# TADANO ATF100G-4

## ■ C性能

### ● 33.2mブーム+油圧チルトジブ (単位: t)

ジブ長さ(m)	10.0						18.0					
	オフセット			オフセット			オフセット			オフセット		
	5°	20°	40°	5°	20°	40°	5°	20°	40°	5°	20°	40°
8.0	10.1											
9.0	10.1											
10.0	10.1	8.9			4.2							
11.0	9.7	8.5			4.2							
12.0	9.3	8.1			4.2							
14.0	8.6	7.5	6.6	4.2	4.2							
16.0	8.0	7.0	6.2	4.2	4.2							
18.0	7.4	6.6	5.9	4.2	4.1							
20.0	6.9	6.2	5.6	4.2	3.9	3.2						
22.0	5.9	5.9	5.4	4.2	3.8	3.0						
24.0	5.0	5.3	5.1	4.2	3.6	2.9						
26.0	4.2	4.4	4.7	4.0	3.5	2.9						
28.0	3.5	3.7	3.9	3.9	3.4	2.8						
30.0	2.9	3.1	3.3	3.5	3.2	2.7						
32.0	2.4	2.6	2.7	3.0	3.1	2.6						
34.0	2.0	2.2		2.6	2.9	2.6						
36.0	1.7	1.8		2.2	2.5	2.5						
38.0	1.3	1.4		1.9	2.1	2.3						
40.0	1.1			1.6	1.8	1.9						
42.0				1.3	1.5							
44.0				1.0	1.2							
46.0				0.8	0.9							
48.0				0.6								
θ(°)	15~82	27~82	46~82	18~82	29~82	47~82						
標準フック	18t			5.6t								
フック重量	300kg			150kg								
標準巻掛本数	2			1								

注) カウンタウエイト 15t、アウトリガ張出幅 7.2m

### ● 47.9mブーム+油圧チルトジブ (単位: t)

ジブ長さ(m)	10.0						18.0					
	オフセット			オフセット			オフセット			オフセット		
	5°	20°	40°	5°	20°	40°	5°	20°	40°	5°	20°	40°
11.0	4.9											
12.0	4.9											
14.0	4.9					2.9						
16.0	4.9	4.9				2.9						
18.0	4.9	4.7	4.4	2.9								
20.0	4.8	4.4	4.2	2.9	2.9							
22.0	4.5	4.2	4.0	2.9	2.9							
24.0	4.3	4.0	3.8	2.9	2.9							
26.0	4.1	3.9	3.7	2.9	2.9	2.7						
28.0	3.6	3.7	3.5	2.9	2.8	2.6						
30.0	3.1	3.3	3.4	2.9	2.6	2.5						
32.0	2.6	2.8	3.0	2.7	2.5	2.4						
34.0	2.2	2.4	2.5	2.5	2.5	2.3						
36.0	1.8	2.0	2.1	2.1	2.4	2.3						
38.0	1.4	1.6	1.8	1.8	2.1	2.2						
40.0	1.2	1.3	1.4	1.5	1.7	2.0						
42.0	0.9	1.0	1.1	1.2	1.4	1.7						
44.0	0.6	0.8	0.8	0.9	1.2	1.4						
46.0		0.5		0.7	0.9	1.1						
48.0				0.5	0.7	0.9						
50.0					0.5	0.6						
θ(°)	42~82	41~82	46~82	47~82	48~82	50~82						
標準フック	5.6t			5.6t								
フック重量	150kg			150kg								
標準巻掛本数	1			1								

注) カウンタウエイト 15t、アウトリガ張出幅 7.2m

### ● 51.2mブーム+油圧チルトジブ (単位: t)

ジブ長さ(m)	10.0						18.0					
	オフセット			オフセット			オフセット			オフセット		
	5°	20°	40°	5°	20°	40°	5°	20°	40°	5°	20°	40°
12.0	4.4											
14.0	4.4											
16.0	4.4	4.4				2.7						
18.0	4.4	4.4				2.7						
20.0	4.4	4.1	3.9	2.7								
22.0	4.2	4.0	3.7	2.7	2.7							
24.0	4.0	3.8	3.6	2.7	2.7							
26.0	3.8	3.6	3.5	2.7	2.7	2.6						
28.0	3.6	3.5	3.3	2.7	2.6	2.5						
30.0	3.0	3.3	3.2	2.7	2.5	2.4						
32.0	2.5	2.8	3.0	2.6	2.4	2.3						
34.0	2.1	2.3	2.5	2.4	2.3	2.2						
36.0	1.7	1.9	2.1	2.0	2.2	2.1						
38.0	1.4	1.6	1.7	1.7	2.0	2.1						
40.0	1.1	1.3	1.4	1.4	1.7	2.0						
42.0	0.8	1.0	1.1	1.1	1.4	1.7						
44.0	0.6	0.7	0.8	0.9	1.1	1.4						
46.0			0.6	0.7	0.9	1.1						
48.0					0.7	0.9						
50.0						0.6						
θ(°)	46~82	48~82	47~82	53~82	54~82	54~82						
標準フック	5.6t			5.6t								
フック重量	150kg			150kg								
標準巻掛本数	1			1								

注) カウンタウエイト 15t、アウトリガ張出幅 7.2m

## ■ D性能

### ● 33.2mブーム+油圧チルトジブ (単位: t)

ジブ長さ(m)	10.0						18.0					
	オフセット			オフセット			オフセット			オフセット		
	5°	20°	40°	5°	20°	40°	5°	20°	40°	5°	20°	40°
8.0	10.1											
9.0	10.1											
10.0	10.1	8.9			4.2							
11.0	9.7	8.5			4.2							
12.0	9.3	8.1			4.2							
14.0	8.6	7.5	6.6	4.2	4.2							
16.0	8.0	7.0	6.2	4.2	4.2							
18.0	6.6	6.6	5.9	4.2	4.1							
20.0	5.3	5.8	5.6	4.2	3.9	3.2						
22.0	4.3	4.7	5.1	4.2	3.8	3.0						
24.0	3.5	3.8	4.2	4.2	3.6	2.9						
26.0	2.8	3.1	3.4	3.5	3.5	2.9						
28.0	2.3	2.5	2.7	2.9	3.4	2.8						
30.0	1.8	2.0	2.2	2.4	2.8	2.7						
32.0	1.4	1.6	1.7	2.0	2.3	2.6						
34.0	1.1	1.2		1.6	1.9	2.3						
36.0	0.7	0.9		1.3	1.6	1.8						
38.0	0.5	0.6		1.0	1.2	1.5						
40.0				0.8	1.0	1.1						
42.0				0.5	0.7							
44.0					0.5							
θ(°)	24~82	27~82	46~82	36~82	35~82	47~82						
標準フック	18t			5.6t								
フック重量	300kg			150kg								
標準巻掛本数	2			1								

注) カウンタウエイト 9t、アウトリガ張出幅 7.2m

### ● 47.9mブーム+油圧チルトジブ (単位: t)

ジブ長さ(m)	10.0						18.0					
	オフセット			オフセット			オフセット			オフセット		
	5°	20°	40°	5°	20°	40°	5°	20°	40°	5°	20°	40°
11.0	4.9											
12.0	4.9											
14.0	4.9					2.9						
16.0	4.9	4.9				2.9						
18.0	4.9	4.7	4.4	2.9								
20.0	4.8	4.4	4.2	2.9	2.9							
22.0	4.5	4.2	4.0	2.9	2.9							
24.0	3.7	4.0	3.8	2.9	2.9	2.7						
26.0	3.0	3.3	3.7	2.9	2.9	2.6						
28.0	2.4	2.7	3.0	2.8	2.8	2.6						
30.0	2.0	2.2	2.5	2.3	2.6	2.5						
32.0	1.5	1.8	2.0	1.9	2.3	2.4						
34.0	1.2	1.4	1.6	1.5	1.9	2.3						
36.0	0.9	1.1	1.2	1.2	1.5	1.9						
38.0	0.6	0.8	0.9	0.9	1.2	1.5						
40.0		0.5	0.6	0.7	0.9	1.2						
42.0					0.7	0.9						
44.0					0.5	0.7						
θ(°)	51~82	50~82	52~82	57~82	56~82	59~82						
標準フック	5.6t			5.6t								
フック重量	150kg			150kg								
標準巻掛本数	1			1								

注) カウンタウエイト 9t、アウトリガ張出幅 7.2m

### ● 51.2mブーム+油圧チルトジブ (単位: t)

ジブ長さ(m)	10.0						18.0					
	オフセット			オフセット			オフセット			オフセット		
	5°	20°	40°	5°	20°	40°	5°	20°	40°	5°	20°	40°
12.0	4.4											
14.0	4.4											
16.0	4.4	4.4				2.7						
18.0	4.4	4.4				2.7						
20.0	4.4	4.1	3.9	2.7								
22.0	4.2	4.0	3.7	2.7	2.7							
24.0	3.8	3.6	3.6	2.7	2.7	2.6						
26.0												

# TADANO ATF100G-4

## ■ G性能

### ● 33.2mブーム+油圧チルトジブ (単位:t)

ジブ長さ(m)	10.0			18.0		
	オフセット			オフセット		
	5°	20°	40°	5°	20°	40°
8.0	10.1					
9.0	10.1					
10.0	10.1	8.9		4.2		
11.0	9.7	8.5		4.2		
12.0	9.3	8.1		4.2		
14.0	8.6	7.5	6.6	4.2		
16.0	8.0	7.0	6.2	4.2	4.2	
18.0	7.4	6.6	5.9	4.2	4.1	
20.0	6.9	6.2	5.6	4.2	3.9	3.2
22.0	6.5	5.9	5.4	4.2	3.8	3.0
24.0	5.8	5.6	5.1	4.2	3.6	2.9
26.0	4.9	5.2	5.0	4.0	3.5	2.9
28.0	4.2	4.4	4.7	3.9	3.4	2.8
30.0	3.6	3.8	4.0	3.7	3.2	2.7
32.0	3.1	3.2	3.4	3.6	3.1	2.6
34.0	2.6	2.8		3.2	3.0	2.6
36.0	2.2	2.3		2.8	2.9	2.5
38.0	1.9	1.9		2.4	2.6	2.5
40.0	1.6			2.1	2.3	2.5
42.0				1.8	2.0	
44.0				1.5	1.7	
46.0				1.3	1.4	
48.0				1.1		
θ(°)	15~82	27~82	46~82	18~82	29~82	47~82
標準フック	18t			5.6t		
フック重量	300kg			150kg		
標準巻掛本数	2			1		

注) カウンタウエイト 25t、アウトリガ張出幅 6.0m

### ● 47.9mブーム+油圧チルトジブ (単位:t)

ジブ長さ(m)	10.0			18.0		
	オフセット			オフセット		
	5°	20°	40°	5°	20°	40°
11.0	4.9					
12.0	4.9					
14.0	4.9			2.9		
16.0	4.9	4.9		2.9		
18.0	4.9	4.7	4.4	2.9		
20.0	4.8	4.4	4.2	2.9	2.9	
22.0	4.5	4.2	4.0	2.9	2.9	
24.0	4.3	4.0	3.8	2.9	2.9	
26.0	4.1	3.9	3.7	2.9	2.9	2.7
28.0	3.9	3.7	3.5	2.9	2.8	2.6
30.0	3.7	3.6	3.4	2.9	2.6	2.5
32.0	3.2	3.4	3.3	2.7	2.5	2.4
34.0	2.8	3.0	3.1	2.6	2.5	2.3
36.0	2.3	2.5	2.7	2.5	2.4	2.3
38.0	2.0	2.1	2.3	2.3	2.3	2.2
40.0	1.7	1.8	1.9	2.0	2.2	2.1
42.0	1.4	1.5	1.6	1.7	1.9	2.1
44.0	1.1	1.2	1.3	1.4	1.7	1.9
46.0	0.8	0.9		1.2	1.4	1.6
48.0	0.6	0.7		0.9	1.2	1.3
50.0				0.7	0.9	1.1
52.0				0.5	0.7	0.8
θ(°)	35~82	37~82	46~82	42~82	45~82	47~82
標準フック	5.6t			5.6t		
フック重量	150kg			150kg		
標準巻掛本数	1			1		

注) カウンタウエイト 25t、アウトリガ張出幅 6.0m

### ● 51.2mブーム+油圧チルトジブ (単位:t)

ジブ長さ(m)	10.0			18.0		
	オフセット			オフセット		
	5°	20°	40°	5°	20°	40°
12.0	4.4					
14.0	4.4					
16.0	4.4	4.4		2.7		
18.0	4.4	4.4		2.7		
20.0	4.4	4.1	3.9	2.7		
22.0	4.2	4.0	3.7	2.7	2.7	
24.0	4.0	3.8	3.6	2.7	2.7	
26.0	3.8	3.6	3.5	2.7	2.7	2.6
28.0	3.6	3.5	3.3	2.7	2.6	2.5
30.0	3.4	3.3	3.2	2.7	2.5	2.4
32.0	3.2	3.1	3.1	2.6	2.4	2.3
34.0	2.7	2.9	3.0	2.5	2.3	2.2
36.0	2.3	2.5	2.7	2.4	2.2	2.1
38.0	1.9	2.1	2.3	2.2	2.2	2.1
40.0	1.6	1.8	1.9	1.9	2.1	2.0
42.0	1.3	1.5	1.6	1.6	1.9	1.9
44.0	1.0	1.2	1.3	1.4	1.6	1.9
46.0	0.8	0.9	1.0	1.1	1.3	1.6
48.0	0.5	0.6		0.8	1.1	1.3
50.0				0.6	0.8	1.1
52.0					0.6	0.8
54.0						0.5
θ(°)	40~82	42~82	47~82	49~82	49~82	48~82
標準フック	5.6t			5.6t		
フック重量	150kg			150kg		
標準巻掛本数	1			1		

注) カウンタウエイト 25t、アウトリガ張出幅 6.0m

## ■ H性能

### ● 33.2mブーム+油圧チルトジブ (単位:t)

ジブ長さ(m)	10.0			18.0		
	オフセット			オフセット		
	5°	20°	40°	5°	20°	40°
8.0	10.1					
9.0	10.1					
10.0	10.1	8.9		4.2		
11.0	9.7	8.5		4.2		
12.0	9.3	8.1		4.2		
14.0	8.6	7.5	6.6	4.2		
16.0	8.0	7.0	6.2	4.2	4.2	
18.0	7.4	6.6	5.9	4.2	4.1	
20.0	6.9	6.2	5.6	4.2	3.9	3.2
22.0	5.9	5.9	5.4	4.2	3.8	3.0
24.0	4.9	5.2	5.1	4.2	3.6	2.9
26.0	4.1	4.4	4.7	4.0	3.5	2.9
28.0	3.5	3.7	3.9	3.9	3.4	2.8
30.0	2.9	3.1	3.3	3.5	3.2	2.7
32.0	2.4	2.6	2.7	3.0	3.1	2.6
34.0	2.0	2.2		2.6	2.9	2.6
36.0	1.7	1.8		2.2	2.5	2.5
38.0	1.4	1.4		1.9	2.1	2.4
40.0	1.1			1.6	1.8	2.0
42.0				1.3	1.5	
44.0				1.1	1.2	
46.0				0.9	1.0	
48.0				0.6		
θ(°)	15~82	27~82	46~82	18~82	29~82	47~82
標準フック	18t			5.6t		
フック重量	300kg			150kg		
標準巻掛本数	2			1		

注) カウンタウエイト 21t、アウトリガ張出幅 6.0m

### ● 47.9mブーム+油圧チルトジブ (単位:t)

ジブ長さ(m)	10.0			18.0		
	オフセット			オフセット		
	5°	20°	40°	5°	20°	40°
11.0	4.9					
12.0	4.9					
14.0	4.9			2.9		
16.0	4.9	4.9		2.9		
18.0	4.9	4.7	4.4	2.9		
20.0	4.8	4.4	4.2	2.9	2.9	
22.0	4.5	4.2	4.0	2.9	2.9	
24.0	4.3	4.0	3.8	2.9	2.9	
26.0	4.1	3.9	3.7	2.9	2.9	2.7
28.0	3.6	3.7	3.5	2.9	2.8	2.6
30.0	3.1	3.3	3.4	2.9	2.6	2.5
32.0	2.6	2.8	3.0	2.7	2.5	2.4
34.0	2.2	2.4	2.6	2.5	2.5	2.3
36.0	1.8	2.0	2.1	2.1	2.4	2.3
38.0	1.5	1.6	1.8	1.8	2.1	2.2
40.0	1.2	1.3	1.4	1.5	1.8	2.1
42.0	0.9	1.0	1.1	1.2	1.5	1.7
44.0	0.6	0.7	0.9	1.0	1.2	1.4
46.0		0.5		0.7	1.0	1.2
48.0				0.5	0.7	0.9
50.0					0.5	0.7
θ(°)	42~82	41~82	46~82	47~82	48~82	50~82
標準フック	5.6t			5.6t		
フック重量	150kg			150kg		
標準巻掛本数	1			1		

注) カウンタウエイト 21t、アウトリガ張出幅 6.0m

### ● 51.2mブーム+油圧チルトジブ (単位:t)

ジブ長さ(m)	10.0			18.0		
	オフセット			オフセット		
	5°	20°	40°	5°	20°	40°
12.0	4.4					
14.0	4.4					
16.0	4.4	4.4		2.7		
18.0	4.4	4.4		2.7		
20.0	4.4	4.1	3.9	2.7		
22.0	4.2	4.0	3.7	2.7	2.7	
24.0	4.0	3.8	3.6	2.7	2.7	
26.0	3.8	3.6	3.5	2.7	2.7	2.6
28.0	3.6	3.5	3.3	2.7	2.6	2.5
30.0	3.0	3.3	3.2	2.7	2.5	2.4
32.0	2.5	2.8	3.0	2.6	2.4	2.3
34.0	2.1	2.3	2.5	2.4	2.3	2.2
36.0	1.7	1.9	2.1	2.0	2.2	2.1
38.0	1.4	1.6	1.7	1.7	2.0	2.1
40.0	1.1	1.3	1.4	1.4	1.7	2.0
42.0	0.8	1.0	1.1	1.2	1.4	1.7
44.0	0.5	0.7	0.8	0.9	1.2	1.4
46.0			0.5	0.6	0.9	1.1
48.0					0.7	0.9
50.0						0.6
θ(°)	46~82	48~82	47~82	53~82	54~82	54~82
標準フック	5.6t			5.6t		
フック重量	150kg			150kg		
標準巻掛本数	1			1		

注) カウンタウエイト 21t、アウトリガ張出幅 6.0m

# TADANO ATF100G-4

## I 性能

● 33.2m ブーム+油圧チルトジブ (単位:t)

ジブ長さ(m)	10.0						18.0					
	オフセット			オフセット			オフセット			オフセット		
	5°	20°	40°	5°	20°	40°	5°	20°	40°	5°	20°	40°
8.0	10.1											
9.0	10.1											
10.0	10.1	8.9			4.2							
11.0	9.7	8.5			4.2							
12.0	9.3	8.1			4.2							
14.0	8.6	7.5	6.6	4.2	4.2							
16.0	8.0	7.0	6.2	4.2	4.2							
18.0	6.7	6.6	5.9	4.2	4.1							
20.0	5.4	5.9	5.6	4.2	3.9	3.2						
22.0	4.4	4.8	5.2	4.2	3.8	3.0						
24.0	3.6	3.9	4.3	4.2	3.6	2.9						
26.0	3.0	3.2	3.5	3.6	3.5	2.9						
28.0	2.4	2.6	2.9	3.0	3.4	2.8						
30.0	1.9	2.1	2.3	2.5	2.9	2.7						
32.0	1.5	1.7	1.8	2.1	2.5	2.6						
34.0	1.2	1.3		1.7	2.1	2.4						
36.0	0.9	1.0		1.4	1.7	2.0						
38.0	0.6	0.7		1.1	1.4	1.6						
40.0				0.9	1.1	1.2						
42.0				0.6	0.8							
44.0					0.6							
θ(°)	24~82	27~82	46~82	36~82	35~82	47~82						
標準フック	18t			5.6t								
フック重量	300kg			150kg								
標準巻掛本数	2			1								

注) カウンタウエイト 15t、アウトリガ張出幅 6.0m

● 47.9m ブーム+油圧チルトジブ (単位:t)

ジブ長さ(m)	10.0						18.0					
	オフセット			オフセット			オフセット			オフセット		
	5°	20°	40°	5°	20°	40°	5°	20°	40°	5°	20°	40°
11.0	4.9											
12.0	4.9											
14.0	4.9					2.9						
16.0	4.9	4.9				2.9						
18.0	4.9	4.7	4.4	2.9								
20.0	4.8	4.4	4.2	2.9	2.9							
22.0	4.5	4.2	4.0	2.9	2.9							
24.0	3.8	4.0	3.8	2.9	2.9							
26.0	3.1	3.4	3.7	2.9	2.9	2.7						
28.0	2.6	2.8	3.1	2.9	2.8	2.6						
30.0	2.1	2.3	2.6	2.4	2.6	2.5						
32.0	1.7	1.9	2.1	2.0	2.4	2.4						
34.0	1.3	1.5	1.7	1.6	2.0	2.3						
36.0	1.0	1.2	1.3	1.3	1.6	2.0						
38.0	0.7	0.9	1.0	1.0	1.3	1.7						
40.0		0.6	0.7	0.8	1.0	1.3						
42.0				0.5	0.8	1.1						
44.0					0.6	0.8						
46.0						0.5						
θ(°)	51~82	50~82	52~82	55~82	56~82	56~82						
標準フック	5.6t			5.6t								
フック重量	150kg			150kg								
標準巻掛本数	1			1								

注) カウンタウエイト 15t、アウトリガ張出幅 6.0m

● 51.2m ブーム+油圧チルトジブ (単位:t)

ジブ長さ(m)	10.0						18.0					
	オフセット			オフセット			オフセット			オフセット		
	5°	20°	40°	5°	20°	40°	5°	20°	40°	5°	20°	40°
12.0	4.4											
14.0	4.4											
16.0	4.4	4.4				2.7						
18.0	4.4	4.4				2.7						
20.0	4.4	4.1	3.9	2.7								
22.0	4.2	4.0	3.7	2.7	2.7							
24.0	3.8	3.8	3.6	2.7	2.7							
26.0	3.1	3.4	3.5	2.7	2.7	2.6						
28.0	2.5	2.8	3.1	2.7	2.6	2.5						
30.0	2.0	2.3	2.6	2.4	2.5	2.4						
32.0	1.6	1.8	2.1	1.9	2.4	2.3						
34.0	1.3	1.5	1.7	1.6	2.0	2.2						
36.0	0.9	1.1	1.3	1.2	1.6	2.0						
38.0	0.7	0.8	1.0	0.9	1.3	1.6						
40.0		0.5	0.7	0.7	1.0	1.3						
42.0					0.7	1.0						
44.0						0.5						
46.0						0.5						
θ(°)	54~82	53~82	55~82	60~82	58~82	59~82						
標準フック	5.6t			5.6t								
フック重量	150kg			150kg								
標準巻掛本数	1			1								

注) カウンタウエイト 15t、アウトリガ張出幅 6.0m

## J 性能

● 33.2m ブーム+油圧チルトジブ (単位:t)

ジブ長さ(m)	10.0						18.0					
	オフセット			オフセット			オフセット			オフセット		
	5°	20°	40°	5°	20°	40°	5°	20°	40°	5°	20°	40°
8.0	10.1											
9.0	10.1											
10.0	10.1	8.9			4.2							
11.0	9.7	8.5			4.2							
12.0	9.3	8.1			4.2							
14.0	8.2	7.5	6.6	4.2	4.2							
16.0	6.3	6.9	6.2	4.2	4.2							
18.0	4.9	5.4	5.9	4.2	4.1							
20.0	3.8	4.3	4.7	4.2	3.9	3.2						
22.0	3.0	3.4	3.7	3.7	3.8	3.0						
24.0	2.3	2.6	3.0	3.0	3.6	2.9						
26.0	1.8	2.0	2.3	2.4	2.9	2.9						
28.0	1.3	1.5	1.8	1.9	2.4	2.8						
30.0	0.9	1.1	1.3	1.5	1.9	2.4						
32.0	0.6	0.7	0.9	1.2	1.5	1.9						
34.0				0.9	1.2	1.5						
36.0				0.6	0.9	1.1						
38.0					0.6	0.8						
40.0						0.5						
θ(°)	41~82	43~82	46~82	47~82	47~82	47~82						
標準フック	18t			5.6t								
フック重量	300kg			150kg								
標準巻掛本数	2			1								

注) カウンタウエイト 9t、アウトリガ張出幅 6.0m

● 47.9m ブーム+油圧チルトジブ (単位:t)

ジブ長さ(m)	10.0						18.0					
	オフセット			オフセット			オフセット			オフセット		
	5°	20°	40°	5°	20°	40°	5°	20°	40°	5°	20°	40°
11.0	4.9											
12.0	4.9											
14.0	4.9					2.9						
16.0	4.9	4.9				2.9						
18.0	4.9	4.7	4.4	2.9								
20.0	4.0	4.4	4.2	2.9	2.9							
22.0	3.2	3.6	4.0	2.9	2.9							
24.0	2.5	2.9	3.2	2.9	2.9							
26.0	1.9	2.3	2.6	2.3	2.9	2.7						
28.0	1.5	1.7	2.0	1.8	2.3	2.6						
30.0	1.1	1.3	1.6	1.4	1.9	2.4						
32.0	0.7	0.9	1.2	1.1	1.5	1.9						
34.0			0.8	0.8	1.1	1.5						
36.0				0.5	0.8	1.2						
38.0					0.5	0.9						
40.0						0.6						
θ(°)	59~82	61~82	60~82	61~82	63~82	64~82						
標準フック	5.6t			5.6t								
フック重量	150kg			150kg								
標準巻掛本数	1			1								

注) カウンタウエイト 9t、アウトリガ張出幅 6.0m

● 51.2m ブーム+油圧チルトジブ (単位:t)

ジブ長さ(m)	10.0						18.0					
	オフセット			オフセット			オフセット			オフセット		
	5°	20°	40°	5°	20°	40°	5°	20°	40°	5°	20°	40°
12.0	4.4											
14.0	4.4											
16.0	4.4	4.4				2.7						
18.0	4.4	4.4				2.7						
20.0	4.0	4.1	3.9	2.7								
22.0	3.1	3.5	3.7	2.7	2.7							
24.0	2.5	2.8	3.2	2.7	2.7							
26.0	1.9	2.2	2.6	2.2	2.7	2.6						
28.0	1.4	1.7	2.0	1.8	2.3	2.5						
30.0	1.0	1.3	1.5	1.3	1.8	2.3						
32.0	0.9	1.1	1.0	1.4	1.9							
34.0				0.7	1.1	1.5						
36.0					0.8	1.2						
38.0						0.8						
θ(°)	64~82	63~82	65~82	66~82	67~82	68~82						
標準フック	5.6t			5.6t								
フック重量	150kg			150kg								
標準巻掛本数	1											