

KATO KA-3000R

■寸法図

KA-3000R

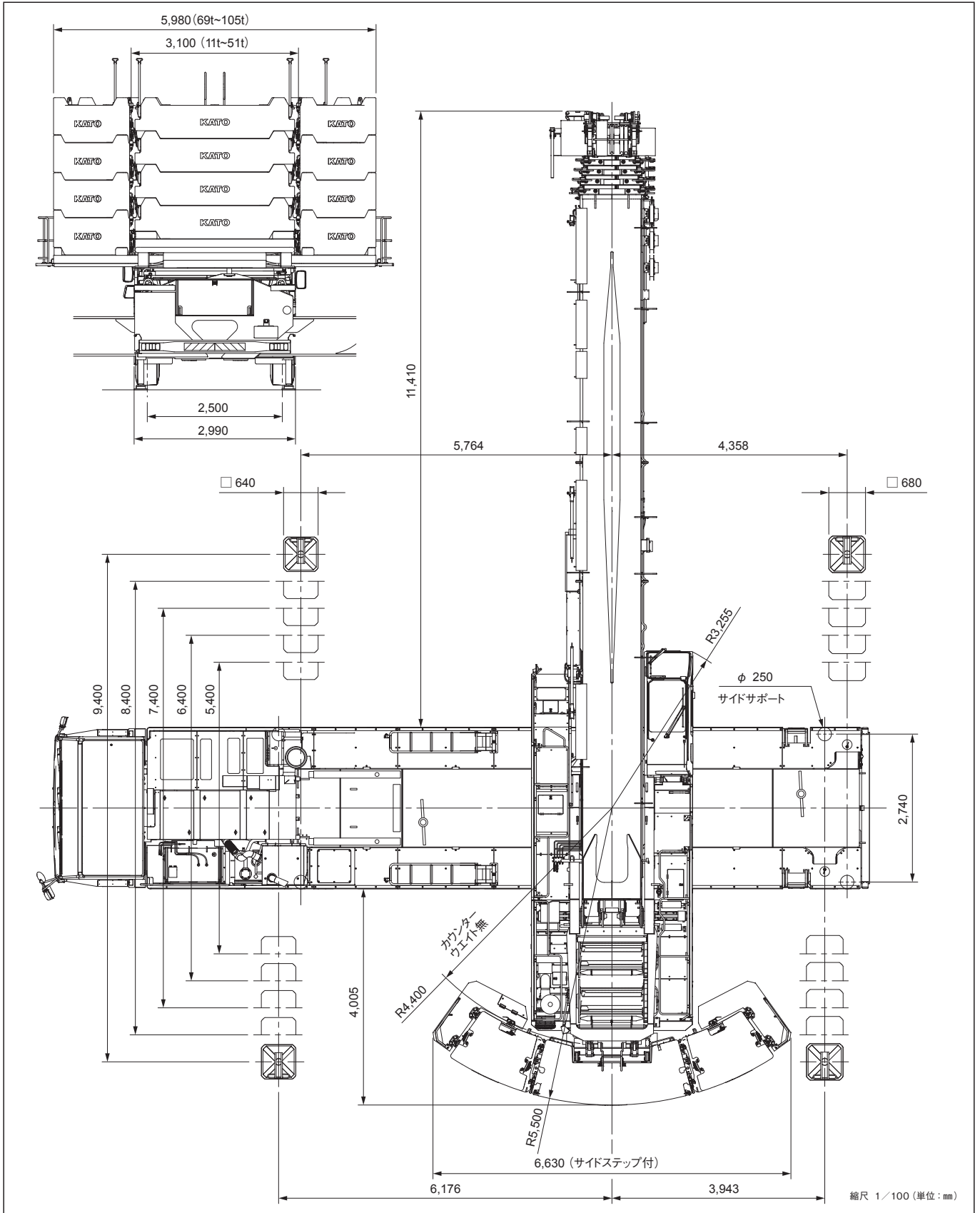

KATO KA-3000R

■ 寸法図

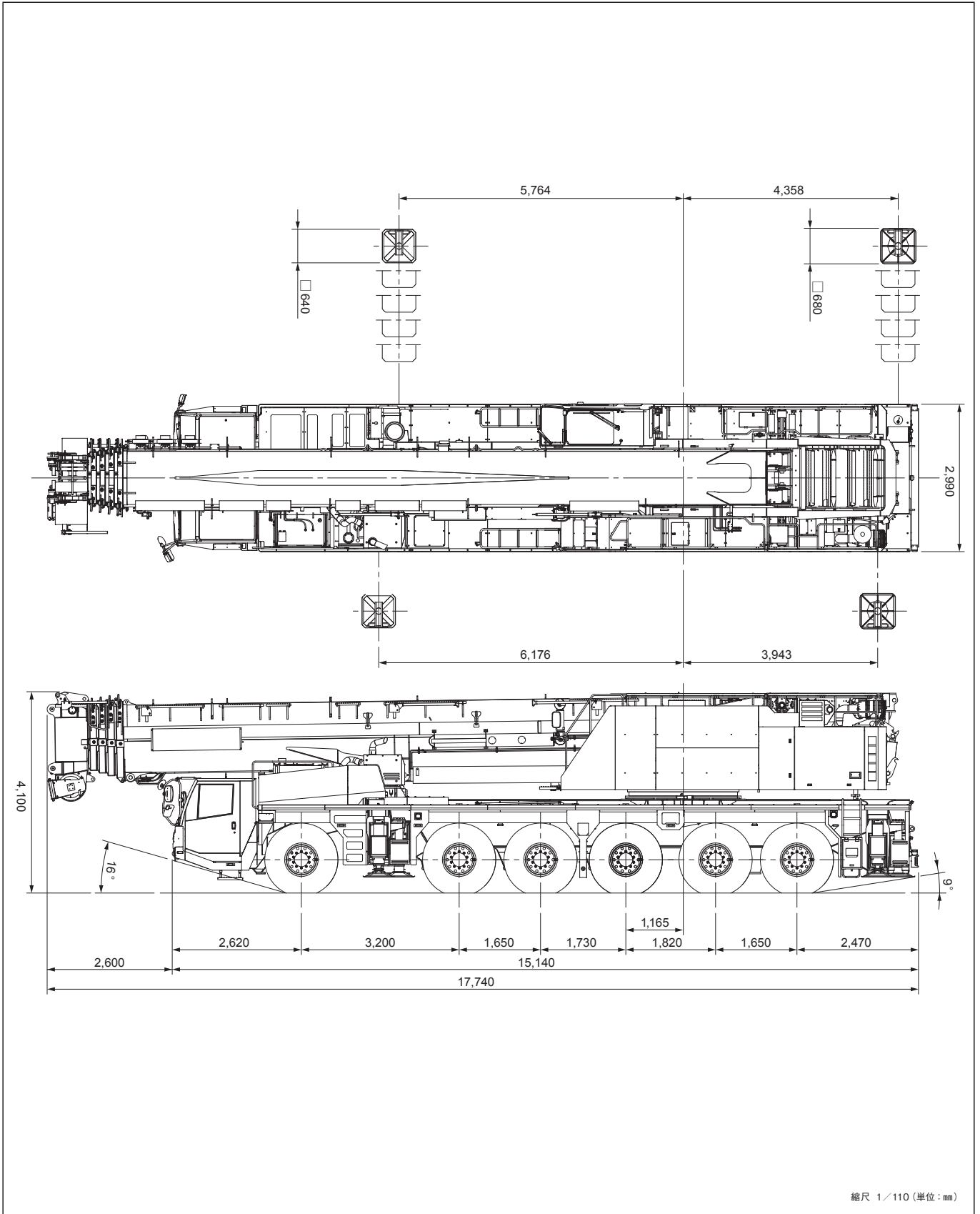

KA-3000R

KATO KA-3000R

■ 寸法図

KA-3000R

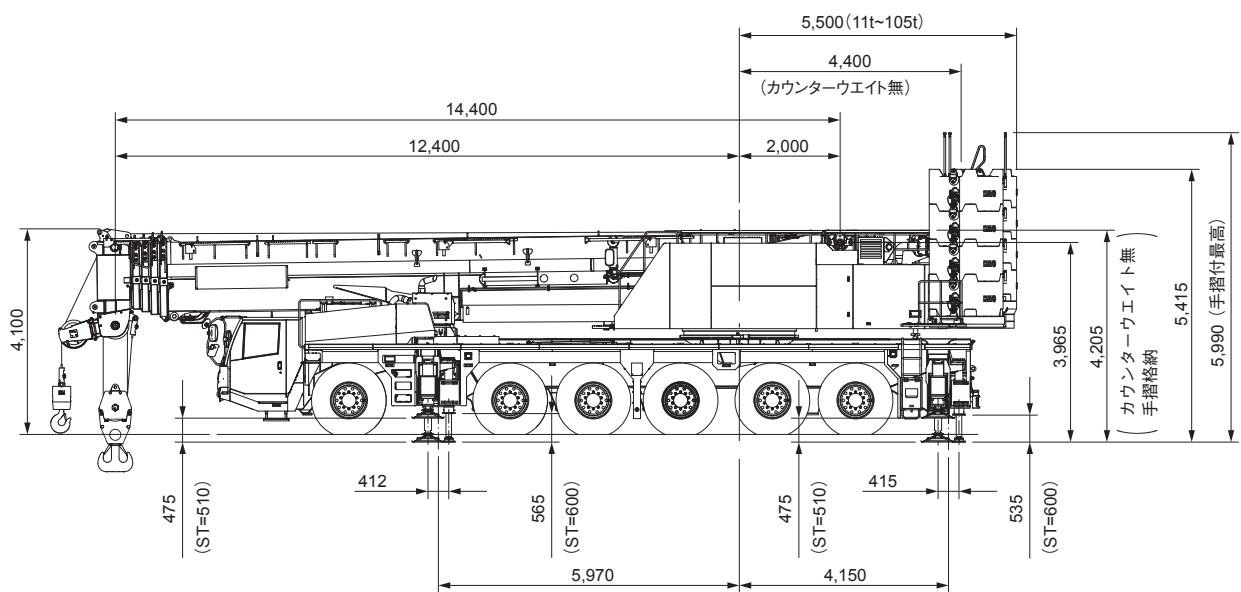
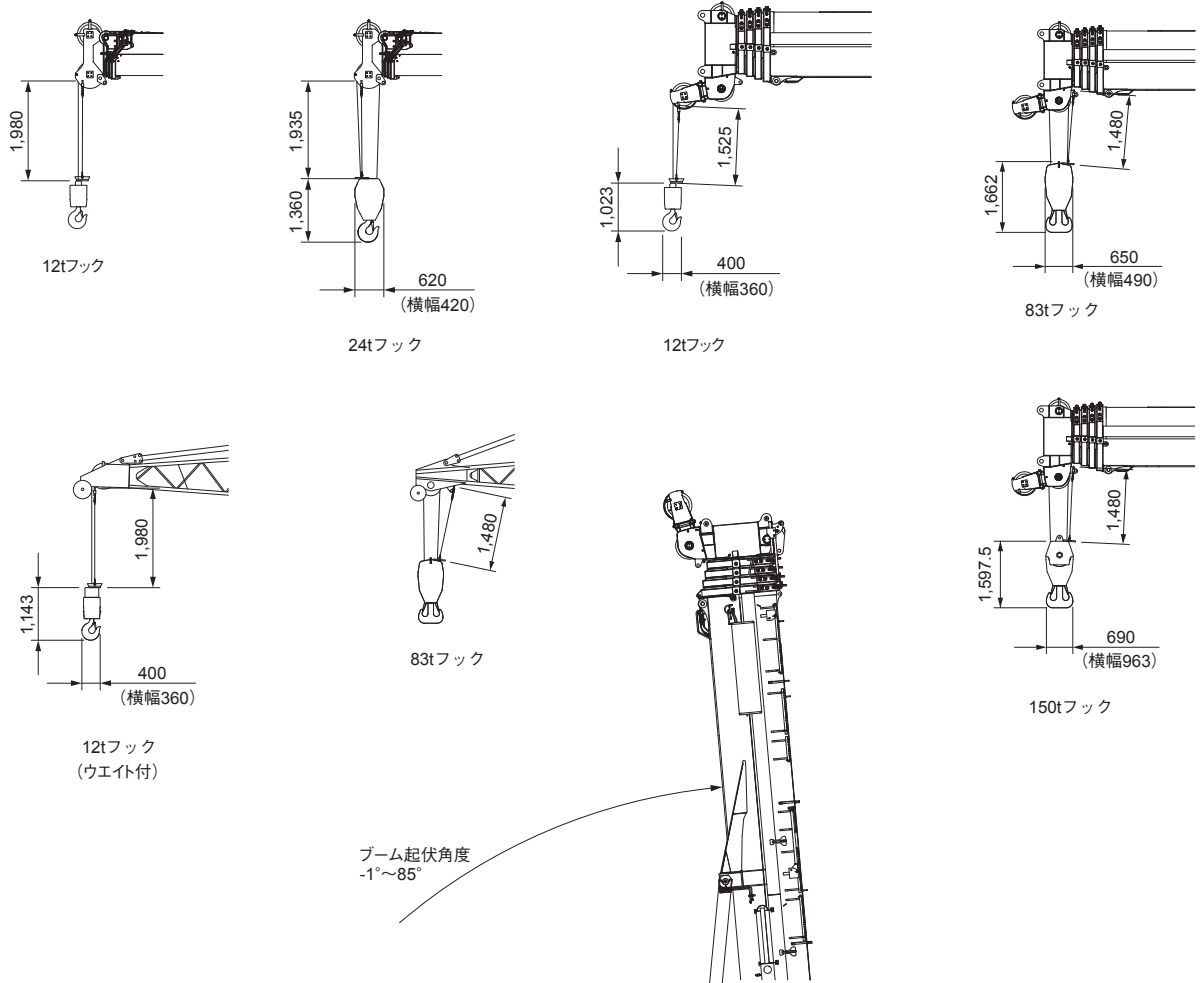

縮尺 1/150 (単位: mm)

KATO KA-3000R

KA-3000R

■公道走行状態

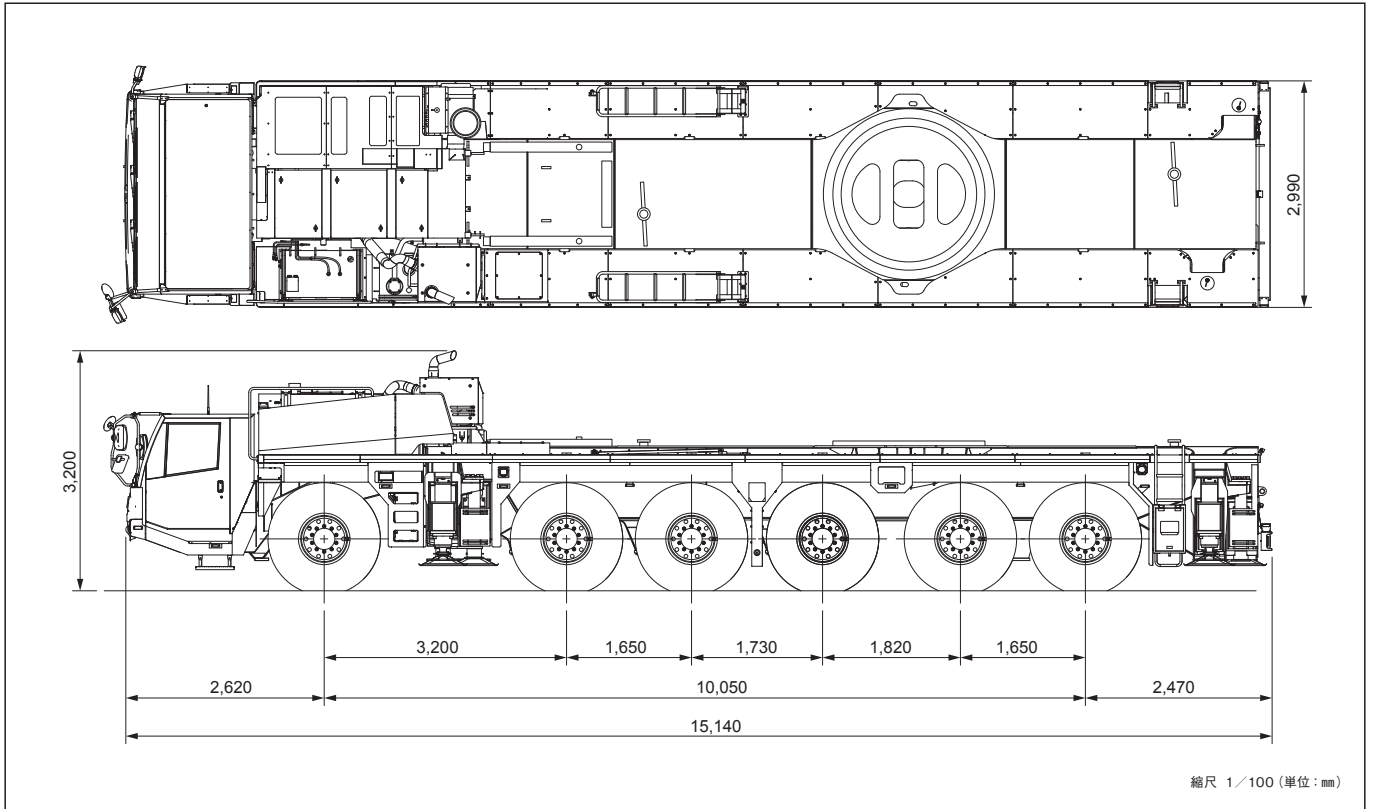

■最小直角通路幅

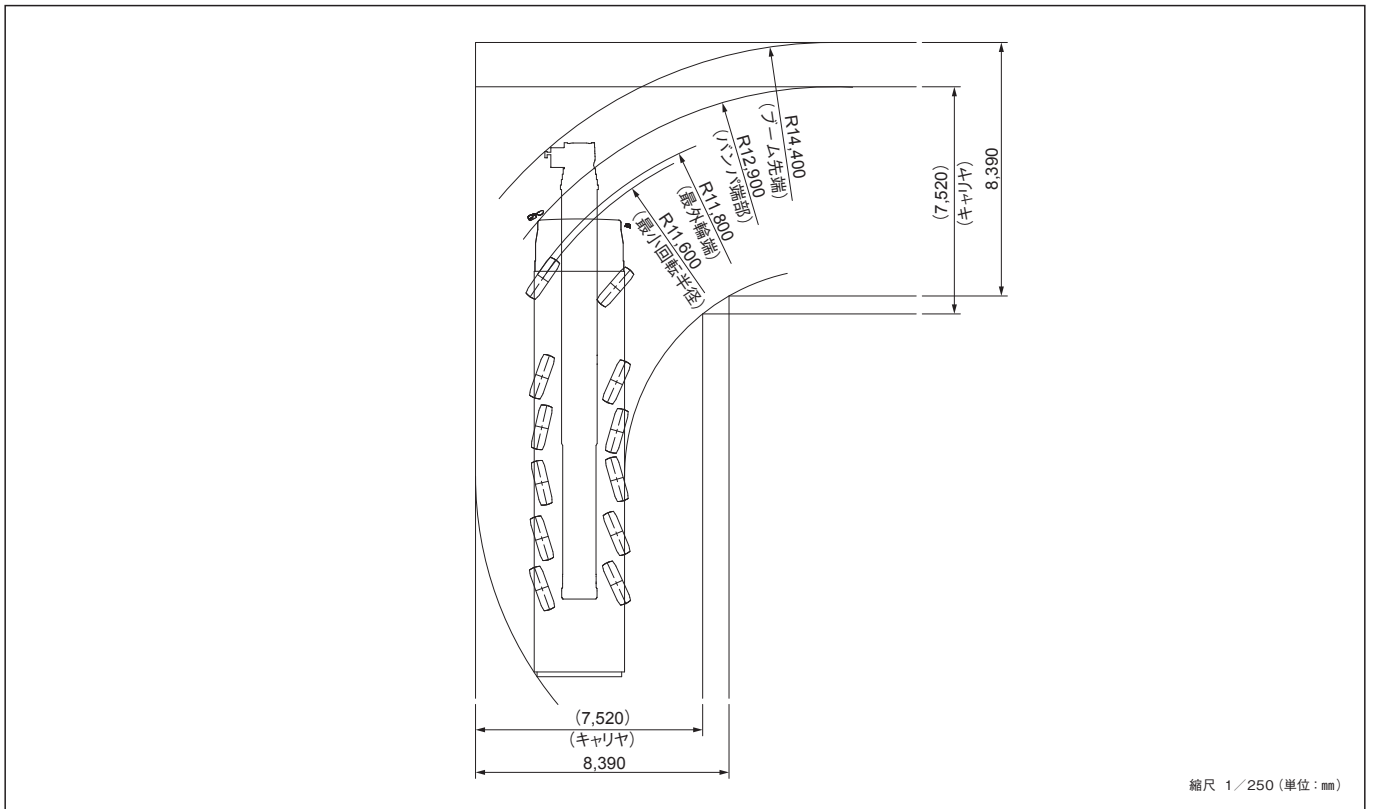

KATO KA-3000R

■作業範囲図

●メインブーム【通常伸縮】

- | | |
|--------------|-----------------------|
| Ⓐ 14.4m ブーム | Ⓧ 14.4m ブーム+ルースターシーブ |
| Ⓑ 19.55m ブーム | Ⓨ 19.55m ブーム+ルースターシーブ |
| Ⓒ 23.6m ブーム | Ⓩ 23.6m ブーム+ルースターシーブ |
| Ⓓ 24.7m ブーム | ⓓ 24.7m ブーム+ルースターシーブ |
| Ⓔ 32.0m ブーム | Ⓝ 32.0m ブーム+ルースターシーブ |
| Ⓕ 40.0m ブーム | Ⓟ 40.0m ブーム+ルースターシーブ |
| Ⓖ 45.0m ブーム | Ⓠ 45.0m ブーム+ルースターシーブ |
| Ⓗ 50.0m ブーム | Ⓡ 50.0m ブーム+ルースターシーブ |
| Ⓙ 55.0m ブーム | Ⓢ 55.0m ブーム+ルースターシーブ |

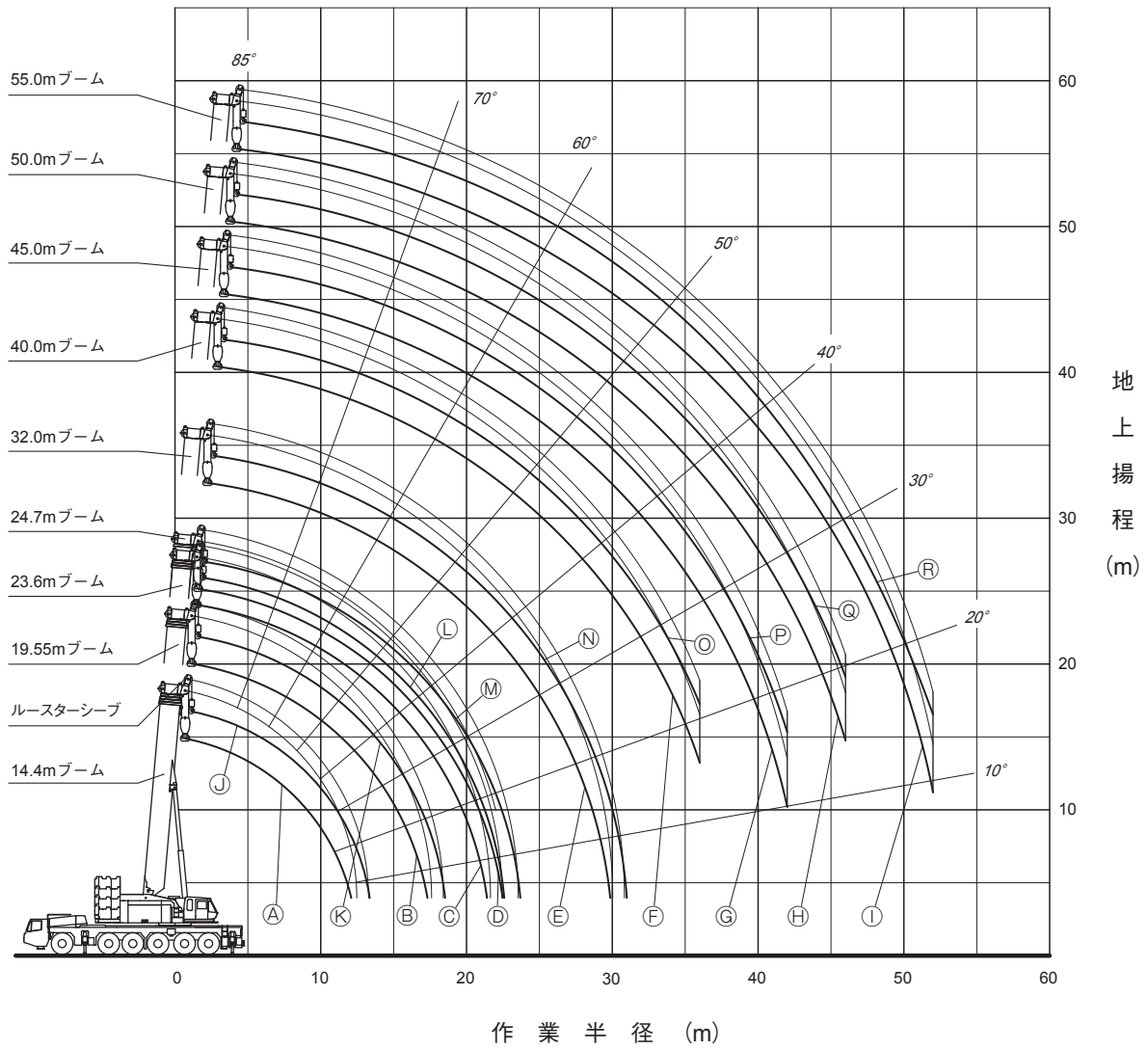

(注) 1. 本図は、ブームのたわみを含んでいません。
2. A1性能時のものを示しています。

縮尺 1/500

KA-3000R

KATO KA-3000R

■定格総荷重表

●メインブーム14.4m — 55.0m (単位: t)

A1性能 作業半径 (m)	アウトリガ (9.4m) 張出 (全周)					カウンタウエイト 105t				
	14.4m ブーム	19.55m ブーム	23.6m ブーム	24.7m ブーム	32.0m ブーム	40.0m ブーム	45.0m ブーム	50.0m ブーム	55.0m ブーム	
3.0	150.0									
3.5	150.0	120.0								
4.0	150.0	120.0	120.0	120.0						
4.5	150.0	120.0	120.0	120.0						
5.0	150.0	120.0	120.0	120.0	70.0					
6.0	144.9	120.0	120.0	120.0	70.0					
7.0	126.4	120.0	120.0	120.0	70.0	60.0				
8.0	111.8	110.1	109.2	109.0	70.0	60.0	47.0	38.0		
9.0	99.8	98.2	97.3	97.1	70.0	60.0	47.0	38.0	32.0	
10.0	89.9	88.2	87.3	87.1	70.0	60.0	47.0	38.0	32.0	
11.0	81.6	79.9	78.9	78.7	70.0	60.0	47.0	38.0	32.0	
12.0	72.4	72.7	71.8	71.6	70.0	60.0	47.0	38.0	32.0	
14.0		61.2	60.2	60.0	61.8	52.6	47.0	38.0	32.0	
16.0		52.3	51.3	51.1	53.0	46.5	42.4	38.0	31.0	
18.0			44.2	44.0	45.8	41.3	38.1	35.1	27.3	
20.0			38.4	38.2	40.0	37.0	34.5	31.1	24.3	
22.0				30.4	35.2	33.4	31.1	27.9	21.7	
24.0					30.8	30.3	28.2	25.1	19.6	
26.0					27.1	27.7	25.7	22.8	17.7	
28.0					23.9	25.0	23.5	20.8	16.1	
30.0						22.3	21.6	19.0	14.7	
32.0						19.9	20.0	17.5	13.4	
34.0						17.8	18.3	16.1	12.3	
36.0						15.9	16.4	14.9	11.3	
38.0							14.8	13.8	10.4	
40.0							13.3	12.8	9.6	
42.0							9.9	11.9	8.9	
44.0								11.0	8.2	
46.0								9.9	7.6	
48.0									7.1	
50.0									6.6	
52.0									5.2	
危険角度(°)	-	-	-	-	-	2	3	5	7	
フック種類	150t					83t				
フック質量(t)	1.90					1.0				
巻掛本数	14	12			7	6	4			

●メインブーム14.4m — 55.0m (単位: t)

A2性能 作業半径 (m)	アウトリガ (8.4m) 張出 (側方)					カウンタウエイト 105t				
	14.4m ブーム	19.55m ブーム	23.6m ブーム	24.7m ブーム	32.0m ブーム	40.0m ブーム	45.0m ブーム	50.0m ブーム	55.0m ブーム	
3.0	150.0									
3.5	150.0	120.0								
4.0	150.0	120.0	120.0	120.0						
4.5	150.0	120.0	120.0	120.0						
5.0	150.0	120.0	120.0	120.0	70.0					
6.0	144.9	120.0	120.0	120.0	70.0					
7.0	126.4	120.0	120.0	120.0	70.0	60.0				
8.0	111.8	110.1	109.2	109.0	70.0	60.0	47.0	38.0		
9.0	99.8	98.2	97.3	97.1	70.0	60.0	47.0	38.0	32.0	
10.0	89.9	88.2	87.3	87.1	70.0	60.0	47.0	38.0	32.0	
11.0	81.6	79.9	78.9	78.7	70.0	60.0	47.0	38.0	32.0	
12.0	72.4	72.7	71.8	71.6	70.0	60.0	47.0	38.0	32.0	
14.0		61.2	60.2	60.0	61.8	52.6	47.0	38.0	32.0	
16.0		52.3	51.3	51.1	53.0	46.5	42.4	38.0	31.0	
18.0			44.2	44.0	45.8	41.3	38.1	35.1	27.3	
20.0			38.4	38.2	40.0	37.0	34.5	31.1	24.3	
22.0				30.4	35.2	33.4	31.1	27.9	21.7	
24.0					30.8	30.3	28.2	25.1	19.6	
26.0					27.1	27.7	25.7	22.8	17.7	
28.0					23.9	25.0	23.5	20.8	16.1	
30.0						22.3	21.6	19.0	14.7	
32.0						19.9	20.0	17.5	13.4	
34.0						17.8	18.3	16.1	12.3	
36.0						15.9	16.4	14.9	11.3	
38.0							14.8	13.8	10.4	
40.0							13.3	12.8	9.6	
42.0							9.9	11.9	8.9	
44.0								11.0	8.2	
46.0								9.9	7.6	
48.0									7.1	
50.0									6.6	
52.0									5.2	
危険角度(°)	-	-	-	-	-	2	3	5	7	
フック種類	150t					83t				
フック質量(t)	1.90					1.0				
巻掛本数	14	12			7	6	4			

●メインブーム14.4m — 55.0m (単位: t)

B1性能 作業半径 (m)	アウトリガ (9.4m) 張出 (全周)					カウンタウエイト 93t				
	14.4m ブーム	19.55m ブーム	23.6m ブーム	24.7m ブーム	32.0m ブーム	40.0m ブーム	45.0m ブーム	50.0m ブーム	55.0m ブーム	
3.0	150.0									
3.5	150.0	120.0								
4.0	150.0	120.0	120.0	120.0						
4.5	150.0	120.0	120.0	120.0						
5.0	150.0	120.0	120.0	120.0	70.0					
6.0	140.6	120.0	120.0	120.0	70.0					
7.0	122.6	120.0	120.0	120.0	70.0	60.0				
8.0	108.3	106.7	105.8	105.6	70.0	60.0	47.0	38.0		
9.0	96.7	95.1	94.2	93.9	70.0	60.0	47.0	38.0	32.0	
10.0	87.1	85.4	84.5	84.3	70.0	60.0	47.0	38.0	32.0	
11.0	79.0	77.2	76.3	76.1	70.0	60.0	47.0	38.0	32.0	
12.0	72.1	70.3	69.4	69.2	70.0	60.0	47.0	38.0	32.0	
14.0		59.0	58.1	57.9	59.8	52.6	47.0	38.0	32.0	
16.0		50.4	49.4	49.2	51.1	46.5	42.4	38.0	31.0	
18.0			42.0	41.8	43.9	41.3	38.1	35.1	27.3	
20.0			35.8	35.6	37.6	37.0	34.5	31.1	24.3	
22.0				30.4	32.5	33.4	31.1	27.9	21.7	
24.0					28.3	29.4	28.2	25.1	19.6	
26.0					24.7	25.9	25.7	22.8	17.7	
28.0					21.7	22.8	23.5	20.8	16.1	
30.0						20.2	20.9	19.0	14.7	
32.0						17.9	18.5	17.5	13.4	
34.0						16.0	16.5	16.1	12.3	
36.0						14.2	14.7	14.9	11.3	
38.0							13.2	13.5	10.4	
40.0							11.7	12.1	9.6	
42.0							9.9	10.8	8.9	
44.0								9.6	8.2	
46.0								8.6	7.6	
48.0									7.1	
50.0									6.6	
52.0									5.2	
危険角度(°)	-	-	-	-	-	2	3	5	7	
フック種類	150t					83t				
フック質量(t)	1.90					1.0				
巻掛本数	14	12			7	6	4			

●メインブーム14.4m — 55.0m (単位: t)

B2性能 作業半径 (m)	アウトリガ (8.4m) 張出 (側方)					カウンタウエイト 93t				
	14.4m ブーム	19.55m ブーム	23.6m ブーム	24.7m ブーム	32.0m ブーム	40.0m ブーム	45.0m ブーム	50.0m ブーム	55.0m ブーム	
3.0	150.0									
3.5	150.0	120.0								
4.0	150.0	120.0	120.0	120.0						
4.5	150.0	120.0	120.0	120.0						
5.0	150.0	120.0	120.0	120.0	70.0					
6.0	140.6	120.0	120.0	120.0	70.0					
7.0	122.6	120.0	120.0	120.0	70.0	60.0				
8.0	108.3	106.7	105.8	105.6	70.0	60.0	47.0	38.0		
9.0	96.7	95.1	94.2	93.9	70.0	60.0	47.0	38.0	32.0	
10.0	87.1	85.4	84.5	84.3	70.0	60.0	47.0	38.0	32.0	
11.0	79.0	77.2	76.3	76.1	70.0	60.0	47.0	38.0	32.0	
12.0	72.1	70.3	69.4	69.2	70.0	60.0	47.0	38.0	32.0	
14.0		59.0	58.1	57.9	59.8	52.6	47.0	38.0	32.0	
16.0		50.4	49.4	49.2	51.1	46.5	42.4	38.0	31.0	
18.0			42.0	41.8	43.9	41.3	38.1	35.1	27.3	
20.0			35.8	35.6	37.6	37.0	34.5	31.1	24.3	
22.0				30.4	32.5	33.4	31.1	27.9	21.7	
24.0					28.3	29.4	28.2	25.1	19.6	
26.0					24.7	25.9	25.7	22.8	17.7	
28.0					21.7	22.8	23.5	20.8	16.1	
30.0						20.2	20.9	19.0	14.7	
32.0						17.9	18.5	17.5	13.4	
34.0						16.0	16.5	16.1	12.3	
36.0						14.2	14.7	14.9	11.3	
38.0							13.2	13.5	10.4	
40.0							11.7	12.1	9.6	
42.0							9.9	10.8	8.9	
44.0								9.6	8.2	
46.0								8.6	7.6	
48.0									7.1	
50.0									6.6	
52.0									5.2	
危険角度(°)	-	-	-	-	-	2	3	5	7	
フック種類	150t					83t				
フック質量(t)	1.90					1.0				
巻掛本数	14	12			7	6	4			

KATO KA-3000R

■定格総荷重表

●メインブーム14.4m — 55.0m

(単位:t)

C1性能 作業半径 (m)	アウトリガ (9.4m) 張出(全周)					カウンタウエイト 81t				
	14.4m ブーム	19.55m ブーム	23.6m ブーム	24.7m ブーム	32.0m ブーム	40.0m ブーム	45.0m ブーム	50.0m ブーム	55.0m ブーム	
3.0	150.0									
3.5	150.0	120.0								
4.0	150.0	120.0	120.0	120.0						
4.5	150.0	120.0	120.0	120.0						
5.0	150.0	120.0	120.0	120.0	70.0					
6.0	136.3	120.0	120.0	120.0	70.0					
7.0	118.8	117.2	116.4	116.2	70.0	60.0				
8.0	104.9	103.3	102.4	102.2	70.0	60.0	47.0	38.0		
9.0	93.6	92.0	91.1	90.9	70.0	60.0	47.0	38.0	32.0	
10.0	84.2	82.6	81.7	81.4	70.0	60.0	47.0	38.0	32.0	
11.0	76.4	74.6	73.7	73.5	70.0	60.0	47.0	38.0	32.0	
12.0	69.6	67.9	66.9	66.7	68.6	60.0	47.0	38.0	32.0	
14.0		56.7	55.6	55.4	57.7	52.6	47.0	38.0	32.0	
16.0		47.1	46.0	45.7	47.9	46.5	42.4	38.0	31.0	
18.0			38.6	38.3	40.4	41.3	38.1	35.1	27.3	
20.0			32.7	32.5	34.5	35.7	34.5	31.1	24.3	
22.0				27.8	29.7	30.9	31.1	27.9	21.7	
24.0					25.7	26.9	27.6	25.1	19.6	
26.0					22.4	23.5	24.2	22.8	17.7	
28.0					19.5	20.6	21.3	20.8	16.1	
30.0						18.2	18.8	19.0	14.7	
32.0						16.0	16.6	17.0	13.4	
34.0						14.2	14.7	15.1	12.3	
36.0						12.5	13.0	13.4	11.3	
38.0							11.6	11.9	10.4	
40.0							10.2	10.5	9.6	
42.0							9.1	9.3	8.9	
44.0								8.2	8.2	
46.0								7.3	7.5	
48.0									6.6	
50.0									5.8	
52.0									5.0	
危険角度(°)	-	-	-	-	-	2	3	5	7	
フック種類	150t					83t				
フック質量(t)	1.90					1.0				
巻掛本数	14	12			7	6	4			

●メインブーム14.4m — 55.0m

(単位:t)

C2性能 作業半径 (m)	アウトリガ (8.4m) 張出(側方)					カウンタウエイト 81t				
	14.4m ブーム	19.55m ブーム	23.6m ブーム	24.7m ブーム	32.0m ブーム	40.0m ブーム	45.0m ブーム	50.0m ブーム	55.0m ブーム	
3.0	150.0									
3.5	150.0	120.0								
4.0	150.0	120.0	120.0	120.0						
4.5	150.0	120.0	120.0	120.0						
5.0	150.0	120.0	120.0	120.0	70.0					
6.0	136.3	120.0	120.0	120.0	70.0					
7.0	118.8	117.2	116.4	116.2	70.0	60.0				
8.0	104.9	103.3	102.4	102.2	70.0	60.0	47.0	38.0		
9.0	93.6	92.0	91.1	90.9	70.0	60.0	47.0	38.0	32.0	
10.0	84.2	82.6	81.7	81.4	70.0	60.0	47.0	38.0	32.0	
11.0	76.4	74.6	73.7	73.5	70.0	60.0	47.0	38.0	32.0	
12.0	69.6	67.9	66.9	66.7	68.6	60.0	47.0	38.0	32.0	
14.0		56.7	55.6	55.4	57.7	52.6	47.0	38.0	32.0	
16.0		47.1	46.0	45.7	47.9	46.5	42.4	38.0	31.0	
18.0			38.6	38.3	40.4	41.3	38.1	35.1	27.3	
20.0			32.7	32.5	34.5	35.7	34.5	31.1	24.3	
22.0				27.8	29.7	30.9	31.1	27.9	21.7	
24.0					25.7	26.9	27.6	25.1	19.6	
26.0					22.4	23.5	24.2	22.8	17.7	
28.0					19.5	20.6	21.3	20.8	16.1	
30.0						18.2	18.8	19.0	14.7	
32.0						16.0	16.6	17.0	13.4	
34.0						14.2	14.7	15.1	12.3	
36.0						12.5	13.0	13.4	11.3	
38.0							11.6	11.9	10.4	
40.0							10.2	10.5	9.6	
42.0							9.1	9.3	8.9	
44.0								8.2	8.2	
46.0								7.3	7.5	
48.0									6.6	
50.0									5.8	
52.0									5.0	
危険角度(°)	-	-	-	-	-	2	3	5	7	
フック種類	150t					83t				
フック質量(t)	1.90					1.0				
巻掛本数	14	12			7	6	4			

KA-3000R

KATO KA-3000R

■定格総荷重表

●メインブーム14.4m — 55.0m (単位：t)

K1性能 作業半径 (m)	アウトリガ (9.4m) 張出 (全周) カウンタウエイト Ot								
	14.4m ブーム	19.55m ブーム	23.6m ブーム	24.7m ブーム	32.0m ブーム	40.0m ブーム	45.0m ブーム	50.0m ブーム	55.0m ブーム
3.0	150.0								
3.5	150.0	120.0							
4.0	146.8	120.0	120.0	120.0					
4.5	130.4	120.0	120.0	120.0					
5.0	114.1	111.9	110.8	110.5	70.0				
6.0	90.2	88.2	87.1	86.8	70.0				
7.0	73.8	71.7	70.6	70.4	70.0	60.0			
8.0	61.7	59.7	58.6	58.4	60.8	60.0	47.0	38.0	
9.0	52.5	50.5	49.4	49.2	51.6	52.9	47.0	38.0	32.0
10.0	45.2	43.2	42.2	41.9	44.3	45.6	45.3	38.0	32.0
11.0	39.3	37.3	36.0	35.7	38.4	38.9	38.2	37.1	32.0
12.0	32.7	30.4	29.2	28.9	31.5	33.0	32.7	31.8	31.0
14.0		21.0	19.9	19.7	22.0	23.3	24.1	23.9	23.4
16.0		15.1	14.0	13.8	15.9	17.1	17.9	18.2	18.0
18.0			9.7	9.4	11.6	12.8	13.5	13.8	13.9
20.0			6.0	5.7	8.2	9.6	10.2	10.6	10.8
22.0					5.3	6.7	7.5	8.0	8.2
24.0						4.3	5.1	5.6	5.9
26.0							3.2	3.6	3.9
危険角度(°)	-	-	-	28	42	50	52	57	62
フック種類	150t				83t				
フック質量(t)	1.90				1.0				
巻掛本数	14	12			7	6		4	

●メインブーム14.4m — 55.0m (単位：t)

K2性能 作業半径 (m)	アウトリガ (8.4m) 張出 (側方) カウンタウエイト Ot								
	14.4m ブーム	19.55m ブーム	23.6m ブーム	24.7m ブーム	32.0m ブーム	40.0m ブーム	45.0m ブーム	50.0m ブーム	55.0m ブーム
3.0	150.0								
3.5	150.0	120.0							
4.0	146.8	120.0	120.0	120.0					
4.5	130.4	120.0	120.0	120.0					
5.0	114.1	111.9	110.8	110.5	70.0				
6.0	90.2	88.2	87.1	86.8	70.0				
7.0	73.8	71.7	70.6	70.4	70.0	60.0			
8.0	61.7	59.7	58.6	58.4	58.6	55.1	47.0	38.0	
9.0	49.6	47.1	45.7	45.4	46.8	44.7	43.6	38.0	32.0
10.0	39.0	36.7	35.4	35.1	37.9	37.0	36.3	35.2	32.0
11.0	31.6	29.3	28.2	27.9	30.5	31.0	30.6	29.8	28.9
12.0	26.1	23.9	22.8	22.5	24.9	26.2	26.1	25.5	24.8
14.0		16.4	15.3	15.1	17.3	18.5	19.2	18.9	18.5
16.0		11.4	10.4	10.1	12.2	13.4	14.1	14.2	14.0
18.0			6.1	5.8	8.4	9.8	10.4	10.6	10.5
20.0					5.1	6.6	7.4	7.8	7.8
22.0						4.0	4.8	5.3	5.6
危険角度(°)	-	-	34	38	48	54	59	62	66
フック種類	150t				83t				
フック質量(t)	1.90				1.0				
巻掛本数	14	12			7	6		4	

●メインブーム14.4m — 55.0m (単位：t)

K3性能 作業半径 (m)	アウトリガ (7.4m) 張出 (側方) カウンタウエイト Ot								
	14.4m ブーム	19.55m ブーム	23.6m ブーム	24.7m ブーム	32.0m ブーム	40.0m ブーム	45.0m ブーム	50.0m ブーム	55.0m ブーム
3.0	150.0								
3.5	150.0	120.0							
4.0	146.8	120.0	120.0	120.0					
4.5	130.4	120.0	120.0	120.0					
5.0	114.1	111.9	110.8	110.5	70.0				
6.0	90.2	88.2	85.1	82.8	70.0				
7.0	64.1	61.4	59.9	59.6	57.8	53.8			
8.0	46.6	44.2	43.0	42.7	45.2	42.8	41.6	38.0	
9.0	35.7	33.6	32.4	32.1	34.7	34.8	34.1	33.0	31.8
10.0	28.3	26.3	25.2	24.9	27.3	28.6	28.4	27.6	26.7
11.0	22.9	21.0	20.0	19.7	21.9	23.2	23.8	23.2	22.6
12.0	18.9	17.0	16.0	15.8	17.9	19.1	19.8	19.7	19.2
14.0		11.3	10.4	10.2	12.1	13.2	13.9	14.2	14.0
16.0		7.5	6.3	6.1	8.2	9.3	9.9	10.2	10.2
18.0					5.0	6.5	7.1	7.3	7.3
20.0							4.5		
危険角度(°)	-	-	43	46	53	60	63	67	70
フック種類	150t				83t				
フック質量(t)	1.90				1.0				
巻掛本数	14	12			7	6		4	

●メインブーム14.4m — 55.0m (単位：t)

K4性能 作業半径 (m)	アウトリガ (6.4m) 張出 (側方) カウンタウエイト Ot								
	14.4m ブーム	19.55m ブーム	23.6m ブーム	24.7m ブーム	32.0m ブーム	40.0m ブーム	45.0m ブーム	50.0m ブーム	55.0m ブーム
3.0	150.0								
3.5	150.0	120.0							
4.0	146.8	120.0	120.0	120.0					
4.5	130.4	120.0	110.0	106.5					
5.0	111.7	99.7	88.6	86.0	70.0				
6.0	67.8	65.0	61.8	60.1	56.9				
7.0	47.0	44.6	43.3	43.1	43.3	40.7			
8.0	34.9	32.7	31.6	31.3	33.9	32.4	31.7	30.5	
9.0	26.9	25.0	23.9	23.7	26.0	26.2	25.9	25.0	24.2
10.0	21.3	19.5	18.5	18.2	20.4	21.5	21.3	20.8	20.1
11.0	17.2	15.4	14.4	14.2	16.3	17.5	17.7	17.3	16.8
12.0	14.0	12.3	11.3	11.1	13.1	14.2	14.7	14.4	14.1
14.0		7.7	6.6	6.4	8.5	9.6	10.1	10.0	9.8
16.0					4.9	6.3	6.7	6.7	
危険角度(°)	-	35	50	52	57	65	68	71	74
フック種類	150t				83t				
フック質量(t)	1.90				1.0				
巻掛本数	14	12			7	6		4	

●メインブーム14.4m — 55.0m (単位：t)

K5性能 作業半径 (m)	アウトリガ (5.4m) 張出 (側方) カウンタウエイト Ot								
	14.4m ブーム	19.55m ブーム	23.6m ブーム	24.7m ブーム	32.0m ブーム	40.0m ブーム	45.0m ブーム	50.0m ブーム	55.0m ブーム
3.0	150.0								
3.5	150.0	120.0							
4.0	129.2	107.0	93.6	90.5					
4.5	90.4	84.7	74.9	72.6					
5.0	68.4	65.8	61.6	59.8	55.7				
6.0	44.5	42.3	41.1	40.8	41.0				
7.0	31.7	29.8	28.7	28.5	30.8	29.7			
8.0	23.7	21.9	21.0	20.7	22.9	23.4	23.1	22.2	
9.0	18.3	16.6	15.7	15.5	17.5	18.6	18.6	18.0	17.4
10.0	14.4	12.8	11.9	11.7	13.6	14.7	15.0	14.7	14.2
11.0	11.4	9.8	9.0	8.8	10.6	11.7	12.2	11.9	11.6
12.0	9.1	7.5	6.7	6.5	8.3	9.3	9.8	9.6	9.4
危険角度(°)	-	47	56	58	64	70	73	76	77
フック種類	150t				83t				
フック質量(t)	1.90				1.0				
巻掛本数	14	12			7	6		4	

KATO KA-3000R

■作業範囲図

●スーパーラフィングジブ【55mブーム時】

- | | |
|---|--|
| Ⓐ 55m ブーム + 2m + 10.85m SLジブ (オフセット 5°) | ⓐ 55m ブーム + 2m + 10.85m SLジブ (オフセット 60°) |
| Ⓑ 55m ブーム + 2m + 15m SLジブ (オフセット 0°) | ⓑ 55m ブーム + 2m + 15m SLジブ (オフセット 60°) |
| Ⓒ 55m ブーム + 2m + 20m SLジブ (オフセット 0°) | ⓒ 55m ブーム + 2m + 20m SLジブ (オフセット 60°) |
| Ⓓ 55m ブーム + 2m + 25m SLジブ (オフセット 0°) | ⓓ 55m ブーム + 2m + 25m SLジブ (オフセット 60°) |
| Ⓔ 55m ブーム + 2m + 30m SLジブ (オフセット 0°) | ⓔ 55m ブーム + 2m + 30m SLジブ (オフセット 60°) |
| Ⓕ 55m ブーム + 2m + 35m SLジブ (オフセット 0°) | ⓕ 55m ブーム + 2m + 35m SLジブ (オフセット 60°) |

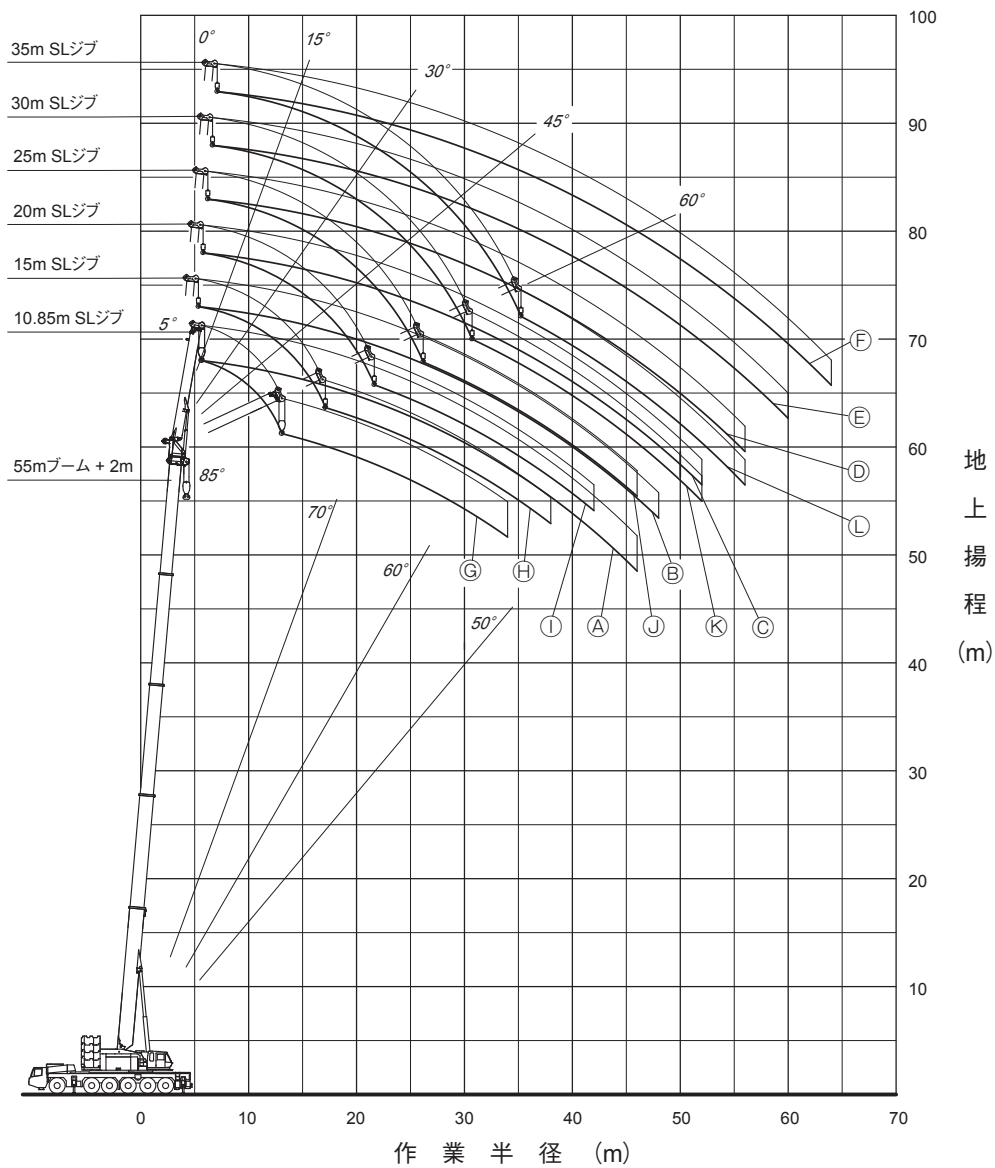

(注) 1. 本図は、ブームおよびSLジブのたわみを含んでいません。
 2. SA性能時のものを示しています。

縮尺 1/700

KA-3000R

KATO KA-3000R

■定格総荷重表

●55mブーム+2m+10.85mスーパーラフィングジブ

SA性能										
オフセット	5°		15°		30°		45°		60°	
作業半径 (m)	ブーム角度 (°)	荷重 (t)	ブーム角度 (°)	荷重 (t)	ブーム角度 (°)	荷重 (t)	ブーム角度 (°)	荷重 (t)	ブーム角度 (°)	荷重 (t)
8.0	84.7	18.0								
9.0	84.0	18.0								
10.0	83.4	18.0								
11.0	82.7	18.0	84.3	18.0						
12.0	82.0	18.0	83.7	18.0						
14.0	80.7	18.0	82.3	18.0	84.3	18.0				
16.0	79.3	18.0	80.9	18.0	82.7	17.5	84.1	15.8	84.8	13.8
18.0	77.9	18.0	79.5	18.0	81.0	15.9	82.3	14.5	83.2	13.8
20.0	76.5	18.0	77.8	16.3	79.3	14.5	80.6	13.3	81.3	12.7
22.0	74.8	16.2	76.1	14.8	77.6	13.2	78.8	12.3	79.4	11.8
24.0	73.0	14.6	74.3	13.4	75.8	12.1	77.0	11.3	77.5	11.0
26.0	71.2	13.0	72.5	12.2	74.1	11.1	75.2	10.5	75.6	10.2
28.0	69.3	11.5	70.7	11.2	72.3	10.2	73.3	9.7	73.5	9.5
30.0	67.5	10.1	68.9	10.2	70.4	9.4	71.3	9.0	71.5	8.9
32.0	65.6	8.9	66.9	9.0	68.5	8.7	69.2	8.3	69.3	8.3
34.0	63.7	7.9	64.8	7.9	66.5	8.0	67.2	7.7	67.1	7.7
36.0	61.8	6.9	62.8	7.0	64.5	7.1	65.0	7.1		
38.0	59.8	6.0	60.7	6.1	62.4	6.2	62.9	6.2		
40.0	57.6	5.2	58.5	5.3	60.5	5.4	60.5	5.5		
42.0	55.5	4.5	56.3	4.6	58.6	4.7	58.2	4.7		
44.0	53.2	3.9	54.0	3.9	56.6	4.0	55.7	4.1		
46.0	50.8	3.3	51.6	3.3	54.4	3.4	53.1	3.4		
48.0			49.2	2.8	52.2	2.8				
危険角度(°)	49		49		49		51		66	
標準フック	24t									
フック質量(t)	0.88									
巻掛本数	2									

●55mブーム+2m+15mスーパーラフィングジブ

SA性能										
オフセット	0°		15°		30°		45°		60°	
作業半径 (m)	ブーム角度 (°)	荷重 (t)	ブーム角度 (°)	荷重 (t)	ブーム角度 (°)	荷重 (t)	ブーム角度 (°)	荷重 (t)	ブーム角度 (°)	荷重 (t)
7.0	84.5	12.0								
8.0	83.8	12.0								
9.0	83.2	12.0								
10.0	82.6	12.0								
11.0	81.9	12.0								
12.0	81.3	12.0	84.4	12.0						
14.0	80.0	12.0	83.1	12.0						
16.0	78.7	12.0	81.8	12.0	84.4	12.0				
18.0	77.4	12.0	80.5	12.0	83.0	12.0				
20.0	76.0	12.0	79.1	12.0	81.6	12.0	83.5	11.6	84.7	10.2
22.0	74.7	12.0	77.8	12.0	80.0	11.8	81.8	10.8	83.0	10.2
24.0	73.3	12.0	76.4	12.0	78.4	10.9	80.1	10.0	81.2	9.5
26.0	71.9	12.0	74.8	11.2	76.7	10.0	78.4	9.3	79.4	8.9
28.0	70.2	11.8	73.1	10.3	75.1	9.2	76.6	8.6	77.5	8.3
30.0	68.5	10.6	71.4	9.4	73.4	8.5	74.8	8.0	75.6	7.8
32.0	66.8	9.4	69.7	8.6	71.6	7.9	73.0	7.4	73.7	7.3
34.0	65.1	8.3	68.0	8.0	69.9	7.3	71.1	6.9	71.7	6.8
36.0	63.3	7.4	66.3	7.3	68.0	6.8	69.2	6.5	69.7	6.4
38.0	61.5	6.5	64.5	6.7	66.2	6.3	67.2	6.0	67.6	6.0
40.0	59.6	5.7	62.5	5.9	64.2	5.8	65.1	5.6		
42.0	57.7	5.0	60.6	5.2	62.1	5.3	63.0	5.2		
44.0	55.7	4.4	58.6	4.5	60.0	4.7	60.8	4.7		
46.0	53.7	3.8	56.5	3.9	57.8	4.1	58.5	4.1		
48.0	51.6	3.2	54.3	3.4	55.6	3.5	56.1	3.5		
50.0			52.1	2.9	53.2	3.0	53.6	3.0		
52.0					50.7	2.5				
危険角度(°)	49.5		50		50		51		66	
標準フック	12t									
フック質量(t)	0.42									
巻掛本数	1									

●55mブーム+2m+20mスーパーラフィングジブ

SA性能										
オフセット	0°		15°		30°		45°		60°	
作業半径 (m)	ブーム角度 (°)	荷重 (t)	ブーム角度 (°)	荷重 (t)	ブーム角度 (°)	荷重 (t)	ブーム角度 (°)	荷重 (t)	ブーム角度 (°)	荷重 (t)
8.0	84.5	11.0								
9.0	84.0	11.0								
10.0	83.4	11.0								
11.0	82.8	11.0								
12.0	82.2	11.0								
14.0	81.1	11.0	84.7	11.0						
16.0	79.9	11.0	83.5	11.0						
18.0	78.6	11.0	82.3	11.0						
20.0	77.4	11.0	81.0	11.0	84.5	11.0				
22.0	76.1	11.0	79.7	11.0	83.0	10.3				
24.0	74.8	11.0	78.5	11.0	81.5	9.5	83.9	8.6		
26.0	73.5	11.0	76.9	10.0	79.9	8.8	82.3	8.0	83.9	7.5
28.0	72.0	10.8	75.4	9.2	78.4	8.1	80.6	7.4	82.2	7.1
30.0	70.5	9.8	73.9	8.4	76.8	7.5	78.9	6.9	80.4	6.6
32.0	69.0	8.9	72.3	7.8	75.2	7.0	77.2	6.5	78.6	6.2
34.0	67.5	8.1	70.7	7.1	73.6	6.5	75.4	6.0	76.7	5.8
36.0	65.9	7.4	69.1	6.6	71.9	6.0	73.7	5.6	74.8	5.5
38.0	64.3	6.8	67.5	6.1	70.1	5.6	71.8	5.2	72.9	5.1
40.0	62.6	6.0	65.8	5.6	68.3	5.1	70.0	4.9	70.8	4.8
42.0	60.8	5.3	64.0	5.1	66.5	4.8	68.1	4.6	68.7	4.5
44.0	59.0	4.7	62.2	4.7	64.7	4.4	66.1	4.2		
46.0	57.2	4.1	60.4	4.3	62.8	4.1	64.1	4.0		
48.0	55.2	3.5	58.5	3.8	60.8	3.8	62.0	3.7		
50.0	53.3	3.0	56.5	3.3	58.7	3.5	59.8	3.4		
52.0	51.2	2.6	54.4	2.8	56.5	3.0	57.4	3.0		
54.0			52.3	2.4	54.3	2.5	55.0	2.6		
56.0					52.0	2.1	52.5	2.1		
危険角度(°)	49.5		51		51		51		67	
標準フック	12t									
フック質量(t)	0.42									
巻掛本数	1									

●55mブーム+2m+25mスーパーラフィングジブ

SA性能										
オフセット	0°		15°		30°		45°		60°	
作業半径 (m)	ブーム角度 (°)	荷重 (t)	ブーム角度 (°)	荷重 (t)	ブーム角度 (°)	荷重 (t)	ブーム角度 (°)	荷重 (t)	ブーム角度 (°)	荷重 (t)
9.0	84.4	9.0								
10.0	83.9	9.0								
11.0	83.3	9.0								
12.0	82.7	9.0								
14.0	81.6	9.0								
16.0	80.5	9.0	84.9	9.0						
18.0	79.3	9.0	83.8	9.0						
20.0	78.2	9.0	82.6	9.0						
22.0	77.0	9.0	81.4	9.0						
24.0	75.8	9.0	80.2	9.0	84.1	8.5				
26.0	74.6	9.0	79.0	9.0	82.6	7.9				
28.0	73.4	9.0	77.6	8.4	81.2	7.3	84.1	6.6		
30.0	72.2	9.0	76.2	7.7	79.7	6.8	82.5	6.2	84.3	5.8
32.0	70.8	8.3	74.8	7.1	78.1	6.3	81.0	5.8	82.6	5.5
34.0	69.3	7.6	73.3	6.5	76.6	5.8	79.4	5.4	80.9	5.1
36.0	67.8	6.9	71.8	6.0	75.1	5.4	77.7	5.0	79.1	4.8
38.0	66.3	6.3	70.3	5.5	73.5	5.0	76.0	4.7	77.3	4.5
40.0	64.8	5.8	68.8	5.1	71.9	4.7	74.3	4.4	75.4	4.2
42.0	63.3	5.3	67.2	4.7	70.2	4.3	72.6	4.1	73.6	4.0
44.0	61.7	4.9	65.6	4.3	68.6	4.0	70.8	3.8	71.6	3.7
46.0	60.1	4.4	63.9	4.0	66.8	3.7	68.9	3.5	69.5	3.5
48.0	58.4	3.8	62.3	3.7	65.1	3.4	66.9	3.3		
50.0	56.6	3.3	60.5	3.4	63.3	3.2	64.9	3.0		
52.0	54.9	2.9	58.7	3.1	61.4	2.9	62.9	2.8		
54.0	53.0	2.5	56.8	2.7	59.4	2.7	60.7	2.6		
56.0	51.2	2.1	54.8	2.3	57.3	2.5	58.4	2.4		
58.0			52.8	2.0	55.1	2.1	56.0	2.2		
60.0					52.8	1.8	53.5	1.8		
危険角度(°)	49.5		51		51		51		67.5	
標準フック	12t									
フック質量(t)	0.42									
巻掛本数	1									

KATO KA-3000R

■ 定格総荷重表

● 55mブーム+2m+30mスーパーラフィングジブ

SA性能										
オフセット	0°		15°		30°		45°		60°	
作業半径 (m)	ブーム角度 (°)	荷重 (t)	ブーム角度 (°)	荷重 (t)	ブーム角度 (°)	荷重 (t)	ブーム角度 (°)	荷重 (t)	ブーム角度 (°)	荷重 (t)
9.0	84.8	8.0								
10.0	84.3	8.0								
11.0	83.8	8.0								
12.0	83.3	8.0								
14.0	82.3	8.0								
16.0	81.3	8.0								
18.0	80.2	8.0								
20.0	79.2	8.0	84.2	8.0						
22.0	78.2	8.0	83.1	8.0						
24.0	77.1	8.0	82.0	8.0						
26.0	76.1	8.0	80.9	8.0						
28.0	75.0	8.0	79.6	7.7	83.7	6.7				
30.0	73.9	8.0	78.3	7.1	82.3	6.2				
32.0	72.6	7.8	77.0	6.6	80.9	5.8	84.3	5.2		
34.0	71.2	7.1	75.7	6.0	79.5	5.3	82.8	4.9		
36.0	69.9	6.5	74.4	5.6	78.1	5.0	81.3	4.6	83.5	4.3
38.0	68.5	5.9	73.0	5.1	76.7	4.6	79.8	4.3	81.8	4.1
40.0	67.1	5.4	71.6	4.7	75.2	4.3	78.2	4.0	80.1	3.8
42.0	65.6	5.0	70.1	4.4	73.7	4.0	76.6	3.7	78.3	3.6
44.0	64.2	4.6	68.5	4.0	72.1	3.7	75.0	3.4	76.5	3.3
46.0	62.7	4.2	66.8	3.7	70.5	3.4	73.3	3.2	74.7	3.1
48.0	61.2	3.8	65.2	3.4	68.9	3.1	71.6	3.0	72.6	2.9
50.0	59.6	3.5	63.5	3.1	67.2	2.9	69.7	2.8	70.5	2.7
52.0	58.0	3.2	61.8	2.9	65.5	2.7	67.9	2.6	68.4	2.5
54.0	56.4	2.7	60.2	2.6	63.8	2.5	65.9	2.4		
56.0	54.7	2.4	58.5	2.4	62.0	2.3	63.9	2.2		
58.0	53.0	2.0	56.8	2.2	60.1	2.1	61.8	2.0		
60.0	51.2	1.7	55.0	2.0	58.2	1.9	59.6	1.9		
62.0			53.2	1.6	56.2	1.7	57.2	1.7		
64.0					54.1	1.5	54.8	1.5		
危険角度 (°)	49.5		51.5		52		52.5		67.5	
標準フック	12t									
フック質量 (t)	0.42									
巻掛本数	1									

● 55mブーム+2m+35mスーパーラフィングジブ

SA性能										
オフセット	0°		15°		30°		45°		60°	
作業半径 (m)	ブーム角度 (°)	荷重 (t)	ブーム角度 (°)	荷重 (t)	ブーム角度 (°)	荷重 (t)	ブーム角度 (°)	荷重 (t)	ブーム角度 (°)	荷重 (t)
10.0	84.7	6.5								
11.0	84.2	6.5								
12.0	83.7	6.5								
14.0	82.8	6.5								
16.0	81.9	6.5								
18.0	80.9	6.5								
20.0	80.0	6.5								
22.0	79.0	6.5	83.9	4.7						
24.0	78.0	6.5	82.8	4.4						
26.0	76.9	6.3	81.7	4.2						
28.0	75.8	5.9	80.5	4.0						
30.0	74.6	5.5	79.3	3.8	83.9	2.7				
32.0	73.4	5.2	78.1	3.7	82.7	2.6				
34.0	72.3	4.9	76.9	3.5	81.5	2.5	84.9	1.9		
36.0	71.1	4.6	75.7	3.3	80.2	2.4	83.5	1.8		
38.0	69.9	4.3	74.4	3.1	78.8	2.3	82.1	1.8		
40.0	68.7	4.1	73.2	3.0	77.5	2.2	80.7	1.7	83.6	1.4
42.0	67.4	3.9	71.9	2.8	76.1	2.1	79.3	1.7	82.0	1.4
44.0	66.1	3.8	70.6	2.7	74.7	2.0	77.8	1.6	80.4	1.4
46.0	64.8	3.6	69.2	2.6	73.3	2.0	76.3	1.6	78.7	1.4
48.0	63.5	3.4	67.9	2.5	71.8	1.9	74.8	1.5	76.9	1.4
50.0	62.1	3.2	66.5	2.4	70.3	1.8	73.2	1.5	75.1	1.3
52.0	60.7	3.0	65.1	2.3	68.8	1.8	71.6	1.5	73.2	1.3
54.0	59.2	2.8	63.6	2.2	67.3	1.7	69.9	1.4	71.2	1.3
56.0	57.7	2.5	62.2	2.1	65.7	1.7	68.2	1.4	69.2	1.3
58.0	56.1	2.2	60.6	2.0	64.0	1.6	66.4	1.4		
60.0	54.4	1.9	58.9	1.9	62.3	1.6	64.5	1.4		
62.0	52.8	1.6	57.2	1.7	60.6	1.5	62.6	1.4		
64.0	51.0	1.3	55.4	1.5	58.8	1.4	60.5	1.4		
66.0			53.6	1.3	56.9	1.3	58.4	1.3		
危険角度 (°)	49.5		52		55		56.5		67.5	
標準フック	12t									
フック質量 (t)	0.42									
巻掛本数	1									

● 55mブーム+2m+10.85mスーパーラフィングジブ

SB性能										
オフセット	5°		15°		30°		45°		60°	
作業半径 (m)	ブーム角度 (°)	荷重 (t)	ブーム角度 (°)	荷重 (t)	ブーム角度 (°)	荷重 (t)	ブーム角度 (°)	荷重 (t)	ブーム角度 (°)	荷重 (t)
8.0	84.7	18.0								
9.0	84.0	18.0								
10.0	83.4	18.0								
11.0	82.7	18.0	84.3	18.0						
12.0	82.0	18.0	83.7	18.0						
14.0	80.7	18.0	82.3	18.0	84.3	18.0				
16.0	79.3	18.0	80.9	18.0	82.7	17.5	84.1	15.8	84.8	13.8
18.0	77.9	18.0	79.5	18.0	81.0	15.9	82.3	14.5	83.2	13.8
20.0	76.5	18.0	77.8	16.3	79.3	14.5	80.6	13.3	81.3	12.7
22.0	74.8	16.2	76.1	14.8	77.6	13.2	78.8	12.3	79.4	11.8
24.0	73.0	14.6	74.3	13.4	75.8	12.1	77.0	11.3	77.5	11.0
26.0	71.2	13.0	72.5	12.2	74.1	11.1	75.2	10.5	75.6	10.2
28.0	69.3	11.5	70.7	11.2	72.3	10.2	73.3	9.7	73.5	9.5
30.0	67.5	10.1	68.9	10.2	70.4	9.4	71.3	9.0	71.5	8.9
32.0	65.6	8.9	66.9	9.0	68.5	8.7	69.2	8.3	69.3	8.3
34.0	63.7	7.9	64.8	7.9	66.5	8.0	67.2	7.7	67.1	7.7
36.0	61.8	6.9	62.8	7.0	64.5	7.1	65.0	7.1		
38.0	59.8	6.0	60.7	6.1	62.4	6.2	62.9	6.2		
40.0	57.6	5.2	58.5	5.3	60.5	5.4	60.5	5.5		
42.0	55.5	4.5	56.3	4.6	58.6	4.7	58.2	4.7		
44.0	53.0	3.3	54.0	3.8	56.6	4.0	55.7	4.1		
46.0					54.2	3.1	53.1	3.3		
危険角度 (°)	51		52		52		52		66	
標準フック	24t									
フック質量 (t)	0.88									
巻掛本数	2									

● 55mブーム+2m+15mスーパーラフィングジブ

SB性能										
オフセット	0°		15°		30°		45°		60°	
作業半径 (m)	ブーム角度 (°)	荷重 (t)	ブーム角度 (°)	荷重 (t)	ブーム角度 (°)	荷重 (t)	ブーム角度 (°)	荷重 (t)	ブーム角度 (°)	荷重 (t)
7.0	84.5	12.0								
8.0	83.8	12.0								
9.0	83.2	12.0								
10.0	82.6	12.0								
11.0	81.9	12.0								
12.0	81.3	12.0	84.4	12.0						
14.0	80.0	12.0	83.1	12.0						
16.0	78.7	12.0	81.8	12.0	84.4	12.0				
18.0	77.4	12.0	80.5	12.0	83.0	12.0				
20.0	76.0	12.0	79.1	12.0	81.6	12.0	83.5	11.6	84.7	10.2
22.0	74.7	12.0	77.8	12.0	80.0	11.8	81.8	10.8	83.0	10.2
24.0	73.3	12.0	76.4	12.0	78.4	10.9	80.1	10.0	81.2	9.5
26.0	71.9	12.0	74.8	11.2	76.7	10.0	78.4	9.3	79.4	8.9
28.0	70.2	11.8	73.1	10.3	75.1	9.2	76.6	8.6	77.5	8.3
30.0	68.5	10.6	71.4	9.4	73.4	8.5	74.8	8.0	75.6	7.8
32.0	66.8	9.4	69.7	8.6	71.6	7.9	73.0	7.4	73.7	7.3
34.0	65.1	8.3	68.0	8.0	69.9	7.3	71.1	6.9	71.7	6.8
36.0	63.3	7.4	66.3	7.3	68.0	6.8	69.2	6.5	69.7	6.4
38.0	61.5	6.5	64.5	6.7	66.2	6.3	67.2	6.0	67.6	6.0
40.0	59.6	5.7	62.5	5.9	64.2	5.8	65.1	5.6		
42.0	57.7	5.0	60.6	5.2	62.1	5.3	63.0	5.2		
44.0	55.7	4.4	58.6	4.5	60.0	4.7	60.8	4.7		
46.0	53.5	3.3	56.5	3.9	57.8	4.1	58.5	4.1		
48.0			54.2	3.2	55.6	3.5	56.1	3.5		
50.0					53.1	2.8	53.6	3.0		
危険角度 (°)	51.5		52		52		52		66	
標準フック	12t									
フック質量 (t)	0.42									
巻掛本数	1									

KA-3000R

KATO KA-3000R

■定格総荷重表

●55mブーム+2m+20mスーパーラフィングジブ

SB性能										
オフセット	0°		15°		30°		45°		60°	
作業半径 (m)	ブーム角度 (°)	荷重 (t)	ブーム角度 (°)	荷重 (t)	ブーム角度 (°)	荷重 (t)	ブーム角度 (°)	荷重 (t)	ブーム角度 (°)	荷重 (t)
8.0	84.5	11.0								
9.0	84.0	11.0								
10.0	83.4	11.0								
11.0	82.8	11.0								
12.0	82.2	11.0								
14.0	81.1	11.0	84.7	11.0						
16.0	79.9	11.0	83.5	11.0						
18.0	78.6	11.0	82.3	11.0						
20.0	77.4	11.0	81.0	11.0	84.5	11.0				
22.0	76.1	11.0	79.7	11.0	83.0	10.3				
24.0	74.8	11.0	78.5	11.0	81.5	9.5	83.9	8.6		
26.0	73.5	11.0	76.9	10.0	79.9	8.8	82.3	8.0	83.9	7.5
28.0	72.0	10.8	75.4	9.2	78.4	8.1	80.6	7.4	82.2	7.1
30.0	70.5	9.8	73.9	8.4	76.8	7.5	78.9	6.9	80.4	6.6
32.0	69.0	8.9	72.3	7.8	75.2	7.0	77.2	6.5	78.6	6.2
34.0	67.5	8.1	70.7	7.1	73.6	6.5	75.4	6.0	76.7	5.8
36.0	65.9	7.4	69.1	6.6	71.9	6.0	73.7	5.6	74.8	5.5
38.0	64.3	6.8	67.5	6.1	70.1	5.6	71.8	5.2	72.9	5.1
40.0	62.6	6.0	65.8	5.6	68.3	5.1	70.0	4.9	70.8	4.8
42.0	60.8	5.3	64.0	5.1	66.5	4.8	68.1	4.6	68.7	4.5
44.0	59.0	4.7	62.2	4.7	64.7	4.4	66.1	4.2		
46.0	57.2	4.1	60.4	4.3	62.8	4.1	64.1	4.0		
48.0	55.2	3.4	58.5	3.8	60.8	3.8	62.0	3.7		
50.0	53.1	2.5	56.5	3.3	58.7	3.5	59.8	3.4		
52.0			54.4	2.7	56.5	3.0	57.4	3.0		
54.0					54.3	2.5	55.0	2.6		
危険角度(°)	51.5		52.5		52.5		52.5		67	
標準フック	12t									
フック質量(t)	0.42									
巻掛本数	1									

●55mブーム+2m+25mスーパーラフィングジブ

SB性能										
オフセット	0°		15°		30°		45°		60°	
作業半径 (m)	ブーム角度 (°)	荷重 (t)	ブーム角度 (°)	荷重 (t)	ブーム角度 (°)	荷重 (t)	ブーム角度 (°)	荷重 (t)	ブーム角度 (°)	荷重 (t)
9.0	84.4	9.0								
10.0	83.9	9.0								
11.0	83.3	9.0								
12.0	82.7	9.0								
14.0	81.6	9.0								
16.0	80.5	9.0	84.9	9.0						
18.0	79.3	9.0	83.8	9.0						
20.0	78.2	9.0	82.6	9.0						
22.0	77.0	9.0	81.4	9.0						
24.0	75.8	9.0	80.2	9.0	84.1	8.5				
26.0	74.6	9.0	79.0	9.0	82.6	7.9				
28.0	73.4	9.0	77.6	8.4	81.2	7.3	84.1	6.6		
30.0	72.2	9.0	76.2	7.7	79.7	6.8	82.5	6.2	84.3	5.8
32.0	70.8	8.3	74.8	7.1	78.1	6.3	81.0	5.8	82.6	5.5
34.0	69.3	7.6	73.3	6.5	76.6	5.8	79.4	5.4	80.9	5.1
36.0	67.8	6.9	71.8	6.0	75.1	5.4	77.7	5.0	79.1	4.8
38.0	66.3	6.3	70.3	5.5	73.5	5.0	76.0	4.7	77.3	4.5
40.0	64.8	5.8	68.8	5.1	71.9	4.7	74.3	4.4	75.4	4.2
42.0	63.3	5.3	67.2	4.7	70.2	4.3	72.6	4.1	73.6	4.0
44.0	61.7	4.9	65.6	4.3	68.6	4.0	70.8	3.8	71.6	3.7
46.0	60.1	4.4	63.9	4.0	66.8	3.7	68.9	3.5	69.5	3.5
48.0	58.4	3.8	62.3	3.7	65.1	3.4	66.9	3.3		
50.0	56.6	3.3	60.5	3.4	63.3	3.2	64.9	3.0		
52.0	54.7	2.7	58.7	3.1	61.4	2.9	62.9	2.8		
54.0	52.6	1.9	56.8	2.7	59.4	2.7	60.7	2.6		
56.0			54.8	2.3	57.3	2.5	58.4	2.4		
58.0					55.1	2.1	56.0	2.2		
60.0							53.5	1.8		
危険角度(°)	51.5		53		53		53		67.5	
標準フック	12t									
フック質量(t)	0.42									
巻掛本数	1									

●55mブーム+2m+30mスーパーラフィングジブ

SB性能										
オフセット	0°		15°		30°		45°		60°	
作業半径 (m)	ブーム角度 (°)	荷重 (t)	ブーム角度 (°)	荷重 (t)	ブーム角度 (°)	荷重 (t)	ブーム角度 (°)	荷重 (t)	ブーム角度 (°)	荷重 (t)
9.0	84.8	8.0								
10.0	84.3	8.0								
11.0	83.8	8.0								
12.0	83.3	8.0								
14.0	82.3	8.0								
16.0	81.3	8.0								
18.0	80.2	8.0								
20.0	79.2	8.0	84.2	8.0						
22.0	78.0	8.0	83.1	8.0						
24.0	77.1	8.0	82.0	8.0						
26.0	76.1	8.0	80.9	8.0						
28.0	75.0	8.0	79.6	7.7	83.7	6.7				
30.0	73.9	8.0	78.3	7.1	82.3	6.2				
32.0	72.6	7.8	77.0	6.6	80.9	5.8	84.3	5.2		
34.0	71.2	7.1	75.7	6.0	79.5	5.3	82.8	4.9		
36.0	69.9	6.5	74.4	5.6	78.1	5.0	81.3	4.6	83.5	4.3
38.0	68.5	5.9	73.0	5.1	76.7	4.6	79.8	4.3	81.8	4.1
40.0	67.1	5.4	71.6	4.7	75.2	4.3	78.2	4.0	80.1	3.8
42.0	65.6	5.0	70.1	4.4	73.7	4.0	76.6	3.7	78.3	3.6
44.0	64.2	4.6	68.5	4.0	72.1	3.7	75.0	3.4	76.5	3.3
46.0	62.7	4.2	66.8	3.7	70.5	3.4	73.3	3.2	74.7	3.1
48.0	61.2	3.8	65.2	3.4	68.9	3.1	71.6	3.0	72.6	2.9
50.0	59.6	3.5	63.5	3.1	67.2	2.9	69.7	2.8	70.5	2.7
52.0	58.0	3.2	61.8	2.9	65.5	2.7	67.9	2.6	68.4	2.5
54.0	56.4	2.7	60.2	2.6	63.8	2.5	65.9	2.4		
56.0	54.5	2.0	58.5	2.4	62.0	2.3	63.9	2.2		
58.0	52.5	1.3	56.8	2.2	60.1	2.1	61.8	2.0		
60.0			55.0	1.9	58.2	1.9	59.6	1.9		
62.0					56.2	1.7	57.2	1.7		
64.0					54.1	1.5	54.8	1.5		
危険角度(°)	51.5		53.5		53.5		53.5		57.5	
標準フック	12t									
フック質量(t)	0.42									
巻掛本数	1									

●55mブーム+2m+35mスーパーラフィングジブ

SB性能										
オフセット	0°		15°		30°		45°		60°	
作業半径 (m)	ブーム角度 (°)	荷重 (t)	ブーム角度 (°)	荷重 (t)	ブーム角度 (°)	荷重 (t)	ブーム角度 (°)	荷重 (t)	ブーム角度 (°)	荷重 (t)
10.0	84.7	6.5								
11.0	84.2	6.5								
12.0	83.7	6.5								
14.0	82.8	6.5								
16.0	81.9	6.5								
18.0	80.9	6.5								
20.0	80.0	6.5								
22.0	79.0	6.5	83.9	4.7						
24.0	78.0	6.5	82.8	4.4						
26.0	76.9	6.3	81.7	4.2						
28.0	75.8	5.9	80.5	4.0						
30.0	74.6	5.5	79.3	3.8	83.9	2.7				
32.0	73.4	5.2	78.1	3.7	82.7	2.6				
34.0	72.3	4.9	76.9	3.5	81.5	2.5	84.9	1.9		
36.0	71.1	4.6	75.7	3.3	80.2	2.4	83.5	1.8		
38.0	69.9	4.3	74.4	3.1	78.8	2.3	82.1	1.8		
40.0	68.7	4.1	73.2	3.0	77.5	2.2	80.7	1.7	83.6	1.4
42.0	67.4	3.9	71.9	2.8	76.1	2.1	79.3	1.7	82.0	1.4
44.0	66.1	3.8	70.6	2.7	74.7	2.0	77.8	1.6	80.4	1.4
46.0	64.8	3.6	69.2	2.6	73.3	2.0	76.3	1.6	78.7	1.4
48.0	63.5	3.4	67.9	2.5	71.8	1.9	74.8	1.5	76.9	1.4
50.0	62.1	3.2	66.5	2.4	70.3	1.8	73.2	1.5	75.1	1.3
52.0	60.7	3.0	65.1	2.3	68.8	1.8	71.6	1.5	73.2	1.3
54.0	59.2	2.8	63.6	2.2	67.3	1.7	69.9	1.4	71.2	1.3
56.0	57.7	2.5	62.2	2.1	65.7	1.7	68.2	1.4	69.2	1.3
58.0	56.0	2.1	60.6	2.0	64.0	1.6	66.4	1.4		
60.0	54.1	1.5	58.9	1.9	62.3	1.6	64.5	1.4		
62.0			57.2	1.7	60.6	1.5	62.6	1.4		
64.0			55.4	1.5	58.8	1.4	60.5	1.4		
66.0					56.9	1.3	58.4	1.3		
危険角度(°)	52.5		53.5		55		56.5		67.5	
標準フック	12t									
フック質量(t)	0.42									
巻掛本数	1									

KATO KA-3000R

■定格総荷重表

●55mブーム+2m+10.85mスーパーラフィングジブ

SC性能										
オフセット	5°		15°		30°		45°		60°	
作業半径 (m)	ブーム角度 (°)	荷重 (t)	ブーム角度 (°)	荷重 (t)	ブーム角度 (°)	荷重 (t)	ブーム角度 (°)	荷重 (t)	ブーム角度 (°)	荷重 (t)
8.0	84.7	18.0								
9.0	84.0	18.0								
10.0	83.4	18.0								
11.0	82.7	18.0	84.3	18.0						
12.0	82.0	18.0	83.7	18.0						
14.0	80.7	18.0	82.3	18.0	84.3	18.0				
16.0	79.3	18.0	80.9	18.0	82.7	17.5	84.1	15.8	84.8	13.8
18.0	77.9	18.0	79.5	18.0	81.0	15.9	82.3	14.5	83.2	13.8
20.0	76.5	18.0	77.8	16.3	79.3	14.5	80.6	13.3	81.3	12.7
22.0	74.8	16.2	76.1	14.8	77.6	13.2	78.8	12.3	79.4	11.8
24.0	73.0	14.6	74.3	13.4	75.8	12.1	77.0	11.3	77.5	11.0
26.0	71.2	13.0	72.5	12.2	74.1	11.1	75.2	10.5	75.6	10.2
28.0	69.3	11.5	70.7	11.2	72.3	10.2	73.3	9.7	73.5	9.5
30.0	67.5	10.1	68.9	10.2	70.4	9.4	71.3	9.0	71.5	8.9
32.0	65.6	8.9	66.9	9.0	68.5	8.7	69.2	8.3	69.3	8.3
34.0	63.7	7.9	64.8	7.9	66.5	8.0	67.2	7.7	67.1	7.7
36.0	61.8	6.9	62.8	7.0	64.5	7.1	65.0	7.1		
38.0	59.7	5.7	60.7	6.1	62.4	6.2	62.9	6.2		
40.0	57.4	4.4	58.4	4.9	60.5	5.4	60.5	5.5		
42.0	55.1	3.1	56.1	3.6	58.3	4.2	58.1	4.5		
44.0					55.9	2.9	55.5	3.2		
危険角度(°)	53		54		54		54		66	
標準フック	24t									
フック質量(t)	0.88									
巻掛本数	2									

●55mブーム+2m+15mスーパーラフィングジブ

SC性能										
オフセット	0°		15°		30°		45°		60°	
作業半径 (m)	ブーム角度 (°)	荷重 (t)	ブーム角度 (°)	荷重 (t)	ブーム角度 (°)	荷重 (t)	ブーム角度 (°)	荷重 (t)	ブーム角度 (°)	荷重 (t)
7.0	84.5	12.0								
8.0	83.8	12.0								
9.0	83.2	12.0								
10.0	82.6	12.0								
11.0	81.9	12.0								
12.0	81.3	12.0	84.4	12.0						
14.0	80.0	12.0	83.1	12.0						
16.0	78.7	12.0	81.8	12.0	84.4	12.0				
18.0	77.4	12.0	80.5	12.0	83.0	12.0				
20.0	76.0	12.0	79.1	12.0	81.6	12.0	83.5	11.6	84.7	10.2
22.0	74.7	12.0	77.8	12.0	80.0	11.8	81.8	10.8	83.0	10.2
24.0	73.3	12.0	76.4	12.0	78.4	10.9	80.1	10.0	81.2	9.5
26.0	71.9	12.0	74.8	11.2	76.7	10.0	78.4	9.3	79.4	8.9
28.0	70.2	11.8	73.1	10.3	75.1	9.2	76.6	8.6	77.5	8.3
30.0	68.5	10.6	71.4	9.4	73.4	8.5	74.8	8.0	75.6	7.8
32.0	66.8	9.4	69.7	8.6	71.6	7.9	73.0	7.4	73.7	7.3
34.0	65.1	8.3	68.0	8.0	69.9	7.3	71.1	6.9	71.7	6.8
36.0	63.3	7.4	66.3	7.3	68.0	6.8	69.2	6.5	69.7	6.4
38.0	61.5	6.5	64.5	6.7	66.2	6.3	67.2	6.0	67.6	6.0
40.0	59.5	5.4	62.5	5.9	64.2	5.8	65.1	5.6		
42.0	57.5	4.2	60.6	5.2	62.1	5.3	63.0	5.2		
44.0	55.3	3.0	58.4	4.1	60.0	4.7	60.8	4.7		
46.0			56.1	3.0	57.7	3.7	58.5	4.1		
48.0					55.3	2.6	56.0	2.9		
危険角度(°)	53.5		54		54		54		66	
標準フック	12t									
フック質量(t)	0.42									
巻掛本数	1									

●55mブーム+2m+20mスーパーラフィングジブ

SC性能										
オフセット	0°		15°		30°		45°		60°	
作業半径 (m)	ブーム角度 (°)	荷重 (t)	ブーム角度 (°)	荷重 (t)	ブーム角度 (°)	荷重 (t)	ブーム角度 (°)	荷重 (t)	ブーム角度 (°)	荷重 (t)
8.0	84.5	11.0								
9.0	84.0	11.0								
10.0	83.4	11.0								
11.0	82.8	11.0								
12.0	82.2	11.0								
14.0	81.1	11.0	84.7	11.0						
16.0	79.9	11.0	83.5	11.0						
18.0	78.6	11.0	82.3	11.0						
20.0	77.4	11.0	81.0	11.0	84.5	11.0				
22.0	76.1	11.0	79.7	11.0	83.0	10.3				
24.0	74.8	11.0	78.5	11.0	81.5	9.5	83.9	8.6		
26.0	73.5	11.0	76.9	10.0	79.9	8.8	82.3	8.0	83.9	7.5
28.0	72.0	10.8	75.4	9.2	78.4	8.1	80.6	7.4	82.2	7.1
30.0	70.5	9.8	73.9	8.4	76.8	7.5	78.9	6.9	80.4	6.6
32.0	69.0	8.9	72.3	7.8	75.2	7.0	77.2	6.5	78.6	6.2
34.0	67.5	8.1	70.7	7.1	73.6	6.5	75.4	6.0	76.7	5.8
36.0	65.9	7.4	69.1	6.6	71.9	6.0	73.7	5.6	74.8	5.5
38.0	64.3	6.8	67.5	6.1	70.1	5.6	71.8	5.2	72.9	5.1
40.0	62.6	6.0	65.8	5.6	68.3	5.1	70.0	4.9	70.8	4.8
42.0	60.8	5.3	64.0	5.1	66.5	4.8	68.1	4.6	68.7	4.5
44.0	58.9	4.2	62.2	4.7	64.7	4.4	66.1	4.2		
46.0	56.9	3.1	60.4	4.3	62.8	4.1	64.1	4.0		
48.0	54.8	2.2	58.3	3.4	60.8	3.8	62.0	3.7		
50.0			56.2	2.4	58.6	3.3	59.8	3.4		
52.0					56.3	2.4	57.4	2.8		
危険角度(°)	53.5		54.5		54.5		55		67	
標準フック	12t									
フック質量(t)	0.42									
巻掛本数	1									

●55mブーム+2m+25mスーパーラフィングジブ

SC性能										
オフセット	0°		15°		30°		45°		60°	
作業半径 (m)	ブーム角度 (°)	荷重 (t)	ブーム角度 (°)	荷重 (t)	ブーム角度 (°)	荷重 (t)	ブーム角度 (°)	荷重 (t)	ブーム角度 (°)	荷重 (t)
9.0	84.4	9.0								
10.0	83.9	9.0								
11.0	83.3	9.0								
12.0	82.7	9.0								
14.0	81.6	9.0								
16.0	80.5	9.0	84.9	9.0						
18.0	79.3	9.0	83.8	9.0						
20.0	78.2	9.0	82.6	9.0						
22.0	77.0	9.0	81.4	9.0						
24.0	75.8	9.0	80.2	9.0	84.1	8.5				
26.0	74.6	9.0	79.0	9.0	82.6	7.9				
28.0	73.4	9.0	77.6	8.4	81.2	7.3	84.1	6.6		
30.0	72.2	9.0	76.2	7.7	79.7	6.8	82.5	6.2	84.3	5.8
32.0	70.8	8.3	74.8	7.1	78.1	6.3	81.0	5.8	82.6	5.5
34.0	69.3	7.6	73.3	6.5	76.6	5.8	79.4	5.4	80.9	5.1
36.0	67.8	6.9	71.8	6.0	75.1	5.4	77.7	5.0	79.1	4.8
38.0	66.3	6.3	70.3	5.5	73.5	5.0	76.0	4.7	77.3	4.5
40.0	64.8	5.8	68.8	5.1	71.9	4.7	74.3	4.4	75.4	4.2
42.0	63.3	5.3	67.2	4.7	70.2	4.3	72.6	4.1	73.6	4.0
44.0	61.7	4.9	65.6	4.3	68.6	4.0	70.8	3.8	71.6	3.7
46.0	59.9	4.1	63.9	4.0	66.8	3.7	68.9	3.5	69.5	3.5
48.0	58.1	3.2	62.3	3.7	65.1	3.4	66.9	3.3		
50.0	56.1	2.3	60.5	3.4	63.3	3.2	64.9	3.0		
52.0			58.6	2.8	61.4	2.9	62.9	2.8		
54.0			56.5	2.0	59.4	2.7	60.7	2.6		
56.0					57.2	2.1	58.4	2.4		
58.0							55.9	1.8		
危険角度(°)	54.5		55		55		55		67.5	
標準フック	12t									
フック質量(t)	0.42									
巻掛本数	1									

KA-3000R

KATO KA-3000R

■ 定格総荷重表

● 55mブーム+2m+30mスーパーラフィングジブ

SC性能										
オフセット	0°		15°		30°		45°		60°	
作業半径 (m)	ブーム角度 (°)	荷重 (t)	ブーム角度 (°)	荷重 (t)	ブーム角度 (°)	荷重 (t)	ブーム角度 (°)	荷重 (t)	ブーム角度 (°)	荷重 (t)
9.0	84.8	8.0								
10.0	84.3	8.0								
11.0	83.8	8.0								
12.0	83.3	8.0								
14.0	82.3	8.0								
16.0	81.3	8.0								
18.0	80.2	8.0								
20.0	79.2	8.0	84.2	8.0						
22.0	78.2	8.0	83.1	8.0						
24.0	77.1	8.0	82.0	8.0						
26.0	76.1	8.0	80.9	8.0						
28.0	75.0	8.0	79.6	7.7	83.7	6.7				
30.0	73.9	8.0	78.3	7.1	82.3	6.2				
32.0	72.6	7.8	77.0	6.6	80.9	5.8	84.3	5.2		
34.0	71.2	7.1	75.7	6.0	79.5	5.3	82.8	4.9		
36.0	69.9	6.5	74.4	5.6	78.1	5.0	81.3	4.6	83.5	4.3
38.0	68.5	5.9	73.0	5.1	76.7	4.6	79.8	4.3	81.8	4.1
40.0	67.1	5.4	71.6	4.7	75.2	4.3	78.2	4.0	80.1	3.8
42.0	65.6	5.0	70.1	4.4	73.7	4.0	76.6	3.7	78.3	3.6
44.0	64.2	4.6	68.5	4.0	72.1	3.7	75.0	3.4	76.5	3.3
46.0	62.7	4.2	66.8	3.7	70.5	3.4	73.3	3.2	74.7	3.1
48.0	61.2	3.8	65.2	3.4	68.9	3.1	71.6	3.0	72.6	2.9
50.0	59.5	3.2	63.5	3.1	67.2	2.9	69.7	2.8	70.5	2.7
52.0	57.6	2.3	61.8	2.9	65.5	2.7	67.9	2.6	68.4	2.5
54.0	55.8	1.6	60.2	2.6	63.8	2.5	65.9	2.4		
56.0			58.5	2.3	62.0	2.3	63.9	2.2		
58.0			56.5	1.6	60.1	2.1	61.8	2.0		
60.0					58.2	1.9	59.6	1.9		
62.0							57.2	1.7		
危険角度(°)	54.5		55		56		56		67.5	
標準フック	12t									
フック質量(t)	0.42									
巻掛本数	1									

● 55mブーム+2m+35mスーパーラフィングジブ

SC性能										
オフセット	0°		15°		30°		45°		60°	
作業半径 (m)	ブーム角度 (°)	荷重 (t)	ブーム角度 (°)	荷重 (t)	ブーム角度 (°)	荷重 (t)	ブーム角度 (°)	荷重 (t)	ブーム角度 (°)	荷重 (t)
10.0	84.7	6.5								
11.0	84.2	6.5								
12.0	83.7	6.5								
14.0	82.8	6.5								
16.0	81.9	6.5								
18.0	80.9	6.5								
20.0	80.0	6.5								
22.0	79.0	6.5	83.9	4.7						
24.0	78.0	6.5	82.8	4.4						
26.0	76.9	6.3	81.7	4.2						
28.0	75.8	5.9	80.5	4.0						
30.0	74.6	5.5	79.3	3.8	83.9	2.7				
32.0	73.4	5.2	78.1	3.7	82.7	2.6				
34.0	72.3	4.9	76.9	3.5	81.5	2.5	84.9	1.9		
36.0	71.1	4.6	75.7	3.3	80.2	2.4	83.5	1.8		
38.0	69.9	4.3	74.4	3.1	78.8	2.3	82.1	1.8		
40.0	68.7	4.1	73.2	3.0	77.5	2.2	80.7	1.7	83.6	1.4
42.0	67.4	3.9	71.9	2.8	76.1	2.1	79.3	1.7	82.0	1.4
44.0	66.1	3.8	70.6	2.7	74.7	2.0	77.8	1.6	80.4	1.4
46.0	64.8	3.6	69.2	2.6	73.3	2.0	76.3	1.6	78.7	1.4
48.0	63.5	3.4	67.9	2.5	71.8	1.9	74.8	1.5	76.9	1.4
50.0	62.1	3.2	66.5	2.4	70.3	1.8	73.2	1.5	75.1	1.3
52.0	60.7	3.0	65.1	2.3	68.8	1.8	71.6	1.5	73.2	1.3
54.0	59.0	2.4	63.6	2.2	67.3	1.7	69.9	1.4	71.2	1.3
56.0	57.2	1.7	62.2	2.1	65.7	1.7	68.2	1.4	69.2	1.3
58.0			60.6	2.0	64.0	1.6	66.4	1.4		
60.0			58.9	1.9	62.3	1.6	64.5	1.4		
62.0			57.0	1.3	60.6	1.5	62.6	1.4		
64.0					58.8	1.4	60.5	1.4		
66.0							58.4	1.3		
危険角度(°)	55.5		56		57		57		67.5	
標準フック	12t									
フック質量(t)	0.42									
巻掛本数	1									

KA-3000R

KATO KA-3000R

■作業範囲図

●ブーム・ヘビーリフトジブ

- Ⓐ 14.4mブーム + 4.4m + 13m ヘビーリフトジブ (オフセット10°)
- Ⓑ 14.4mブーム + 4.4m + 22m ヘビーリフトジブ (オフセット10°)
- Ⓒ 14.4mブーム + 4.4m + 31m ヘビーリフトジブ (オフセット10°)
- Ⓓ 14.4mブーム + 4.4m + 40m ヘビーリフトジブ (オフセット10°)
- Ⓔ 14.4mブーム + 4.4m + 47m ヘビーリフトジブ (オフセット10°)
- Ⓕ 14.4mブーム + 4.4m + 54m ヘビーリフトジブ (オフセット10°)
- Ⓖ 14.4mブーム + 4.4m + 22m ヘビーリフトジブ (オフセット60°)
- Ⓗ 14.4mブーム + 4.4m + 31m ヘビーリフトジブ (オフセット60°)
- Ⓙ 14.4mブーム + 4.4m + 40m ヘビーリフトジブ (オフセット60°)
- Ⓚ 14.4mブーム + 4.4m + 47m ヘビーリフトジブ (オフセット60°)
- Ⓛ 14.4mブーム + 4.4m + 54m ヘビーリフトジブ (オフセット60°)
- Ⓜ 53.9mブーム + 4.4m + 22m ヘビーリフトジブ (オフセット10°)
- Ⓝ 53.9mブーム + 4.4m + 31m ヘビーリフトジブ (オフセット10°)
- Ⓞ 53.9mブーム + 4.4m + 40m ヘビーリフトジブ (オフセット10°)
- Ⓟ 53.9mブーム + 4.4m + 47m ヘビーリフトジブ (オフセット10°)
- Ⓠ 53.9mブーム + 4.4m + 54m ヘビーリフトジブ (オフセット10°)
- Ⓡ 53.9mブーム + 4.4m + 22m ヘビーリフトジブ (オフセット60°)
- Ⓢ 53.9mブーム + 4.4m + 31m ヘビーリフトジブ (オフセット60°)
- Ⓣ 53.9mブーム + 4.4m + 40m ヘビーリフトジブ (オフセット60°)
- Ⓤ 53.9mブーム + 4.4m + 47m ヘビーリフトジブ (オフセット45°)
- Ⓥ 53.9mブーム + 4.4m + 54m ヘビーリフトジブ (オフセット30°)

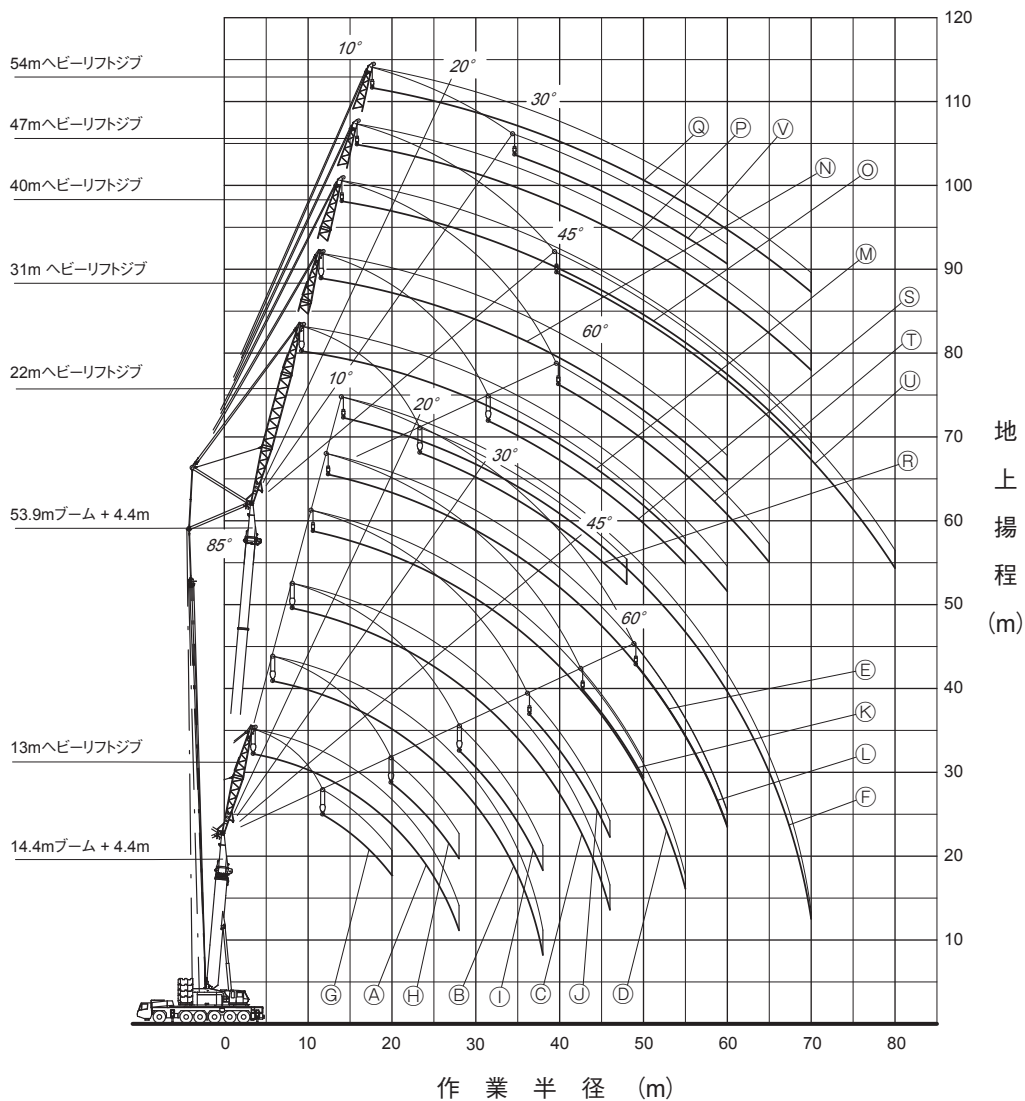

(注) 1. 本図は、ブームおよびヘビーリフトジブのたわみを含んでいません。
 2. HA性能時のものを示しています。

縮尺 1/900

KA-3000R

KATO KA-3000R

■ 定格総荷重表

● 14.4mブーム+4.4m+13mヘビーリフトジブ

HA性能					
オフセット	10°	20°	30°	45°	60°
作業半径(m)	荷重 (t)	荷重 (t)	荷重 (t)	荷重 (t)	荷重 (t)
6.0	84.0				
7.0	84.0				
8.0	84.0	84.0			
9.0	84.0	80.7			
10.0	82.8	76.6	66.0		
11.0	78.3	72.9	63.4		
12.0	72.8	69.5	61.1	51.3	
14.0	63.4	63.8	56.9	48.5	34.6
16.0	56.1	56.5	53.4	46.2	33.7
18.0	50.2	50.7	50.3	44.4	33.1
20.0	45.1	45.8	46.3	42.9	32.9
22.0	40.2	40.8	41.3	41.8	
24.0	36.1	36.5	36.9	37.1	
26.0	32.6	32.9	33.1		
28.0	29.6	29.7			
危険角度(°)	10	20	30	45	60
フック種類	150t				
フック質量(t)	1.90				
掛数	8				

● 19.55mブーム+4.4m+13mヘビーリフトジブ

HA性能					
オフセット	10°	20°	30°	45°	60°
作業半径(m)	荷重 (t)	荷重 (t)	荷重 (t)	荷重 (t)	荷重 (t)
6.0	77.0				
7.0	77.0				
8.0	77.0	77.0			
9.0	77.0	77.0			
10.0	77.0	77.0	68.1		
11.0	77.0	76.1	65.7		
12.0	76.9	73.9	63.5		
14.0	65.1	66.7	59.5	50.8	37.7
16.0	56.0	57.3	56.2	48.6	36.8
18.0	48.7	49.8	50.9	46.8	36.1
20.0	42.8	43.7	44.6	45.2	35.6
22.0	37.8	38.7	39.4	40.2	35.4
24.0	33.7	34.4	35.0	35.6	
26.0	30.2	30.7	31.2	31.6	
28.0	27.1	27.5	27.9	28.1	
30.0	24.4	24.8	25.0		
32.0	22.0	22.2			
34.0	17.6				
危険角度(°)	10	20	30	45	60
フック種類	150t				
フック質量(t)	1.90				
掛数	8				

● 23.6mブーム+4.4m+13mヘビーリフトジブ

HA性能					
オフセット	10°	20°	30°	45°	60°
作業半径(m)	荷重 (t)	荷重 (t)	荷重 (t)	荷重 (t)	荷重 (t)
7.0	64.0				
8.0	64.0				
9.0	64.0	64.0			
10.0	64.0	64.0			
11.0	64.0	64.0	64.0		
12.0	64.0	64.0	64.0		
14.0	63.9	64.0	61.4	51.8	
16.0	54.8	56.3	57.7	49.9	38.8
18.0	47.5	48.8	50.0	48.2	38.1
20.0	41.5	42.7	43.7	45.0	37.5
22.0	36.6	37.6	38.5	39.5	37.2
24.0	32.4	33.3	34.0	34.8	35.2
26.0	28.8	29.6	30.2	30.8	
28.0	25.7	26.4	26.9	27.3	
30.0	23.0	23.6	23.9	24.2	
32.0	20.5	20.9	21.2		
34.0	18.3	18.6	18.7		
36.0	16.3	16.5			
38.0	12.5				
危険角度(°)	10	20	30	45	60
フック種類	83t				
フック質量(t)	1.00				
掛数	6				

● 32mブーム+4.4m+13mヘビーリフトジブ

HA性能					
オフセット	10°	20°	30°	45°	60°
作業半径(m)	荷重 (t)	荷重 (t)	荷重 (t)	荷重 (t)	荷重 (t)
8.0	45.0				
9.0	45.0				
10.0	45.0	40.4			
11.0	44.3	39.8			
12.0	43.6	39.3	35.6		
14.0	42.3	38.3	34.9	30.1	
16.0	41.2	37.5	34.2	29.7	25.5
18.0	40.2	36.8	33.7	29.4	25.4
20.0	39.4	36.2	33.2	29.2	25.3
22.0	36.4	35.7	32.9	29.0	25.3
24.0	32.2	33.2	32.7	29.0	25.3
26.0	28.7	29.5	30.3	29.0	25.3
28.0	25.6	26.3	27.0	27.7	25.3
30.0	22.8	23.5	24.1	24.7	
32.0	20.3	20.9	21.4	21.9	
34.0	18.0	18.6	19.0	19.4	
36.0	16.1	16.5	16.9	17.1	
38.0	14.3	14.7	14.9		
40.0	12.7	13.0	13.2		
42.0	11.3	11.5	11.5		
44.0	9.9	10.1			
46.0	7.6				
危険角度(°)	10	20	30	45	60
フック種類	83t				
フック質量(t)	1.00				
掛数	4				

● 14.4mブーム+4.4m+13mヘビーリフトジブ

HB性能					
オフセット	10°	20°	30°	45°	60°
作業半径(m)	荷重 (t)	荷重 (t)	荷重 (t)	荷重 (t)	荷重 (t)
6.0	84.0				
7.0	84.0				
8.0	84.0	84.0			
9.0	84.0	80.7			
10.0	82.8	76.6	66.0		
11.0	78.3	72.9	63.4		
12.0	72.8	69.5	61.1	51.3	
14.0	63.4	63.8	56.9	48.5	34.6
16.0	56.1	56.6	53.4	46.2	33.7
18.0	49.3	50.2	50.3	44.4	33.1
20.0	43.6	44.3	44.9	42.9	32.9
22.0	38.8	39.4	39.9	40.3	
24.0	34.7	35.2	35.6	35.8	
26.0	31.0	31.3	31.5		
28.0	27.9	28.0			
危険角度(°)	10	20	30	45	60
フック種類	150t				
フック質量(t)	1.90				
掛数	8				

● 19.55mブーム+4.4m+13mヘビーリフトジブ

HB性能					
オフセット	10°	20°	30°	45°	60°
作業半径(m)	荷重 (t)	荷重 (t)	荷重 (t)	荷重 (t)	荷重 (t)
6.0	77.0				
7.0	77.0				
8.0	77.0	77.0			
9.0	77.0	77.0			
10.0	77.0	77.0	68.1		
11.0	77.0	76.1	65.7		
12.0	74.4	73.9	63.5		
14.0	62.9	64.5	59.5	50.8	37.7
16.0	54.0	55.4	56.2	48.6	36.8
18.0	47.0	48.1	49.2	46.8	36.1
20.0	41.2	42.2	43.1	44.1	35.6
22.0	36.4	37.2	38.0	38.8	35.4
24.0	32.1	32.9	33.5	34.2	
26.0	28.4	29.0	29.5	30.0	
28.0	25.2	25.7	26.1	26.3	
30.0	22.5	22.8	23.0		
32.0	20.1	20.3			
34.0	17.6				
危険角度(°)	10	20	30	45	60
フック種類	150t				
フック質量(t)	1.90				
掛数	8				

KATO KA-3000R

■ 定格総荷重表

● 23.6mブーム+4.4m+13mヘビーリフトジブ

HB性能					
オフセット	10°	20°	30°	45°	60°
作業半径(m)	荷重 (t)	荷重 (t)	荷重 (t)	荷重 (t)	荷重 (t)
7.0	64.0				
8.0	64.0				
9.0	64.0	64.0			
10.0	64.0	64.0			
11.0	64.0	64.0	64.0		
12.0	64.0	64.0	64.0		
14.0	61.8	63.6	61.4	51.8	
16.0	52.8	54.4	55.8	49.9	38.8
18.0	45.7	47.1	48.3	48.2	38.1
20.0	40.0	41.1	42.1	43.4	37.5
22.0	35.1	36.1	37.0	38.1	37.2
24.0	30.7	31.6	32.4	33.4	33.7
26.0	26.9	27.7	28.4	29.1	
28.0	23.7	24.4	25.0	25.5	
30.0	21.0	21.5	21.9	22.2	
32.0	18.6	19.0	19.3		
34.0	16.5	16.8	16.9		
36.0	14.6	14.8			
38.0	12.5				
危険角度(°)	10	20	30	45	60
フック種類	83t				
フック質量(t)	1.00				
掛数	6				

● 32mブーム+4.4m+13mヘビーリフトジブ

HB性能					
オフセット	10°	20°	30°	45°	60°
作業半径(m)	荷重 (t)	荷重 (t)	荷重 (t)	荷重 (t)	荷重 (t)
8.0	45.0				
9.0	45.0				
10.0	45.0	40.4			
11.0	44.3	39.8			
12.0	43.6	39.3	35.6		
14.0	42.3	38.3	34.8	30.1	
16.0	41.2	37.5	34.2	29.7	25.5
18.0	40.2	36.8	33.7	29.4	25.4
20.0	39.4	36.2	33.2	29.2	25.3
22.0	35.0	35.7	32.9	29.0	25.3
24.0	30.5	31.6	32.5	29.0	25.3
26.0	26.8	27.7	28.5	29.0	25.3
28.0	23.6	24.4	25.1	25.9	25.3
30.0	20.8	21.5	22.1	22.7	
32.0	18.4	19.0	19.5	20.0	
34.0	16.2	16.8	17.2	17.6	
36.0	14.4	14.8	15.2	15.4	
38.0	12.7	13.0	13.3		
40.0	11.2	11.5	11.6		
42.0	9.8	10.0	10.1		
44.0	8.6	8.7			
46.0	7.4				
危険角度(°)	10	20	30	45	60
フック種類	83t				
フック質量(t)	1.00				
掛数	4				

● 14.4mブーム+4.4m+13mヘビーリフトジブ

HC性能					
オフセット	10°	20°	30°	45°	60°
作業半径(m)	荷重 (t)	荷重 (t)	荷重 (t)	荷重 (t)	荷重 (t)
6.0	84.0				
7.0	84.0				
8.0	84.0	84.0			
9.0	84.0	80.7			
10.0	82.8	76.6	66.0		
11.0	78.3	72.9	63.4		
12.0	72.8	69.5	61.1	51.3	
14.0	63.0	63.8	56.9	48.5	34.6
16.0	54.4	55.5	53.4	46.2	33.7
18.0	47.6	48.4	49.2	44.4	33.1
20.0	41.4	42.2	42.9	42.9	32.9
22.0	36.4	37.0	37.5	38.0	
24.0	32.2	32.7	33.0	33.3	
26.0	28.7	29.0	29.2		
28.0	25.7	25.8			
危険角度(°)	10	20	30	45	60
フック種類	150t				
フック質量(t)	1.90				
掛数	8				

● 19.55mブーム+4.4m+13mヘビーリフトジブ

HC性能					
オフセット	10°	20°	30°	45°	60°
作業半径(m)	荷重 (t)	荷重 (t)	荷重 (t)	荷重 (t)	荷重 (t)
6.0	77.0				
7.0	77.0				
8.0	77.0	77.0			
9.0	77.0	77.0			
10.0	77.0	77.0	68.1		
11.0	77.0	76.1	65.7		
12.0	71.9	73.8	63.5		
14.0	60.8	62.4	59.5	50.8	37.7
16.0	52.1	53.5	54.7	48.6	36.8
18.0	45.0	46.3	47.5	46.8	36.1
20.0	38.8	39.9	40.8	42.0	35.6
22.0	33.7	34.6	35.4	36.4	35.4
24.0	29.5	30.3	30.9	31.6	
26.0	26.0	26.6	27.1	27.6	
28.0	23.0	23.5	23.9	24.1	
30.0	20.4	20.8	21.0		
32.0	18.2	18.4			
34.0	16.2				
危険角度(°)	10	20	30	45	60
フック種類	150t				
フック質量(t)	1.90				
掛数	8				

● 23.6mブーム+4.4m+13mヘビーリフトジブ

HC性能					
オフセット	10°	20°	30°	45°	60°
作業半径(m)	荷重 (t)	荷重 (t)	荷重 (t)	荷重 (t)	荷重 (t)
7.0	64.0				
8.0	64.0				
9.0	64.0	64.0			
10.0	64.0	64.0			
11.0	64.0	64.0	64.0		
12.0	64.0	64.0	64.0		
14.0	59.6	61.4	61.4	51.8	
16.0	50.9	52.5	53.9	49.9	38.8
18.0	43.6	45.1	46.5	48.1	38.1
20.0	37.4	38.7	39.8	41.3	37.5
22.0	32.3	33.4	34.4	35.6	36.2
24.0	28.1	29.1	29.9	30.8	31.2
26.0	24.6	25.4	26.1	26.8	
28.0	21.6	22.2	22.8	23.3	
30.0	18.9	19.5	19.9	20.2	
32.0	16.7	17.1	17.4		
34.0	14.7	15.0	15.1		
36.0	12.9	13.1			
38.0	11.3				
危険角度(°)	10	20	30	45	60
フック種類	83t				
フック質量(t)	1.00				
掛数	6				

● 32mブーム+4.4m+13mヘビーリフトジブ

HC性能					
オフセット	10°	20°	30°	45°	60°
作業半径(m)	荷重 (t)	荷重 (t)	荷重 (t)	荷重 (t)	荷重 (t)
8.0	45.0				
9.0	45.0				
10.0	45.0	40.4			
11.0	44.3	39.8			
12.0	43.6	39.3	35.6		
14.0	42.3	38.3	34.8	30.1	
16.0	41.2	37.5	34.2	29.7	25.5
18.0	40.2	36.8	33.7	29.4	25.4
20.0	37.2	36.2	33.2	29.2	25.3
22.0	32.2	33.4	32.9	29.0	25.3
24.0	28.0	29.0	30.0	29.0	25.3
26.0	24.4	25.3	26.2	27.1	25.3
28.0	21.4	22.2	22.9	23.7	24.0
30.0	18.8	19.5	20.1	20.7	
32.0	16.5	17.1	17.6	18.1	
34.0	14.4	15.0	15.4	15.8	
36.0	12.7	13.1	13.5	13.7	
38.0	11.1	11.4	11.7		
40.0	9.6	9.9	10.1		
42.0	8.3	8.6	8.6		
44.0	7.2	7.3			
46.0	6.1				
危険角度(°)	10	20	30	45	60
フック種類	83t				
フック質量(t)	1.00				
掛数	4				

KA-3000R

KATO KA-3000R

■ 定格総荷重表

● 14.4mブーム+4.4m+22mヘビーリフトジブ

HA性能					
オフセット	10°	20°	30°	45°	60°
作業半径(m)	荷重 (t)	荷重 (t)	荷重 (t)	荷重 (t)	荷重 (t)
8.0	54.0				
9.0	54.0				
10.0	54.0				
11.0	54.0				
12.0	54.0	52.8			
14.0	54.0	47.6			
16.0	50.5	43.4	38.0		
18.0	45.6	39.8	35.4		
20.0	41.6	36.8	33.1	28.2	
22.0	38.2	34.3	31.1	26.9	19.6
24.0	35.3	32.1	29.4	25.8	19.1
26.0	32.9	30.2	28.0	24.9	18.7
28.0	30.8	28.5	26.7	24.1	18.5
30.0	28.7	27.1	25.6	23.5	
32.0	26.4	25.9	24.8	23.1	
34.0	24.3	24.6	24.1		
36.0	22.4	22.6	22.8		
38.0	18.4				
危険角度(°)	10	20	30	45	60
フック種類	83t				
フック質量(t)	1.00				
掛数	6				

● 19.55mブーム+4.4m+22mヘビーリフトジブ

HA性能					
オフセット	10°	20°	30°	45°	60°
作業半径(m)	荷重 (t)	荷重 (t)	荷重 (t)	荷重 (t)	荷重 (t)
9.0	50.0				
10.0	50.0				
11.0	50.0				
12.0	50.0				
14.0	50.0	49.8			
16.0	50.0	45.7	39.1		
18.0	49.9	42.2	36.6		
20.0	45.2	39.2	34.4	29.4	
22.0	40.2	36.6	32.6	28.2	
24.0	36.0	34.4	30.9	27.1	20.9
26.0	32.4	32.4	29.4	26.2	20.5
28.0	29.3	30.3	28.2	25.4	20.2
30.0	26.6	27.5	27.0	24.7	20.0
32.0	24.2	25.0	25.7	24.2	20.0
34.0	22.1	22.7	23.3	23.8	
36.0	20.0	20.6	21.1	21.6	
38.0	18.2	18.7	19.1		
40.0	16.6	17.0	17.2		
42.0	15.2	15.4			
危険角度(°)	10	20	30	45	60
フック種類	83t				
フック質量(t)	1.00				
掛数	6				

● 23.6mブーム+4.4m+22mヘビーリフトジブ

HA性能					
オフセット	10°	20°	30°	45°	60°
作業半径(m)	荷重 (t)	荷重 (t)	荷重 (t)	荷重 (t)	荷重 (t)
10.0	45.0				
11.0	45.0				
12.0	45.0				
14.0	45.0	45.0			
16.0	45.0	45.0	42.2		
18.0	45.0	45.0	39.5		
20.0	44.2	43.3	37.3	31.2	
22.0	39.2	40.4	35.3	29.9	
24.0	34.9	36.4	33.5	28.8	22.2
26.0	31.3	32.6	31.9	27.9	21.7
28.0	28.2	29.4	30.5	27.0	21.4
30.0	25.4	26.5	27.5	26.3	21.1
32.0	23.0	24.0	24.8	25.6	21.0
34.0	20.8	21.7	22.4	23.3	21.0
36.0	18.7	19.5	20.2	20.9	
38.0	16.9	17.6	18.1	18.6	
40.0	15.3	15.8	16.3		
42.0	13.8	14.2	14.5		
44.0	12.5	12.8	12.9		
46.0	11.2	11.4			
危険角度(°)	10	20	30	45	60
フック種類	83t				
フック質量(t)	1.00				
掛数	4				

● 32mブーム+4.4m+22mヘビーリフトジブ

HA性能					
オフセット	10°	20°	30°	45°	60°
作業半径(m)	荷重 (t)	荷重 (t)	荷重 (t)	荷重 (t)	荷重 (t)
11.0	30.0				
12.0	30.0				
14.0	30.0	30.0			
16.0	30.0	29.4			
18.0	30.0	28.5	25.5		
20.0	30.0	27.6	24.8		
22.0	29.7	26.9	24.3	20.6	
24.0	28.8	26.2	23.8	20.2	16.9
26.0	28.1	25.6	23.3	19.9	16.7
28.0	27.4	25.1	22.9	19.7	16.6
30.0	24.7	24.7	22.6	19.5	16.6
32.0	22.3	23.4	22.3	19.4	16.6
34.0	20.1	21.1	22.1	19.3	16.6
36.0	18.0	19.0	19.9	19.3	16.6
38.0	16.2	17.1	17.8	18.7	16.6
40.0	14.6	15.4	16.0	16.7	
42.0	13.1	13.8	14.4	14.9	
44.0	11.8	12.4	12.9	13.3	
46.0	10.6	11.1	11.5		
48.0	9.5	9.9	10.2		
50.0	8.4	8.8	9.0		
55.0	5.3				
危険角度(°)	10	20	30	45	60
フック種類	83t				
フック質量(t)	1.00				
掛数	4				

● 40mブーム+4.4m+22mヘビーリフトジブ

HA性能					
オフセット	10°	20°	30°	45°	60°
作業半径(m)	荷重 (t)	荷重 (t)	荷重 (t)	荷重 (t)	荷重 (t)
12.0	20.0				
14.0	20.0				
16.0	20.0	20.0			
18.0	20.0	20.0			
20.0	20.0	20.0	20.0		
22.0	20.0	20.0	20.0		
24.0	20.0	20.0	20.0	18.4	
26.0	20.0	20.0	20.0	18.2	15.2
28.0	20.0	20.0	20.0	18.0	15.1
30.0	20.0	20.0	20.0	17.8	15.0
32.0	20.0	20.0	20.0	17.7	15.0
34.0	18.8	19.6	20.0	17.6	15.0
36.0	17.3	18.0	18.7	17.5	15.0
38.0	15.9	16.6	17.2	17.5	15.0
40.0	14.3	15.2	15.9	16.6	15.0
42.0	12.9	13.7	14.4	15.2	15.0
44.0	11.5	12.3	12.9	13.5	
46.0	10.3	11.0	11.5	12.0	
48.0	9.2	9.8	10.2	10.7	
50.0	8.1	8.6	9.1	9.4	
55.0	5.9	6.2	6.4		
60.0	4.0	4.1			
危険角度(°)	15	20	30	45	60
フック種類	24t				
フック質量(t)	0.88				
掛数	2				

● 45mブーム+4.4m+22mヘビーリフトジブ

HA性能					
オフセット	10°	20°	30°	45°	60°
作業半径(m)	荷重 (t)	荷重 (t)	荷重 (t)	荷重 (t)	荷重 (t)
12.0	16.0				
14.0	16.0				
16.0	16.0	16.0			
18.0	16.0	16.0			
20.0	16.0	16.0	16.0		
22.0	16.0	16.0	16.0		
24.0	16.0	16.0	16.0	16.0	
26.0	16.0	16.0	16.0	15.8	13.2
28.0	16.0	16.0	16.0	15.7	13.1
30.0	16.0	16.0	16.0	15.5	13.0
32.0	16.0	16.0	16.0	15.4	13.0
34.0	16.0	16.0	16.0	15.3	13.0
36.0	15.5	16.0	16.0	15.2	13.0
38.0	14.3	15.0	15.6	15.2	13.0
40.0	13.1	13.8	14.4	15.1	13.0
42.0	12.0	12.6	13.2	13.9	13.0
44.0	11.0	11.6	12.1	12.7	13.0
46.0	10.0	10.6	11.1	11.6	
48.0	8.9	9.6	10.1	10.6	
50.0	7.9	8.5	9.0	9.4	
55.0	5.6	6.1	6.4	6.6	
60.0	3.7	4.0	4.2		
危険角度(°)	25	26	30	45	60
フック種類	24t				
フック質量(t)	0.88				
掛数	2				

KATO KA-3000R

■ 定格総荷重表

● 50mブーム+4.4m+22mヘビーリフトジブ

HA性能					
オフセット	10°	20°	30°	45°	60°
作業半径(m)	荷重 (t)	荷重 (t)	荷重 (t)	荷重 (t)	荷重 (t)
14.0	11.0				
16.0	11.0				
18.0	11.0	11.0			
20.0	11.0	11.0	11.0		
22.0	11.0	11.0	11.0		
24.0	11.0	11.0	11.0	9.5	
26.0	11.0	11.0	11.0	9.4	
28.0	11.0	11.0	11.0	9.3	7.6
30.0	11.0	11.0	11.0	9.2	7.6
32.0	11.0	11.0	10.9	9.2	7.6
34.0	11.0	11.0	10.8	9.1	7.6
36.0	11.0	11.0	10.7	9.1	7.6
38.0	11.0	11.0	10.6	9.1	7.6
40.0	11.0	11.0	10.6	9.1	7.6
42.0	10.2	10.8	10.5	9.1	7.6
44.0	9.3	9.9	10.3	9.1	7.6
46.0	8.5	9.0	9.5	9.1	7.6
48.0	7.8	8.3	8.7	9.1	
50.0	7.1	7.5	7.9	8.3	
55.0	5.4	5.9	6.2	6.5	
60.0	3.5	3.9	4.2		
危険角度(°)	33	35	36	45	60
フック種類	24t				
フック質量(t)	0.88				
掛数	2				

● 53.9mブーム+4.4m+22mヘビーリフトジブ

HA性能					
オフセット	10°	20°	30°	45°	60°
作業半径(m)	荷重 (t)	荷重 (t)	荷重 (t)	荷重 (t)	荷重 (t)
14.0	9.0				
16.0	9.0				
18.0	9.0	9.0			
20.0	9.0	9.0			
22.0	9.0	9.0	8.8		
24.0	9.0	9.0	8.6		
26.0	9.0	9.0	8.5	6.9	
28.0	9.0	9.0	8.3	6.9	5.5
30.0	9.0	9.0	8.2	6.8	5.5
32.0	9.0	9.0	8.1	6.8	5.5
34.0	9.0	9.0	8.1	6.7	5.5
36.0	9.0	9.0	8.0	6.7	5.5
38.0	9.0	8.9	8.0	6.7	5.5
40.0	9.0	8.8	7.9	6.7	5.5
42.0	8.7	8.8	7.9	6.7	5.5
44.0	7.9	8.5	7.9	6.7	5.5
46.0	7.2	7.7	7.9	6.7	5.5
48.0	6.5	6.9	7.4	6.7	5.5
50.0	5.8	6.3	6.7	6.7	
55.0	4.4	4.8	5.1	5.4	
60.0	3.2	3.5	3.7	3.9	
危険角度(°)	38	40	41	45	60
フック種類	24t				
フック質量(t)	0.88				
掛数	2				

● 14.4mブーム+4.4m+22mヘビーリフトジブ

HB性能					
オフセット	10°	20°	30°	45°	60°
作業半径(m)	荷重 (t)	荷重 (t)	荷重 (t)	荷重 (t)	荷重 (t)
8.0	54.0				
9.0	54.0				
10.0	54.0				
11.0	54.0				
12.0	54.0	52.8			
14.0	54.0	47.6			
16.0	50.5	43.4	38.0		
18.0	45.6	39.8	35.4		
20.0	41.6	36.8	33.1	28.2	
22.0	38.2	34.3	31.1	26.9	19.6
24.0	35.3	32.1	29.4	25.8	19.1
26.0	32.9	30.2	28.0	24.8	18.7
28.0	30.0	28.5	26.7	24.1	18.5
30.0	27.2	27.1	25.6	23.5	
32.0	24.7	25.3	24.8	23.1	
34.0	22.6	23.0	23.3		
36.0	20.7	21.0	21.1		
38.0	18.4				
危険角度(°)	10	20	30	45	60
フック種類	83t				
フック質量(t)	1.00				
掛数	6				

● 19.55mブーム+4.4m+22mヘビーリフトジブ

HB性能					
オフセット	10°	20°	30°	45°	60°
作業半径(m)	荷重 (t)	荷重 (t)	荷重 (t)	荷重 (t)	荷重 (t)
9.0	50.0				
10.0	50.0				
11.0	50.0				
12.0	50.0				
14.0	50.0	49.8			
16.0	50.0	45.7	39.1		
18.0	49.5	42.2	36.6		
20.0	43.6	39.2	34.4	29.4	
22.0	38.8	36.6	32.6	28.2	
24.0	34.7	34.4	30.9	27.1	20.9
26.0	30.9	32.1	29.4	26.2	20.5
28.0	27.7	28.7	28.2	25.4	20.2
30.0	24.9	25.8	26.7	24.7	20.0
32.0	22.4	23.2	24.0	24.2	20.0
34.0	20.3	20.9	21.6	22.3	
36.0	18.3	18.9	19.4	19.9	
38.0	16.6	17.1	17.5		
40.0	15.1	15.4	15.7		
42.0	13.7	13.9			
危険角度(°)	10	20	30	45	60
フック種類	83t				
フック質量(t)	1.00				
掛数	6				

● 23.6mブーム+4.4m+22mヘビーリフトジブ

HB性能					
オフセット	10°	20°	30°	45°	60°
作業半径(m)	荷重 (t)	荷重 (t)	荷重 (t)	荷重 (t)	荷重 (t)
10.0	45.0				
11.0	45.0				
12.0	45.0				
14.0	45.0	45.0			
16.0	45.0	45.0	42.2		
18.0	45.0	45.0	39.5		
20.0	42.6	43.3	37.3	31.2	
22.0	37.7	39.4	35.3	29.9	
24.0	33.5	35.1	33.5	28.8	22.2
26.0	29.7	31.2	31.9	27.9	21.7
28.0	26.4	27.7	28.9	27.0	21.4
30.0	23.6	24.8	25.8	26.3	21.1
32.0	21.1	22.2	23.1	24.2	21.0
34.0	19.0	19.9	20.7	21.6	21.0
36.0	17.0	17.8	18.5	19.2	
38.0	15.3	16.0	16.5	17.0	
40.0	13.8	14.3	14.7		
42.0	12.4	12.8	13.1		
44.0	11.1	11.4	11.5		
46.0	9.9	10.0			
危険角度(°)	10	20	30	45	60
フック種類	83t				
フック質量(t)	1.00				
掛数	4				

● 32mブーム+4.4m+22mヘビーリフトジブ

HB性能					
オフセット	10°	20°	30°	45°	60°
作業半径(m)	荷重 (t)	荷重 (t)	荷重 (t)	荷重 (t)	荷重 (t)
11.0	30.0				
12.0	30.0				
14.0	30.0	30.0			
16.0	30.0	29.4			
18.0	30.0	28.5	25.5		
20.0	30.0	27.6	24.8		
22.0	29.7	26.9	24.3	20.6	
24.0	28.8	26.2	23.8	20.2	16.9
26.0	28.1	25.6	23.3	19.9	16.7
28.0	25.7	25.1	22.9	19.7	16.6
30.0	22.9	24.2	22.6	19.5	16.6
32.0	20.4	21.6	22.3	19.4	16.6
34.0	18.3	19.3	20.3	19.3	16.6
36.0	16.3	17.3	18.2	19.2	16.6
38.0	14.6	15.5	16.2	17.1	16.6
40.0	13.1	13.8	14.5	15.2	
42.0	11.7	12.3	12.9	13.5	
44.0	10.4	11.0	11.5	11.9	
46.0	9.2	9.7	10.1		
48.0	8.2	8.6	8.9		
50.0	7.2	7.5	7.7		
55.0	5.1				
危険角度(°)	10	20	30	45	60
フック種類	83t				
フック質量(t)	1.00				
掛数	4				

KA-3000R

KATO KA-3000R

■ 定格総荷重表

● 40mブーム+4.4m+22mヘビーリフトジブ

HB性能					
オフセット	10°	20°	30°	45°	60°
作業半径(m)	荷重 (t)	荷重 (t)	荷重 (t)	荷重 (t)	荷重 (t)
12.0	20.0				
14.0	20.0				
16.0	20.0	20.0			
18.0	20.0	20.0			
20.0	20.0	20.0	20.0		
22.0	20.0	20.0	20.0		
24.0	20.0	20.0	20.0	18.4	
26.0	20.0	20.0	20.0	18.2	15.2
28.0	20.0	20.0	20.0	18.0	15.1
30.0	20.0	20.0	20.0	17.8	15.0
32.0	20.0	20.0	20.0	17.7	15.0
34.0	18.0	19.2	20.0	17.6	15.0
36.0	16.1	17.2	18.2	17.5	15.0
38.0	14.4	15.4	16.2	17.3	15.0
40.0	12.8	13.7	14.5	15.4	15.0
42.0	11.4	12.2	12.9	13.7	14.0
44.0	10.1	10.9	11.5	12.2	
46.0	9.0	9.6	10.2	10.7	
48.0	7.9	8.5	9.0	9.4	
50.0	6.9	7.4	7.8	8.1	
55.0	4.8	5.1	5.3		
60.0	3.0	3.1			
危険角度(°)	19	20	30	45	60
フック種類	24t				
フック質量(t)	0.88				
掛数	2				

● 45mブーム+4.4m+22mヘビーリフトジブ

HB性能					
オフセット	10°	20°	30°	45°	60°
作業半径(m)	荷重 (t)	荷重 (t)	荷重 (t)	荷重 (t)	荷重 (t)
12.0	16.0				
14.0	16.0				
16.0	16.0	16.0			
18.0	16.0	16.0			
20.0	16.0	16.0	16.0		
22.0	16.0	16.0	16.0		
24.0	16.0	16.0	16.0	16.0	
26.0	16.0	16.0	16.0	15.8	13.2
28.0	16.0	16.0	16.0	15.7	13.1
30.0	16.0	16.0	16.0	15.5	13.0
32.0	16.0	16.0	16.0	15.4	13.0
34.0	16.0	16.0	16.0	15.3	13.0
36.0	15.5	16.0	16.0	15.2	13.0
38.0	14.1	15.0	15.6	15.2	13.0
40.0	12.5	13.5	14.4	15.1	13.0
42.0	11.1	12.0	12.8	13.7	13.0
44.0	9.9	10.7	11.4	12.1	12.4
46.0	8.7	9.4	10.1	10.7	
48.0	7.6	8.3	8.9	9.4	
50.0	6.6	7.2	7.7	8.2	
55.0	4.5	5.0	5.3	5.5	
60.0	2.7	3.0	3.2		
危険角度(°)	27	28	30	45	60
フック種類	24t				
フック質量(t)	0.88				
掛数	2				

● 50mブーム+4.4m+22mヘビーリフトジブ

HB性能					
オフセット	10°	20°	30°	45°	60°
作業半径(m)	荷重 (t)	荷重 (t)	荷重 (t)	荷重 (t)	荷重 (t)
14.0	11.0				
16.0	11.0				
18.0	11.0	11.0			
20.0	11.0	11.0	11.0		
22.0	11.0	11.0	11.0		
24.0	11.0	11.0	11.0	9.5	
26.0	11.0	11.0	11.0	9.4	
28.0	11.0	11.0	11.0	9.3	7.6
30.0	11.0	11.0	11.0	9.2	7.6
32.0	11.0	11.0	10.9	9.2	7.6
34.0	11.0	11.0	10.8	9.1	7.6
36.0	11.0	11.0	10.7	9.1	7.6
38.0	11.0	11.0	10.6	9.1	7.6
40.0	11.0	11.0	10.6	9.1	7.6
42.0	10.2	10.8	10.5	9.1	7.6
44.0	9.3	9.9	10.3	9.1	7.6
46.0	8.4	9.0	9.5	9.1	7.6
48.0	7.4	8.1	8.7	9.1	
50.0	6.4	7.1	7.6	8.2	
55.0	4.3	4.8	5.2	5.5	
60.0		2.9	3.2		
危険角度(°)	40	40	40	45	60
フック種類	24t				
フック質量(t)	0.88				
掛数	2				

● 53.9mブーム+4.4m+22mヘビーリフトジブ

HB性能					
オフセット	10°	20°	30°	45°	60°
作業半径(m)	荷重 (t)	荷重 (t)	荷重 (t)	荷重 (t)	荷重 (t)
14.0	9.0				
16.0	9.0				
18.0	9.0	9.0			
20.0	9.0	9.0			
22.0	9.0	9.0	8.8		
24.0	9.0	9.0	8.6		
26.0	9.0	9.0	8.5	6.9	
28.0	9.0	9.0	8.3	6.9	5.5
30.0	9.0	9.0	8.2	6.8	5.5
32.0	9.0	9.0	8.1	6.8	5.5
34.0	9.0	9.0	8.1	6.7	5.5
36.0	9.0	9.0	8.0	6.7	5.5
38.0	9.0	8.9	8.0	6.7	5.5
40.0	9.0	8.8	7.9	6.7	5.5
42.0	8.7	8.8	7.9	6.7	5.5
44.0	7.9	8.5	7.9	6.7	5.5
46.0	7.2	7.7	7.9	6.7	5.5
48.0	6.5	6.9	7.4	6.7	5.5
50.0	5.8	6.3	6.7	6.7	
55.0	4.1	4.6	5.1	5.4	
60.0		2.7	3.1	3.3	
危険角度(°)	44	44	44	45	60
フック種類	24t				
フック質量(t)	0.88				
掛数	2				

● 14.4mブーム+4.4m+22mヘビーリフトジブ

HC性能					
オフセット	10°	20°	30°	45°	60°
作業半径(m)	荷重 (t)	荷重 (t)	荷重 (t)	荷重 (t)	荷重 (t)
8.0	54.0				
9.0	54.0				
10.0	54.0				
11.0	54.0				
12.0	54.0	52.8			
14.0	54.0	47.6			
16.0	50.5	43.4	38.0		
18.0	45.6	39.8	35.4		
20.0	41.6	36.8	33.1	28.2	
22.0	38.2	34.3	31.1	26.9	19.6
24.0	34.4	32.1	29.4	25.8	19.1
26.0	30.8	30.2	28.0	24.8	18.7
28.0	27.8	28.5	26.7	24.1	18.5
30.0	25.1	25.8	25.6	23.5	
32.0	22.8	23.3	23.8	23.1	
34.0	20.8	21.2	21.5		
36.0	19.0	19.3	19.4		
38.0	17.4				
危険角度(°)	10	20	30	45	60
フック種類	83t				
フック質量(t)	1.00				
掛数	6				

● 19.55mブーム+4.4m+22mヘビーリフトジブ

HC性能					
オフセット	10°	20°	30°	45°	60°
作業半径(m)	荷重 (t)	荷重 (t)	荷重 (t)	荷重 (t)	荷重 (t)
9.0	50.0				
10.0	50.0				
11.0	50.0				
12.0	50.0				
14.0	50.0	49.8			
16.0	50.0	45.7	39.1		
18.0	47.8	42.2	36.6		
20.0	41.6	39.2	34.4	29.4	
22.0	36.4	36.6	32.6	28.2	
24.0	32.2	33.6	30.9	27.1	20.9
26.0	28.6	29.8	29.4	26.2	20.5
28.0	25.5	26.6	27.6	25.4	20.2
30.0	22.8	23.8	24.9	24.7	20.0
32.0	20.5	21.3	22.1	23.0	20.0
34.0	18.5	19.2	19.8	20.5	
36.0	16.6	17.2	17.7	18.2	
38.0	15.0	15.5	15.9		
40.0	13.6	13.9	14.1		
42.0	12.3	12.5			
危険角度(°)	10	20	30	45	60
フック種類	83t				
フック質量(t)	1.00				
掛数	6				



KATO KA-3000R

■ 定格総荷重表

● 23.6mブーム+4.4m+22mヘビーリフトジブ

HC性能					
オフセット	10°	20°	30°	45°	60°
作業半径(m)	荷重 (t)	荷重 (t)	荷重 (t)	荷重 (t)	荷重 (t)
10.0	45.0				
11.0	45.0				
12.0	45.0				
14.0	45.0				
16.0	45.0	45.0			
18.0	45.0	45.0	39.5		
20.0	40.5	42.6	37.3	31.2	
22.0	35.3	37.1	35.3	29.9	
24.0	31.0	32.6	33.5	28.8	22.2
26.0	27.4	28.8	30.2	27.9	21.7
28.0	24.3	25.6	26.8	27.0	21.4
30.0	21.6	22.7	23.8	25.1	21.1
32.0	19.2	20.2	21.2	22.3	21.0
34.0	17.2	18.1	18.9	19.8	20.2
36.0	15.3	16.1	16.8	17.5	
38.0	13.7	14.4	14.9	15.4	
40.0	12.2	12.8	13.2		
42.0	10.9	11.3	11.6		
44.0	9.7	10.0	10.1		
46.0	8.6	8.7			
危険角度(°)	10	20	30	45	60
フック種類			83t		
フック質量(t)			1.00		
掛数			4		

● 32mブーム+4.4m+22mヘビーリフトジブ

HC性能					
オフセット	10°	20°	30°	45°	60°
作業半径(m)	荷重 (t)	荷重 (t)	荷重 (t)	荷重 (t)	荷重 (t)
11.0	30.0				
12.0	30.0				
14.0	30.0		30.0		
16.0	30.0	29.4			
18.0	30.0	28.5	25.5		
20.0	30.0	27.6	24.8		
22.0	29.7	26.9	24.3	20.6	
24.0	28.8	26.2	23.8	20.2	16.9
26.0	26.6	25.6	23.3	19.9	16.7
28.0	23.5	25.0	22.9	19.7	16.6
30.0	20.9	22.2	22.6	19.5	16.6
32.0	18.5	19.7	20.8	19.4	16.6
34.0	16.5	17.5	18.5	19.3	16.6
36.0	14.6	15.6	16.5	17.5	16.6
38.0	13.0	13.9	14.6	15.5	15.8
40.0	11.5	12.3	13.0	13.7	
42.0	10.2	10.9	11.5	12.0	
44.0	9.0	9.6	10.1	10.5	
46.0	7.9	8.4	8.8		
48.0	6.9	7.3	7.6		
50.0	6.0	6.3	6.5		
55.0	4.0				
危険角度(°)	10	20	30	45	60
フック種類			83t		
フック質量(t)			1.00		
掛数			4		

● 40mブーム+4.4m+22mヘビーリフトジブ

HC性能					
オフセット	10°	20°	30°	45°	60°
作業半径(m)	荷重 (t)	荷重 (t)	荷重 (t)	荷重 (t)	荷重 (t)
12.0	20.0				
14.0	20.0				
16.0	20.0	20.0			
18.0	20.0	20.0			
20.0	20.0	20.0	20.0		
22.0	20.0	20.0	20.0		
24.0	20.0	20.0	20.0	18.4	
26.0	20.0	20.0	20.0	18.2	15.2
28.0	20.0	20.0	20.0	18.0	15.1
30.0	20.0	20.0	20.0	17.8	15.0
32.0	18.3	19.6	20.0	17.7	15.0
34.0	16.2	17.4	18.5	17.6	15.0
36.0	14.4	15.5	16.5	17.5	15.0
38.0	12.8	13.8	14.6	15.7	15.0
40.0	11.3	12.2	13.0	13.9	14.3
42.0	10.0	10.8	11.5	12.3	12.5
44.0	8.7	9.5	10.1	10.8	
46.0	7.6	8.3	8.9	9.4	
48.0	6.6	7.2	7.7	8.1	
50.0	5.7	6.2	6.6	6.9	
55.0	3.7	4.0	4.2		
危険角度(°)	26	27	30	45	60
フック種類			24t		
フック質量(t)			0.88		
掛数			2		

● 45mブーム+4.4m+22mヘビーリフトジブ

HC性能					
オフセット	10°	20°	30°	45°	60°
作業半径(m)	荷重 (t)	荷重 (t)	荷重 (t)	荷重 (t)	荷重 (t)
12.0	16.0				
14.0	16.0				
16.0	16.0	16.0			
18.0	16.0	16.0			
20.0	16.0	16.0	16.0		
22.0	16.0	16.0	16.0		
24.0	16.0	16.0	16.0	16.0	
26.0	16.0	16.0	16.0	15.8	13.2
28.0	16.0	16.0	16.0	15.7	13.1
30.0	16.0	16.0	16.0	15.5	13.0
32.0	16.0	16.0	16.0	15.4	13.0
34.0	16.0	16.0	16.0	15.3	13.0
36.0	14.1	15.3	16.0	15.2	13.0
38.0	12.5	13.5	14.5	15.2	13.0
40.0	11.0	12.0	12.8	13.8	13.0
42.0	9.7	10.6	11.3	12.2	12.6
44.0	8.5	9.3	10.0	10.8	11.0
46.0	7.4	8.1	8.7	9.4	
48.0	6.4	7.0	7.6	8.1	
50.0	5.4	6.0	6.5	7.0	
55.0	3.4	3.8	4.2	4.4	
危険角度(°)	38	40	42	45	60
フック種類			24t		
フック質量(t)			0.88		
掛数			2		

● 50mブーム+4.4m+22mヘビーリフトジブ

HC性能					
オフセット	10°	20°	30°	45°	60°
作業半径(m)	荷重 (t)	荷重 (t)	荷重 (t)	荷重 (t)	荷重 (t)
14.0	11.0				
16.0	11.0				
18.0	11.0	11.0			
20.0	11.0	11.0	11.0		
22.0	11.0	11.0	11.0		
24.0	11.0	11.0	11.0	9.5	
26.0	11.0	11.0	11.0	9.4	
28.0	11.0	11.0	11.0	9.3	7.6
30.0	11.0	11.0	11.0	9.2	7.6
32.0	11.0	11.0	10.9	9.2	7.6
34.0	11.0	11.0	10.8	9.1	7.6
36.0	11.0	11.0	10.7	9.1	7.6
38.0	11.0	11.0	10.6	9.1	7.6
40.0	10.8	11.0	10.6	9.1	7.6
42.0	9.4	10.4	10.5	9.1	7.6
44.0	8.2	9.1	9.8	9.1	7.6
46.0	7.1	7.9	8.6	9.1	7.6
48.0	6.1	6.8	7.5	8.1	
50.0	5.2	5.8	6.4	7.0	
55.0	3.1	3.7	4.1	4.4	
危険角度(°)	42	44	46	48	60
フック種類			24t		
フック質量(t)			0.88		
掛数			2		

● 53.9mブーム+4.4m+22mヘビーリフトジブ

HC性能					
オフセット	10°	20°	30°	45°	60°
作業半径(m)	荷重 (t)	荷重 (t)	荷重 (t)	荷重 (t)	荷重 (t)
14.0	9.0				
16.0	9.0				
18.0	9.0	9.0			
20.0	9.0	9.0			
22.0	9.0	9.0	8.8		
24.0	9.0	9.0	8.6		
26.0	9.0	9.0	8.5	6.9	
28.0	9.0	9.0	8.3	6.9	5.5
30.0	9.0	9.0	8.2	6.8	5.5
32.0	9.0	9.0	8.1	6.8	5.5
34.0	9.0	9.0	8.1	6.7	5.5
36.0	9.0	9.0	8.0	6.7	5.5
38.0	9.0	8.9	8.0	6.7	5.5
40.0	9.0	8.8	7.9	6.7	5.5
42.0	8.7	8.8	7.9	6.7	5.5
44.0	7.9	8.5	7.9	6.7	5.5
46.0	6.9	7.7	7.9	6.7	5.5
48.0	5.9	6.7	7.4	6.7	5.5
50.0	5.0	5.7	6.3	6.7	
55.0	3.0	3.5	4.0	4.5	
危険角度(°)	45	47	48	49	60
フック種類			24t		
フック質量(t)			0.88		
掛数			2		

KA-3000R

KATO KA-3000R

■定格総荷重表

●14.4mブーム+4.4m+31mヘビーリフトジブ

HA性能					
オフセット	10°	20°	30°	45°	60°
作業半径(m)	荷重 (t)	荷重 (t)	荷重 (t)	荷重 (t)	荷重 (t)
11.0	35.0				
12.0	35.0				
14.0	35.0				
16.0	34.5				
18.0	34.5	34.1			
20.0	34.5	31.6			
22.0	33.1	29.2	26.1		
24.0	30.4	27.1	24.5		
26.0	28.2	25.4	23.1	19.7	
28.0	26.2	23.8	21.8	18.8	
30.0	24.5	22.4	20.7	18.0	13.1
32.0	23.0	21.2	19.7	17.3	12.8
34.0	21.6	20.2	18.9	16.7	12.5
36.0	20.5	19.2	18.1	16.2	12.3
38.0	19.4	18.3	17.4	15.8	12.2
40.0	18.5	17.6	16.8	15.5	
42.0	17.6	16.9	16.4	15.4	
44.0	16.9	16.4	16.0		
46.0	16.2	16.0			
危険角度(°)	10	20	30	45	60
フック種類	83t				
フック質量(t)	1.00				
掛数	4				

●19.55mブーム+4.4m+31mヘビーリフトジブ

HA性能					
オフセット	10°	20°	30°	45°	60°
作業半径(m)	荷重 (t)	荷重 (t)	荷重 (t)	荷重 (t)	荷重 (t)
12.0	34.0				
14.0	34.0				
16.0	34.0				
18.0	34.0	34.0			
20.0	34.0	33.0			
22.0	34.0	30.6	26.8		
24.0	32.9	28.6	25.2		
26.0	30.5	26.8	23.9		
28.0	28.5	25.2	22.7	19.8	
30.0	26.6	23.9	21.6	19.0	
32.0	25.0	22.6	20.6	18.4	14.0
34.0	23.5	21.5	19.8	17.8	13.7
36.0	21.6	20.5	19.0	17.3	13.5
38.0	19.8	19.6	18.3	16.8	13.3
40.0	18.1	18.8	17.7	16.4	13.3
42.0	16.7	17.4	17.1	16.1	
44.0	15.3	15.9	16.5	15.9	
46.0	14.1	14.6	15.0	15.4	
48.0	13.0	13.3	13.7		
50.0	11.9	12.2			
危険角度(°)	10	20	30	45	60
フック種類	83t				
フック質量(t)	1.00				
掛数	4				

●23.6mブーム+4.4m+31mヘビーリフトジブ

HA性能					
オフセット	10°	20°	30°	45°	60°
作業半径(m)	荷重 (t)	荷重 (t)	荷重 (t)	荷重 (t)	荷重 (t)
12.0	30.0				
14.0	30.0				
16.0	30.0				
18.0	30.0	30.0			
20.0	30.0	30.0			
22.0	30.0	30.0	27.2		
24.0	30.0	29.6	25.8		
26.0	30.0	27.8	24.4		
28.0	29.6	26.3	23.3	20.0	
30.0	26.9	24.9	22.2	19.3	
32.0	24.4	23.6	21.3	18.6	14.8
34.0	22.3	22.5	20.4	18.1	14.5
36.0	20.3	21.5	19.6	17.6	14.2
38.0	18.4	19.5	18.9	17.1	14.0
40.0	16.8	17.8	18.3	16.7	13.9
42.0	15.3	16.2	17.0	16.4	13.9
44.0	13.9	14.7	15.5	16.1	
46.0	12.7	13.4	14.0	14.7	
48.0	11.6	12.2	12.7	13.2	
50.0	10.5	11.0	11.4		
55.0	8.3	8.4			
危険角度(°)	10	20	30	45	60
フック種類	83t				
フック質量(t)	1.00				
掛数	4				

●32mブーム+4.4m+31mヘビーリフトジブ

HA性能					
オフセット	10°	20°	30°	45°	60°
作業半径(m)	荷重 (t)	荷重 (t)	荷重 (t)	荷重 (t)	荷重 (t)
14.0	20.0				
16.0	20.0				
18.0	20.0				
20.0	20.0	20.0			
22.0	20.0	20.0			
24.0	20.0	20.0	19.6		
26.0	20.0	20.0	19.1		
28.0	20.0	20.0	18.6		
30.0	20.0	20.0	18.2	15.3	
32.0	20.0	19.6	17.8	15.0	
34.0	20.0	19.2	17.4	14.8	12.2
36.0	19.8	18.7	17.1	14.6	12.1
38.0	19.9	18.4	16.8	14.4	12.0
40.0	16.2	17.4	16.6	14.3	12.0
42.0	14.7	15.8	16.4	14.2	12.0
44.0	13.4	14.4	15.3	14.1	12.0
46.0	12.1	13.0	13.8	14.1	12.0
48.0	11.0	11.8	12.5	13.4	
50.0	9.9	10.7	11.3	12.0	
55.0	7.6	8.1	8.6		
60.0	5.7	6.0	6.2		
危険角度(°)	15	20	30	45	60
フック種類	24t				
フック質量(t)	0.88				
掛数	2				

●40mブーム+4.4m+31mヘビーリフトジブ

HA性能					
オフセット	10°	20°	30°	45°	60°
作業半径(m)	荷重 (t)	荷重 (t)	荷重 (t)	荷重 (t)	荷重 (t)
16.0	14.0				
18.0	14.0				
20.0	14.0	14.0			
22.0	14.0	14.0			
24.0	14.0	14.0	14.0		
26.0	14.0	14.0	14.0		
28.0	14.0	14.0	14.0		
30.0	14.0	14.0	14.0	13.4	
32.0	14.0	14.0	14.0	13.2	
34.0	14.0	14.0	14.0	13.0	10.5
36.0	14.0	14.0	14.0	12.8	10.5
38.0	14.0	14.0	14.0	12.7	10.4
40.0	14.0	14.0	14.0	12.5	10.4
42.0	14.0	14.0	14.0	12.4	10.3
44.0	12.7	13.8	14.0	12.4	10.3
46.0	11.5	12.5	13.5	12.3	10.3
48.0	10.3	11.3	12.2	12.3	10.3
50.0	9.3	10.2	11.0	11.9	10.3
55.0	7.0	7.7	8.3	8.9	
60.0	5.1	5.6	6.0	6.4	
65.0	3.5	3.8	4.1		
危険角度(°)	25	27	30	45	60
フック種類	24t				
フック質量(t)	0.88				
掛数	2				

●45mブーム+4.4m+31mヘビーリフトジブ

HA性能					
オフセット	10°	20°	30°	45°	60°
作業半径(m)	荷重 (t)	荷重 (t)	荷重 (t)	荷重 (t)	荷重 (t)
16.0	12.0				
18.0	12.0				
20.0	12.0	12.0			
22.0	12.0	12.0			
24.0	12.0	12.0			
26.0	12.0	12.0	12.0		
28.0	12.0	12.0	12.0		
30.0	12.0	12.0	12.0	11.5	
32.0	12.0	12.0	12.0	11.3	
34.0	12.0	12.0	12.0	11.2	9.0
36.0	12.0	12.0	12.0	11.0	8.9
38.0	12.0	12.0	12.0	10.9	8.9
40.0	12.0	12.0	12.0	10.8	8.8
42.0	12.0	12.0	12.0	10.7	8.8
44.0	11.6	12.0	12.0	10.6	8.8
46.0	10.6	11.4	12.0	10.6	8.8
48.0	9.8	10.5	11.2	10.6	8.8
50.0	8.9	9.6	10.3	10.6	8.8
55.0	6.7	7.4	8.1	8.8	
60.0	4.7	5.4	5.9	6.4	
65.0	3.1	3.6	4.0		
危険角度(°)	35	37	39	45	60
フック種類	24t				
フック質量(t)	0.88				
掛数	2				

KATO KA-3000R

■定格総荷重表

●50mブーム+4.4m+31mヘビーリフトジブ

HA性能					
オフセット	10°	20°	30°	45°	60°
作業半径(m)	荷重 (t)	荷重 (t)	荷重 (t)	荷重 (t)	荷重 (t)
16.0	9.0				
18.0	9.0				
20.0	9.0				
22.0	9.0	9.0			
24.0	9.0	9.0			
26.0	9.0	9.0	8.4		
28.0	9.0	9.0	8.2		
30.0	9.0	9.0	8.0		
32.0	9.0	9.0	7.8	6.3	
34.0	9.0	8.8	7.7	6.2	
36.0	9.0	8.6	7.5	6.1	4.7
38.0	9.0	8.4	7.4	6.0	4.7
40.0	9.0	8.3	7.3	6.0	4.7
42.0	9.0	8.1	7.2	5.9	4.7
44.0	8.9	8.0	7.2	5.9	4.7
46.0	8.8	7.9	7.1	5.9	4.7
48.0	8.1	7.9	7.1	5.9	4.7
50.0	7.4	7.8	7.0	5.9	4.7
55.0	5.9	6.4	6.9	5.9	4.7
60.0	4.4	5.1	5.4	5.9	
65.0	2.8	3.4	3.8	4.2	
危険角度(°)	38	40	42	45	60
フック種類	24t				
フック質量(t)	0.88				
掛数	2				

●53.9mブーム+4.4m+31mヘビーリフトジブ

HA性能					
オフセット	10°	20°	30°	45°	60°
作業半径(m)	荷重 (t)	荷重 (t)	荷重 (t)	荷重 (t)	荷重 (t)
18.0	8.0				
20.0	8.0				
22.0	8.0	7.5			
24.0	8.0	7.2			
26.0	8.0	7.0	6.0		
28.0	8.0	6.8	5.8		
30.0	7.8	6.7	5.7		
32.0	7.6	6.5	5.6	4.3	
34.0	7.4	6.4	5.5	4.2	
36.0	7.2	6.2	5.4	4.2	3.1
38.0	7.0	6.1	5.3	4.1	3.1
40.0	6.9	6.0	5.2	4.1	3.1
42.0	6.7	5.9	5.1	4.1	3.1
44.0	6.6	5.8	5.1	4.1	3.1
46.0	6.5	5.8	5.1	4.1	3.1
48.0	6.4	5.7	5.0	4.1	3.1
50.0	6.1	5.7	5.0	4.1	3.1
55.0	4.7	5.2	5.0	4.1	3.1
60.0	3.4	3.9	4.3	4.1	
65.0		2.8	3.1	3.5	
危険角度(°)	46	46	47	48	60
フック種類	24t				
フック質量(t)	0.88				
掛数	2				

●14.4mブーム+4.4m+31mヘビーリフトジブ

HB性能					
オフセット	10°	20°	30°	45°	60°
作業半径(m)	荷重 (t)	荷重 (t)	荷重 (t)	荷重 (t)	荷重 (t)
11.0	35.0				
12.0	35.0				
14.0	35.0				
16.0	34.5	34.1			
18.0	34.5	33.8			
20.0	34.5	31.6			
22.0	33.1	29.2	26.1		
24.0	30.4	27.1	24.5		
26.0	28.2	25.4	23.1	19.7	
28.0	26.2	23.8	21.8	18.8	
30.0	24.5	22.4	20.7	18.0	13.1
32.0	23.0	21.2	19.7	17.3	12.8
34.0	21.6	20.2	18.9	16.7	12.5
36.0	20.5	19.2	18.1	16.2	12.3
38.0	19.4	18.3	17.4	15.8	12.2
40.0	18.5	17.6	16.8	15.5	
42.0	17.3	16.9	16.4	15.4	
44.0	16.0	16.3	16.0		
46.0	14.8	15.0			
危険角度(°)	10	20	30	45	60
フック種類	83t				
フック質量(t)	1.00				
掛数	4				

●19.55mブーム+4.4m+31mヘビーリフトジブ

HB性能					
オフセット	10°	20°	30°	45°	60°
作業半径(m)	荷重 (t)	荷重 (t)	荷重 (t)	荷重 (t)	荷重 (t)
12.0	34.0				
14.0	34.0				
16.0	34.0				
18.0	34.0	34.0			
20.0	34.0	33.0			
22.0	34.0	30.6	26.8		
24.0	32.9	28.6	25.2		
26.0	30.5	26.8	23.9		
28.0	28.5	25.2	22.7	19.8	
30.0	26.6	23.9	21.6	19.0	
32.0	24.1	22.6	20.6	18.4	14.0
34.0	21.9	21.5	19.8	17.8	13.7
36.0	19.9	20.5	19.0	17.3	13.5
38.0	18.2	19.1	18.3	16.8	13.3
40.0	16.6	17.4	17.7	16.4	13.3
42.0	15.2	15.9	16.6	16.1	
44.0	13.9	14.5	15.1	15.7	
46.0	12.8	13.3	13.7	14.0	
48.0	11.7	12.1	12.4		
50.0	10.7	11.0			
危険角度(°)	10	20	30	45	60
フック種類	83t				
フック質量(t)	1.00				
掛数	4				

●23.6mブーム+4.4m+31mヘビーリフトジブ

HB性能					
オフセット	10°	20°	30°	45°	60°
作業半径(m)	荷重 (t)	荷重 (t)	荷重 (t)	荷重 (t)	荷重 (t)
12.0	30.0				
14.0	30.0				
16.0	30.0				
18.0	30.0	30.0			
20.0	30.0	30.0			
22.0	30.0	30.0	27.2		
24.0	30.0	29.6	25.8		
26.0	30.0	27.8	24.4		
28.0	28.1	26.3	23.3	20.0	
30.0	25.2	24.9	22.2	19.3	
32.0	22.7	23.6	21.3	18.6	14.8
34.0	20.5	21.9	20.4	18.1	14.5
36.0	18.6	19.8	19.6	17.6	14.2
38.0	16.8	17.9	18.9	17.1	14.0
40.0	15.3	16.3	17.2	16.7	13.9
42.0	13.8	14.7	15.6	16.4	13.9
44.0	12.6	13.4	14.1	14.9	
46.0	11.4	12.1	12.7	13.4	
48.0	10.3	10.9	11.4	11.9	
50.0	9.3	9.8	10.2		
55.0	7.2	7.3			
危険角度(°)	10	20	30	45	60
フック種類	83t				
フック質量(t)	1.00				
掛数	4				

●32mブーム+4.4m+31mヘビーリフトジブ

HB性能					
オフセット	10°	20°	30°	45°	60°
作業半径(m)	荷重 (t)	荷重 (t)	荷重 (t)	荷重 (t)	荷重 (t)
14.0	20.0				
16.0	20.0				
18.0	20.0				
20.0	20.0	20.0			
22.0	20.0	20.0			
24.0	20.0	20.0	19.6		
26.0	20.0	20.0	19.1		
28.0	20.0	20.0	18.6		
30.0	20.0	20.0	18.2	15.3	
32.0	20.0	19.6	17.8	15.0	
34.0	20.0	19.2	17.4	14.8	12.2
36.0	18.1	18.7	17.1	14.6	12.1
38.0	16.3	17.6	16.8	14.4	12.0
40.0	14.7	15.9	16.6	14.3	12.0
42.0	13.3	14.4	15.4	14.2	12.0
44.0	12.0	13.0	13.9	14.1	12.0
46.0	10.8	11.7	12.5	13.5	12.0
48.0	9.7	10.5	11.2	12.1	
50.0	8.7	9.4	10.1	10.8	
55.0	6.5	7.0	7.5		
60.0	4.7	5.0	5.1		
危険角度(°)	15	20	30	45	60
フック種類	24t				
フック質量(t)	0.88				
掛数	2				

KA-3000R

KATO KA-3000R

■ 定格総荷重表

● 40mブーム+4.4m+31mヘビーフットジブ

HB性能					
オフセット	10°	20°	30°	45°	60°
作業半径(m)	荷重 (t)	荷重 (t)	荷重 (t)	荷重 (t)	荷重 (t)
16.0	14.0				
18.0	14.0				
20.0	14.0	14.0			
22.0	14.0	14.0			
24.0	14.0	14.0	14.0		
26.0	14.0	14.0	14.0		
28.0	14.0	14.0	14.0		
30.0	14.0	14.0	14.0	13.4	
32.0	14.0	14.0	14.0	13.2	
34.0	14.0	14.0	14.0	13.0	10.5
36.0	14.0	14.0	14.0	12.8	10.5
38.0	14.0	14.0	14.0	12.7	10.4
40.0	14.0	14.0	14.0	12.5	10.4
42.0	12.7	13.9	14.0	12.4	10.3
44.0	11.4	12.5	13.5	12.4	10.3
46.0	10.2	11.2	12.2	12.3	10.3
48.0	9.1	10.0	10.9	12.0	10.3
50.0	8.1	9.0	9.8	10.7	10.3
55.0	5.9	6.6	7.2	7.8	
60.0	4.1	4.6	5.0	5.3	
65.0		2.9	3.1		
危険角度(°)	33	33	35	45	60
フック種類	24t				
フック質量(t)	0.88				
掛数	2				

● 45mブーム+4.4m+31mヘビーフットジブ

HB性能					
オフセット	10°	20°	30°	45°	60°
作業半径(m)	荷重 (t)	荷重 (t)	荷重 (t)	荷重 (t)	荷重 (t)
16.0	12.0				
18.0	12.0				
20.0	12.0	12.0			
22.0	12.0	12.0			
24.0	12.0	12.0			
26.0	12.0	12.0	12.0		
28.0	12.0	12.0	12.0		
30.0	12.0	12.0	12.0	11.5	
32.0	12.0	12.0	12.0	11.3	
34.0	12.0	12.0	12.0	11.2	9.0
36.0	12.0	12.0	12.0	11.0	8.9
38.0	12.0	12.0	12.0	10.9	8.9
40.0	12.0	12.0	12.0	10.8	8.8
42.0	12.0	12.0	12.0	10.7	8.8
44.0	11.0	12.0	12.0	10.6	8.8
46.0	9.8	10.9	11.9	10.6	8.8
48.0	8.7	9.8	10.7	10.6	8.8
50.0	7.7	8.7	9.6	10.6	8.8
55.0	5.5	6.3	7.0	7.8	
60.0	3.7	4.4	4.9	5.4	
65.0		2.7	3.0		
危険角度(°)	39	40	42	45	60
フック種類	24t				
フック質量(t)	0.88				
掛数	2				

● 50mブーム+4.4m+31mヘビーフットジブ

HB性能					
オフセット	10°	20°	30°	45°	60°
作業半径(m)	荷重 (t)	荷重 (t)	荷重 (t)	荷重 (t)	荷重 (t)
16.0	9.0				
18.0	9.0				
20.0	9.0				
22.0	9.0	9.0			
24.0	9.0	9.0			
26.0	9.0	9.0	8.4		
28.0	9.0	9.0	8.2		
30.0	9.0	9.0	8.0		
32.0	9.0	9.0	7.8	6.3	
34.0	9.0	8.8	7.7	6.2	
36.0	9.0	8.6	7.5	6.1	4.7
38.0	9.0	8.4	7.4	6.0	4.7
40.0	9.0	8.3	7.3	6.0	4.7
42.0	9.0	8.1	7.2	5.9	4.7
44.0	8.9	8.0	7.2	5.9	4.7
46.0	8.8	7.9	7.1	5.9	4.7
48.0	8.1	7.9	7.1	5.9	4.7
50.0	7.4	7.8	7.0	5.9	4.7
55.0	5.2	6.1	6.8	5.9	4.7
60.0	3.4	4.1	4.7	5.3	
65.0			2.9	3.3	
危険角度(°)	44	46	46	47	60
フック種類	24t				
フック質量(t)	0.88				
掛数	2				

● 53.9mブーム+4.4m+31mヘビーフットジブ

HB性能					
オフセット	10°	20°	30°	45°	60°
作業半径(m)	荷重 (t)	荷重 (t)	荷重 (t)	荷重 (t)	荷重 (t)
18.0	8.0				
20.0	8.0				
22.0	8.0	7.5			
24.0	8.0	7.2			
26.0	8.0	7.0	6.0		
28.0	8.0	6.8	5.8		
30.0	7.8	6.7	5.7		
32.0	7.6	6.5	5.6	4.3	
34.0	7.4	6.4	5.5	4.2	
36.0	7.2	6.2	5.4	4.2	3.1
38.0	7.0	6.1	5.3	4.1	3.1
40.0	6.9	6.0	5.2	4.1	3.1
42.0	6.7	5.9	5.1	4.1	3.1
44.0	6.6	5.8	5.1	4.1	3.1
46.0	6.5	5.8	5.1	4.1	3.1
48.0	6.4	5.7	5.0	4.1	3.1
50.0	6.1	5.7	5.0	4.1	3.1
55.0	4.7	5.2	5.0	4.1	3.1
60.0	3.2	3.9	4.3	4.1	
65.0			2.8	3.3	
危険角度(°)	48	49	49	50	60
フック種類	24t				
フック質量(t)	0.88				
掛数	2				

● 14.4mブーム+4.4m+31mヘビーフットジブ

HC性能					
オフセット	10°	20°	30°	45°	60°
作業半径(m)	荷重 (t)	荷重 (t)	荷重 (t)	荷重 (t)	荷重 (t)
11.0	35.0				
12.0	35.0				
14.0	35.0				
16.0	34.5	34.1			
18.0	34.5	33.8			
20.0	34.5	31.6			
22.0	33.1	29.2	26.1		
24.0	30.4	27.1	24.5		
26.0	28.2	25.4	23.1	19.7	
28.0	26.2	23.8	21.8	18.8	
30.0	24.5	22.4	20.7	18.0	13.1
32.0	23.0	21.2	19.7	17.3	12.8
34.0	21.6	20.2	18.9	16.7	12.5
36.0	20.2	19.2	18.1	16.2	12.3
38.0	18.6	18.3	17.4	15.8	12.2
40.0	17.1	17.6	16.8	15.5	
42.0	15.8	16.2	16.4	15.4	
44.0	14.6	14.9	15.2		
46.0	13.5	13.7			
危険角度(°)	10	20	30	45	60
フック種類	83t				
フック質量(t)	1.00				
掛数	4				

● 19.55mブーム+4.4m+31mヘビーフットジブ

HC性能					
オフセット	10°	20°	30°	45°	60°
作業半径(m)	荷重 (t)	荷重 (t)	荷重 (t)	荷重 (t)	荷重 (t)
12.0	34.0				
14.0	34.0				
16.0	34.0				
18.0	34.0	34.0			
20.0	34.0	33.0			
22.0	34.0	30.6	26.8		
24.0	32.9	28.6	25.2		
26.0	30.3	26.8	23.9		
28.0	27.2	25.2	22.7	19.8	
30.0	24.5	23.9	21.6	19.0	
32.0	22.2	22.6	20.6	18.4	14.0
34.0	20.1	21.2	19.8	17.8	13.7
36.0	18.2	19.2	19.0	17.3	13.5
38.0	16.6	17.5	18.3	16.8	13.3
40.0	15.1	15.9	16.7	16.4	13.3
42.0	13.8	14.5	15.1	15.9	
44.0	12.5	13.1	13.7	14.3	
46.0	11.4	11.9	12.4	12.7	
48.0	10.4	10.8	11.1		
50.0	9.5	9.7			
危険角度(°)	10	20	30	45	60
フック種類	83t				
フック質量(t)	1.00				
掛数	4				

KATO KA-3000R

■ 定格総荷重表

● 23.6mブーム+4.4m+31mヘビーリフトジブ

HC性能					
オフセット	10°	20°	30°	45°	60°
作業半径(m)	荷重 (t)	荷重 (t)	荷重 (t)	荷重 (t)	荷重 (t)
12.0	30.0				
14.0	30.0				
16.0	30.0				
18.0	30.0	30.0			
20.0	30.0	30.0			
22.0	30.0	30.0	27.2		
24.0	30.0	29.6	25.8		
26.0	29.1	27.8	24.4		
28.0	25.9	26.3	23.3	20.0	
30.0	23.2	24.8	22.2	19.3	
32.0	20.8	22.3	21.3	18.6	14.8
34.0	18.7	20.1	20.4	18.1	14.5
36.0	16.9	18.1	19.3	17.6	14.2
38.0	15.2	16.3	17.4	17.1	14.0
40.0	13.7	14.7	15.7	16.7	13.9
42.0	12.4	13.3	14.1	15.2	13.9
44.0	11.2	12.0	12.7	13.6	
46.0	10.1	10.8	11.4	12.1	
48.0	9.0	9.6	10.2	10.6	
50.0	8.1	8.6	9.0		
55.0	6.1	6.2			
危険角度(°)	10	20	30	45	60
フック種類	83t				
フック質量(t)	1.00				
掛数	4				

● 32mブーム+4.4m+31mヘビーリフトジブ

HC性能					
オフセット	10°	20°	30°	45°	60°
作業半径(m)	荷重 (t)	荷重 (t)	荷重 (t)	荷重 (t)	荷重 (t)
14.0	20.0				
16.0	20.0				
18.0	20.0				
20.0	20.0	20.0			
22.0	20.0	20.0			
24.0	20.0	20.0	19.6		
26.0	20.0	20.0	19.1		
28.0	20.0	20.0	18.6		
30.0	20.0	20.0	18.2	15.3	
32.0	20.0	19.6	17.8	15.0	
34.0	18.2	19.2	17.4	14.8	12.2
36.0	16.4	17.8	17.1	14.6	12.1
38.0	14.7	16.0	16.8	14.4	12.0
40.0	13.2	14.4	15.5	14.3	12.0
42.0	11.8	12.9	13.9	14.2	12.0
44.0	10.6	11.6	12.5	13.6	12.0
46.0	9.5	10.4	11.2	12.2	12.0
48.0	8.4	9.3	10.0	10.8	
50.0	7.5	8.2	8.9	9.5	
55.0	5.4	5.9	6.4		
60.0	3.7	4.0	4.1		
危険角度(°)	15	20	30	45	60
フック種類	24t				
フック質量(t)	0.88				
掛数	2				

● 40mブーム+4.4m+31mヘビーリフトジブ

HC性能					
オフセット	10°	20°	30°	45°	60°
作業半径(m)	荷重 (t)	荷重 (t)	荷重 (t)	荷重 (t)	荷重 (t)
16.0	14.0				
18.0	14.0				
20.0	14.0	14.0			
22.0	14.0	14.0			
24.0	14.0	14.0	14.0		
26.0	14.0	14.0	14.0		
28.0	14.0	14.0	14.0		
30.0	14.0	14.0	14.0	13.4	
32.0	14.0	14.0	14.0	13.2	
34.0	14.0	14.0	14.0	13.0	10.5
36.0	14.0	14.0	14.0	12.8	10.5
38.0	14.0	14.0	14.0	12.7	10.4
40.0	12.6	13.9	14.0	12.5	10.4
42.0	11.2	12.4	13.5	12.4	10.3
44.0	10.0	11.1	12.1	12.4	10.3
46.0	8.8	9.9	10.8	12.0	10.3
48.0	7.8	8.8	9.6	10.7	10.3
50.0	6.9	7.7	8.5	9.5	9.9
55.0	4.8	5.5	6.1	6.7	
60.0	3.1	3.6	4.0	4.3	
危険角度(°)	36	39	41	45	60
フック種類	24t				
フック質量(t)	0.88				
掛数	2				

● 45mブーム+4.4m+31mヘビーリフトジブ

HC性能					
オフセット	10°	20°	30°	45°	60°
作業半径(m)	荷重 (t)	荷重 (t)	荷重 (t)	荷重 (t)	荷重 (t)
16.0	12.0				
18.0	12.0				
20.0	12.0	12.0			
22.0	12.0	12.0			
24.0	12.0	12.0			
26.0	12.0	12.0	12.0		
28.0	12.0	12.0	12.0		
30.0	12.0	12.0	12.0	11.5	
32.0	12.0	12.0	12.0	11.3	
34.0	12.0	12.0	12.0	11.2	9.0
36.0	12.0	12.0	12.0	11.0	8.9
38.0	12.0	12.0	12.0	10.9	8.9
40.0	12.0	12.0	12.0	10.8	8.8
42.0	10.9	12.0	12.0	10.7	8.8
44.0	9.6	10.8	11.9	10.6	8.8
46.0	8.5	9.6	10.6	10.6	8.8
48.0	7.5	8.5	9.4	10.6	8.8
50.0	6.5	7.5	8.3	9.4	8.8
55.0	4.4	5.2	5.9	6.7	
60.0	2.7	3.3	3.9	4.4	
危険角度(°)	41	43	45	45	60
フック種類	24t				
フック質量(t)	0.88				
掛数	2				

● 50mブーム+4.4m+31mヘビーリフトジブ

HC性能					
オフセット	10°	20°	30°	45°	60°
作業半径(m)	荷重 (t)	荷重 (t)	荷重 (t)	荷重 (t)	荷重 (t)
16.0	9.0				
18.0	9.0				
20.0	9.0				
22.0	9.0	9.0			
24.0	9.0	9.0			
26.0	9.0	9.0	8.4		
28.0	9.0	9.0	8.2		
30.0	9.0	9.0	8.0		
32.0	9.0	9.0	7.8	6.3	
34.0	9.0	8.8	7.7	6.2	
36.0	9.0	8.6	7.5	6.1	4.7
38.0	9.0	8.4	7.4	6.0	4.7
40.0	9.0	8.3	7.3	6.0	4.7
42.0	9.0	8.1	7.2	5.9	4.7
44.0	8.9	8.0	7.2	5.9	4.7
46.0	8.2	7.9	7.1	5.9	4.7
48.0	7.1	7.9	7.1	5.9	4.7
50.0	6.2	7.2	7.0	5.9	4.7
55.0	4.1	5.0	5.7	5.9	4.7
60.0		3.1	3.7	4.3	
危険角度(°)	49	49	50	51	60
フック種類	24t				
フック質量(t)	0.88				
掛数	2				

● 53.9mブーム+4.4m+31mヘビーリフトジブ

HC性能					
オフセット	10°	20°	30°	45°	60°
作業半径(m)	荷重 (t)	荷重 (t)	荷重 (t)	荷重 (t)	荷重 (t)
18.0	8.0				
20.0	8.0				
22.0	8.0	7.5			
24.0	8.0	7.2			
26.0	8.0	7.0	6.0		
28.0	8.0	6.8	5.8		
30.0	7.8	6.7	5.7		
32.0	7.6	6.5	5.6	4.3	
34.0	7.4	6.4	5.5	4.2	
36.0	7.2	6.2	5.4	4.2	3.1
38.0	7.0	6.1	5.3	4.1	3.1
40.0	6.9	6.0	5.2	4.1	3.1
42.0	6.7	5.9	5.1	4.1	3.1
44.0	6.6	5.8	5.1	4.1	3.1
46.0	6.5	5.8	5.1	4.1	3.1
48.0	6.4	5.7	5.0	4.1	3.1
50.0	6.0	5.7	5.0	4.1	3.1
55.0	3.9	4.8	5.0	4.1	3.1
60.0		2.9	3.6	4.1	
危険角度(°)	51	51	52	53	60
フック種類	24t				
フック質量(t)	0.88				
掛数	2				

KA-3000R

KATO KA-3000R

■ 定格総荷重表

● 14.4mブーム+4.4m+40mヘビーリフトジブ

HA性能					
オフセット	10°	20°	30°	45°	60°
作業半径(m)	荷重 (t)	荷重 (t)	荷重 (t)	荷重 (t)	荷重 (t)
14.0	12.0				
16.0	12.0				
18.0	12.0				
20.0	12.0	12.0			
22.0	12.0	12.0			
24.0	12.0	12.0			
26.0	12.0	12.0	12.0		
28.0	12.0	12.0	12.0		
30.0	12.0	12.0	12.0		
32.0	12.0	12.0	12.0		
34.0	12.0	12.0	12.0	12.0	
36.0	12.0	12.0	12.0	11.9	
38.0	12.0	12.0	12.0	11.3	
40.0	12.0	12.0	12.0	10.8	9.5
42.0	12.0	12.0	11.5	10.3	9.3
44.0	12.0	11.7	10.9	9.9	9.1
46.0	11.8	11.1	10.4	9.6	9.0
48.0	11.2	10.5	10.0	9.3	
50.0	10.6	10.1	9.6	9.1	
55.0	9.4	9.1			
危険角度(°)	10	20	30	45	60
フック種類	12t				
フック質量(t)	0.53				
掛数	1				

● 19.55mブーム+4.4m+40mヘビーリフトジブ

HA性能					
オフセット	10°	20°	30°	45°	60°
作業半径(m)	荷重 (t)	荷重 (t)	荷重 (t)	荷重 (t)	荷重 (t)
16.0	12.0				
18.0	12.0				
20.0	12.0				
22.0	12.0	12.0			
24.0	12.0	12.0			
26.0	12.0	12.0			
28.0	12.0	12.0	12.0		
30.0	12.0	12.0	12.0		
32.0	12.0	12.0	12.0		
34.0	12.0	12.0	12.0	12.0	
36.0	12.0	12.0	12.0	12.0	
38.0	12.0	12.0	12.0	11.6	
40.0	12.0	12.0	12.0	11.1	10.0
42.0	12.0	12.0	12.0	10.7	9.7
44.0	12.0	12.0	11.6	10.3	9.4
46.0	12.0	12.0	11.1	10.0	9.2
48.0	12.0	11.4	10.6	9.7	9.1
50.0	11.8	10.9	10.2	9.4	9.0
55.0	10.4	9.8	9.4	9.1	
60.0	9.2	9.1			
危険角度(°)	10	20	30	45	60
フック種類	12t				
フック質量(t)	0.53				
掛数	1				

● 23.6mブーム+4.4m+40mヘビーリフトジブ

HA性能					
オフセット	10°	20°	30°	45°	60°
作業半径(m)	荷重 (t)	荷重 (t)	荷重 (t)	荷重 (t)	荷重 (t)
16.0	12.0				
18.0	12.0				
20.0	12.0				
22.0	12.0	12.0			
24.0	12.0	12.0			
26.0	12.0	12.0			
28.0	12.0	12.0	12.0		
30.0	12.0	12.0	12.0		
32.0	12.0	12.0	12.0		
34.0	12.0	12.0	12.0		
36.0	12.0	12.0	12.0	12.0	
38.0	12.0	12.0	12.0	11.8	
40.0	12.0	12.0	12.0	11.4	10.1
42.0	12.0	12.0	12.0	10.9	9.8
44.0	12.0	12.0	12.0	10.6	9.5
46.0	12.0	12.0	11.6	10.2	9.3
48.0	12.0	12.0	11.1	9.9	9.2
50.0	12.0	11.6	10.7	9.6	9.1
55.0	10.0	10.4	9.8	9.2	
60.0	8.1	8.5	8.8		
65.0	5.5				
危険角度(°)	10	20	30	45	60
フック種類	12t				
フック質量(t)	0.53				
掛数	1				

● 32mブーム+4.4m+40mヘビーリフトジブ

HA性能					
オフセット	10°	20°	30°	45°	60°
作業半径(m)	荷重 (t)	荷重 (t)	荷重 (t)	荷重 (t)	荷重 (t)
18.0	12.0				
20.0	12.0				
22.0	12.0				
24.0	12.0	12.0			
26.0	12.0	12.0			
28.0	12.0	12.0			
30.0	12.0	12.0	12.0		
32.0	12.0	12.0	12.0		
34.0	12.0	12.0	12.0		
36.0	12.0	12.0	12.0	12.0	
38.0	12.0	12.0	12.0	12.0	
40.0	12.0	12.0	12.0	11.8	
42.0	12.0	12.0	12.0	11.4	9.5
44.0	12.0	12.0	12.0	11.0	9.4
46.0	12.0	12.0	12.0	10.7	9.3
48.0	12.0	12.0	12.0	10.4	9.3
50.0	11.5	12.0	11.5	10.1	9.2
55.0	9.2	10.0	10.6	9.5	9.0
60.0	7.2	7.9	8.5	9.1	
65.0	5.6	6.1	6.5		
70.0	4.1	4.4			
危険角度(°)	12	20	30	45	60
フック種類	12t				
フック質量(t)	0.53				
掛数	1				

● 40mブーム+4.4m+40mヘビーリフトジブ

HA性能					
オフセット	10°	20°	30°	45°	60°
作業半径(m)	荷重 (t)	荷重 (t)	荷重 (t)	荷重 (t)	荷重 (t)
18.0	11.0				
20.0	11.0				
22.0	11.0				
24.0	11.0	11.0			
26.0	11.0	11.0			
28.0	11.0	11.0			
30.0	11.0	11.0	11.0		
32.0	11.0	11.0	11.0		
34.0	11.0	11.0	11.0		
36.0	11.0	11.0	11.0		
38.0	11.0	11.0	11.0	10.5	
40.0	11.0	11.0	11.0	10.3	
42.0	11.0	11.0	11.0	10.1	8.1
44.0	11.0	11.0	11.0	10.0	8.0
46.0	11.0	11.0	11.0	9.9	8.0
48.0	11.0	11.0	11.0	9.8	7.9
50.0	10.9	11.0	11.0	9.7	7.9
55.0	8.5	9.5	10.5	9.5	7.9
60.0	6.6	7.4	8.2	9.1	7.9
65.0	4.9	5.6	6.2	6.8	
70.0	3.5	4.0	4.4		
75.0	2.2	2.6	2.8		
危険角度(°)	20	22	30	45	60
フック種類	12t				
フック質量(t)	0.53				
掛数	1				

● 45mブーム+4.4m+40mヘビーリフトジブ

HA性能					
オフセット	10°	20°	30°	45°	60°
作業半径(m)	荷重 (t)	荷重 (t)	荷重 (t)	荷重 (t)	荷重 (t)
18.0	10.0				
20.0	10.0				
22.0	10.0				
24.0	10.0				
26.0	10.0	10.0			
28.0	10.0	10.0			
30.0	10.0	10.0	10.0		
32.0	10.0	10.0	10.0		
34.0	10.0	10.0	10.0		
36.0	10.0	10.0	10.0		
38.0	10.0	10.0	10.0	8.9	
40.0	10.0	10.0	10.0	8.8	
42.0	10.0	10.0	10.0	8.7	
44.0	10.0	10.0	10.0	8.5	6.8
46.0	10.0	10.0	10.0	8.4	6.7
48.0	10.0	10.0	10.0	8.3	6.7
50.0	9.8	10.0	9.9	8.3	6.7
55.0	8.0	8.8	9.5	8.1	6.7
60.0	6.2	7.1	7.7	8.1	6.7
65.0	4.5	5.3	6.0	6.7	
70.0	3.1	3.7	4.3	4.7	
75.0	1.9	2.4	2.7		
危険角度(°)	30	32	34	45	60
フック種類	12t				
フック質量(t)	0.53				
掛数	1				

KATO KA-3000R

■ 定格総荷重表

● 50mブーム+4.4m+40mヘビーリフトジブ

HA性能					
オフセット	10°	20°	30°	45°	60°
作業半径(m)	荷重 (t)	荷重 (t)	荷重 (t)	荷重 (t)	荷重 (t)
20.0	7.0				
22.0	7.0				
24.0	7.0				
26.0	7.0	7.0			
28.0	7.0	7.0			
30.0	7.0	7.0			
32.0	7.0	7.0	6.5		
34.0	7.0	7.0	6.3		
36.0	7.0	7.0	6.2		
38.0	7.0	7.0	6.1		
40.0	7.0	6.8	5.9	4.7	
42.0	7.0	6.7	5.8	4.6	
44.0	7.0	6.5	5.7	4.5	3.4
46.0	7.0	6.4	5.6	4.5	3.4
48.0	7.0	6.3	5.5	4.4	3.3
50.0	6.9	6.2	5.5	4.4	3.3
55.0	6.6	6.0	5.3	4.3	3.3
60.0	5.3	5.8	5.2	4.3	3.3
65.0	4.2	4.7	5.1	4.3	3.3
70.0	2.8	3.5	4.0	4.3	
75.0	1.6	2.1	2.6	3.0	
危険角度(°)	36	39	41	45	60
フック種類	12t				
フック質量(t)	0.53				
掛数	1				

● 53.9mブーム+4.4m+40mヘビーリフトジブ

HA性能					
オフセット	10°	20°	30°	45°	60°
作業半径(m)	荷重 (t)	荷重 (t)	荷重 (t)	荷重 (t)	荷重 (t)
20.0	6.0				
22.0	6.0				
24.0	6.0				
26.0	6.0	6.0			
28.0	6.0	5.8			
30.0	6.0	5.6			
32.0	6.0	5.4	4.5		
34.0	6.0	5.2	4.4		
36.0	6.0	5.1	4.3		
38.0	5.8	5.0	4.2		
40.0	5.6	4.8	4.1	3.1	
42.0	5.5	4.7	4.0	3.0	
44.0	5.4	4.6	3.9	3.0	2.1
46.0	5.2	4.5	3.9	2.9	2.1
48.0	5.1	4.5	3.8	2.9	2.1
50.0	5.0	4.4	3.8	2.9	2.1
55.0	4.8	4.2	3.7	2.9	2.1
60.0	4.1	4.1	3.6	2.9	2.1
65.0	3.1	3.6	3.6	2.9	2.1
70.0	2.1	2.6	3.0	2.9	
75.0		1.7	2.1	2.4	
危険角度(°)	44	44	45	46	60
フック種類	12t				
フック質量(t)	0.53				
掛数	1				

● 14.4mブーム+4.4m+40mヘビーリフトジブ

HB性能					
オフセット	10°	20°	30°	45°	60°
作業半径(m)	荷重 (t)	荷重 (t)	荷重 (t)	荷重 (t)	荷重 (t)
14.0	12.0				
16.0	12.0				
18.0	12.0				
20.0	12.0	12.0			
22.0	12.0	12.0			
24.0	12.0	12.0			
26.0	12.0	12.0	12.0		
28.0	12.0	12.0	12.0		
30.0	12.0	12.0	12.0		
32.0	12.0	12.0	12.0		
34.0	12.0	12.0	12.0	12.0	
36.0	12.0	12.0	12.0	11.9	
38.0	12.0	12.0	12.0	11.3	
40.0	12.0	12.0	12.0	10.8	9.5
42.0	12.0	12.0	11.5	10.3	9.3
44.0	12.0	11.7	10.9	9.9	9.1
46.0	11.8	11.1	10.4	9.6	9.0
48.0	11.2	10.5	10.0	9.3	
50.0	10.6	10.1	9.6	9.1	
55.0	9.4	9.1			
危険角度(°)	10	20	30	45	60
フック種類	12t				
フック質量(t)	0.53				
掛数	1				

● 19.55mブーム+4.4m+40mヘビーリフトジブ

HB性能					
オフセット	10°	20°	30°	45°	60°
作業半径(m)	荷重 (t)	荷重 (t)	荷重 (t)	荷重 (t)	荷重 (t)
16.0	12.0				
18.0	12.0				
20.0	12.0				
22.0	12.0	12.0			
24.0	12.0	12.0			
26.0	12.0	12.0			
28.0	12.0	12.0	12.0		
30.0	12.0	12.0	12.0		
32.0	12.0	12.0	12.0		
34.0	12.0	12.0	12.0	12.0	
36.0	12.0	12.0	12.0	12.0	
38.0	12.0	12.0	12.0	11.6	
40.0	12.0	12.0	12.0	11.1	10.0
42.0	12.0	12.0	12.0	10.7	9.7
44.0	12.0	12.0	11.6	10.3	9.4
46.0	12.0	12.0	11.1	10.0	9.2
48.0	12.0	11.4	10.6	9.7	9.1
50.0	11.8	10.9	10.2	9.4	9.0
55.0	10.1	9.8	9.4	9.1	
60.0	8.2	8.4			
危険角度(°)	10	20	30	45	60
フック種類	12t				
フック質量(t)	0.53				
掛数	1				

● 23.6mブーム+4.4m+40mヘビーリフトジブ

HB性能					
オフセット	10°	20°	30°	45°	60°
作業半径(m)	荷重 (t)	荷重 (t)	荷重 (t)	荷重 (t)	荷重 (t)
16.0	12.0				
18.0	12.0				
20.0	12.0				
22.0	12.0	12.0			
24.0	12.0	12.0			
26.0	12.0	12.0			
28.0	12.0	12.0	12.0		
30.0	12.0	12.0	12.0		
32.0	12.0	12.0	12.0		
34.0	12.0	12.0	12.0		
36.0	12.0	12.0	12.0	12.0	
38.0	12.0	12.0	12.0	11.8	
40.0	12.0	12.0	12.0	11.4	10.1
42.0	12.0	12.0	12.0	10.9	9.8
44.0	12.0	12.0	12.0	10.6	9.5
46.0	12.0	12.0	11.6	10.2	9.3
48.0	12.0	12.0	11.1	9.9	9.2
50.0	11.2	11.6	10.7	9.6	9.1
55.0	8.9	9.6	9.8	9.2	
60.0	7.0	7.5	7.8		
65.0	5.4				
危険角度(°)	10	20	30	45	60
フック種類	12t				
フック質量(t)	0.53				
掛数	1				

● 32mブーム+4.4m+40mヘビーリフトジブ

HB性能					
オフセット	10°	20°	30°	45°	60°
作業半径(m)	荷重 (t)	荷重 (t)	荷重 (t)	荷重 (t)	荷重 (t)
18.0	12.0				
20.0	12.0				
22.0	12.0				
24.0	12.0	12.0			
26.0	12.0	12.0			
28.0	12.0	12.0			
30.0	12.0	12.0	12.0		
32.0	12.0	12.0	12.0		
34.0	12.0	12.0	12.0		
36.0	12.0	12.0	12.0	12.0	
38.0	12.0	12.0	12.0	12.0	
40.0	12.0	12.0	12.0	11.8	
42.0	12.0	12.0	12.0	11.4	9.5
44.0	12.0	12.0	12.0	11.0	9.4
46.0	12.0	12.0	12.0	10.7	9.3
48.0	11.3	12.0	12.0	10.4	9.3
50.0	10.3	11.4	11.5	10.1	9.2
55.0	8.1	8.9	9.7	9.5	9.0
60.0	6.2	6.9	7.5	8.1	
65.0	4.6	5.1	5.5		
70.0	3.2	3.5			
危険角度(°)	12	20	30	45	60
フック種類	12t				
フック質量(t)	0.53				
掛数	1				

KA-3000R

KATO KA-3000R

■ 定格総荷重表

● 40mブーム+4.4m+40mヘビーリフトジブ

HB性能					
オフセット	10°	20°	30°	45°	60°
作業半径(m)	荷重 (t)	荷重 (t)	荷重 (t)	荷重 (t)	荷重 (t)
18.0	11.0				
20.0	11.0				
22.0	11.0				
24.0	11.0				
26.0	11.0	11.0			
28.0	11.0	11.0			
30.0	11.0	11.0	11.0		
32.0	11.0	11.0	11.0		
34.0	11.0	11.0	11.0		
36.0	11.0	11.0	11.0		
38.0	11.0	11.0	11.0	10.5	
40.0	11.0	11.0	11.0	10.3	
42.0	11.0	11.0	11.0	10.1	8.1
44.0	11.0	11.0	11.0	10.0	8.0
46.0	11.0	11.0	11.0	9.9	8.0
48.0	10.7	11.0	11.0	9.8	7.9
50.0	9.6	10.8	11.0	9.7	7.9
55.0	7.4	8.4	9.4	9.5	7.9
60.0	5.6	6.4	7.2	8.1	7.9
65.0	4.0	4.7	5.2	5.9	
70.0	2.6	3.1	3.5		
75.0		1.8	2.0		
危険角度(°)	31	31	33	45	60
フック種類	12t				
フック質量(t)	0.53				
掛数	1				

● 45mブーム+4.4m+40mヘビーリフトジブ

HB性能					
オフセット	10°	20°	30°	45°	60°
作業半径(m)	荷重 (t)	荷重 (t)	荷重 (t)	荷重 (t)	荷重 (t)
18.0	10.0				
20.0	10.0				
22.0	10.0				
24.0	10.0				
26.0	10.0	10.0			
28.0	10.0	10.0			
30.0	10.0	10.0	10.0		
32.0	10.0	10.0	10.0		
34.0	10.0	10.0	10.0		
36.0	10.0	10.0	10.0		
38.0	10.0	10.0	10.0	8.9	
40.0	10.0	10.0	10.0	8.8	
42.0	10.0	10.0	10.0	8.7	
44.0	10.0	10.0	10.0	8.5	6.8
46.0	10.0	10.0	10.0	8.4	6.7
48.0	10.0	10.0	10.0	8.3	6.7
50.0	9.3	10.0	9.9	8.3	6.7
55.0	7.0	8.1	9.1	8.1	6.7
60.0	5.2	6.1	6.9	8.0	6.7
65.0	3.6	4.4	5.1	5.8	
70.0	2.3	2.9	3.4	3.9	
75.0			1.9		
危険角度(°)	37	40	40	45	60
フック種類	12t				
フック質量(t)	0.53				
掛数	1				

● 50mブーム+4.4m+40mヘビーリフトジブ

HB性能					
オフセット	10°	20°	30°	45°	60°
作業半径(m)	荷重 (t)	荷重 (t)	荷重 (t)	荷重 (t)	荷重 (t)
20.0	7.0				
22.0	7.0				
24.0	7.0				
26.0	7.0	7.0			
28.0	7.0	7.0			
30.0	7.0	7.0			
32.0	7.0	7.0	6.5		
34.0	7.0	7.0	6.3		
36.0	7.0	7.0	6.2		
38.0	7.0	7.0	6.1		
40.0	7.0	6.8	5.9	4.7	
42.0	7.0	6.7	5.8	4.6	
44.0	7.0	6.5	5.7	4.5	3.4
46.0	7.0	6.4	5.6	4.5	3.4
48.0	7.0	6.3	5.5	4.4	3.3
50.0	6.9	6.2	5.5	4.4	3.3
55.0	6.6	6.0	5.3	4.3	3.3
60.0	4.8	5.8	5.2	4.3	3.3
65.0	3.3	4.1	4.9	4.3	3.3
70.0	1.9	2.6	3.2	3.9	
75.0			1.8	2.1	
危険角度(°)	42	45	45	46	60
フック種類	12t				
フック質量(t)	0.53				
掛数	1				

● 53.9mブーム+4.4m+40mヘビーリフトジブ

HB性能					
オフセット	10°	20°	30°	45°	60°
作業半径(m)	荷重 (t)	荷重 (t)	荷重 (t)	荷重 (t)	荷重 (t)
20.0	6.0				
22.0	6.0				
24.0	6.0				
26.0	6.0	6.0			
28.0	6.0	5.8			
30.0	6.0	5.6			
32.0	6.0	5.4	4.5		
34.0	6.0	5.2	4.4		
36.0	6.0	5.1	4.3		
38.0	5.8	5.0	4.2		
40.0	5.6	4.8	4.1	3.1	
42.0	5.5	4.7	4.0	3.0	
44.0	5.4	4.6	3.9	3.0	2.1
46.0	5.2	4.5	3.9	2.9	2.1
48.0	5.1	4.5	3.8	2.9	2.1
50.0	5.0	4.4	3.8	2.9	2.1
55.0	4.8	4.2	3.7	2.9	2.1
60.0	4.1	4.1	3.6	2.9	2.1
65.0	3.0	3.6	3.6	2.9	2.1
70.0	1.7	2.4	3.0	2.9	
75.0			1.7	2.1	
危険角度(°)	46	47	47	48	60
フック種類	12t				
フック質量(t)	0.53				
掛数	1				

● 14.4mブーム+4.4m+40mヘビーリフトジブ

HC性能					
オフセット	10°	20°	30°	45°	60°
作業半径(m)	荷重 (t)	荷重 (t)	荷重 (t)	荷重 (t)	荷重 (t)
14.0	12.0				
16.0	12.0				
18.0	12.0				
20.0	12.0	12.0			
22.0	12.0	12.0			
24.0	12.0	12.0			
26.0	12.0	12.0	12.0		
28.0	12.0	12.0	12.0		
30.0	12.0	12.0	12.0		
32.0	12.0	12.0	12.0		
34.0	12.0	12.0	12.0	12.0	
36.0	12.0	12.0	12.0	11.9	
38.0	12.0	12.0	12.0	11.3	
40.0	12.0	12.0	12.0	10.8	9.5
42.0	12.0	12.0	11.5	10.3	9.3
44.0	12.0	11.7	10.9	9.9	9.1
46.0	11.8	11.1	10.4	9.6	9.0
48.0	11.2	10.5	10.0	9.3	
50.0	10.6	10.1	9.6	9.1	
55.0	9.4	9.1			
危険角度(°)	10	20	30	45	60
フック種類	12t				
フック質量(t)	0.53				
掛数	1				

● 19.55mブーム+4.4m+40mヘビーリフトジブ

HC性能					
オフセット	10°	20°	30°	45°	60°
作業半径(m)	荷重 (t)	荷重 (t)	荷重 (t)	荷重 (t)	荷重 (t)
16.0	12.0				
18.0	12.0				
20.0	12.0				
22.0	12.0	12.0			
24.0	12.0	12.0			
26.0	12.0	12.0			
28.0	12.0	12.0	12.0		
30.0	12.0	12.0	12.0		
32.0	12.0	12.0	12.0		
34.0	12.0	12.0	12.0	12.0	
36.0	12.0	12.0	12.0	12.0	
38.0	12.0	12.0	12.0	11.6	
40.0	12.0	12.0	12.0	11.1	10.0
42.0	12.0	12.0	12.0	10.7	9.7
44.0	12.0	12.0	11.6	10.3	9.4
46.0	12.0	12.0	11.1	10.0	9.2
48.0	12.0	11.4	10.6	9.7	9.1
50.0	11.1	10.9	10.2	9.4	9.0
55.0	9.0	9.5	9.4	9.1	
60.0	7.2	7.4			
危険角度(°)	10	20	30	45	60
フック種類	12t				
フック質量(t)	0.53				
掛数	1				

KATO KA-3000R

■ 定格総荷重表

● 23.6mブーム+4.4m+40mヘビーリフトジブ

HC性能					
オフセット	10°	20°	30°	45°	60°
作業半径(m)	荷重 (t)	荷重 (t)	荷重 (t)	荷重 (t)	荷重 (t)
16.0	12.0				
18.0	12.0				
20.0	12.0				
22.0	12.0				
24.0	12.0	12.0			
26.0	12.0	12.0			
28.0	12.0	12.0	12.0		
30.0	12.0	12.0	12.0		
32.0	12.0	12.0	12.0		
34.0	12.0	12.0	12.0		
36.0	12.0	12.0	12.0	12.0	
38.0	12.0	12.0	12.0	11.8	
40.0	12.0	12.0	12.0	11.4	10.1
42.0	12.0	12.0	12.0	10.9	9.8
44.0	12.0	12.0	12.0	10.6	9.5
46.0	12.0	12.0	11.6	10.2	9.3
48.0	10.9	11.9	11.1	9.9	9.2
50.0	9.9	10.8	10.7	9.6	9.1
55.0	7.8	8.5	9.1	9.2	
60.0	6.0	6.5	6.8		
65.0	4.4				
危険角度(°)	10	20	30	45	60
フック種類	12t				
フック質量(t)	0.53				
掛数	1				

● 32mブーム+4.4m+40mヘビーリフトジブ

HC性能					
オフセット	10°	20°	30°	45°	60°
作業半径(m)	荷重 (t)	荷重 (t)	荷重 (t)	荷重 (t)	荷重 (t)
18.0	12.0				
20.0	12.0				
22.0	12.0				
24.0	12.0	12.0			
26.0	12.0	12.0			
28.0	12.0	12.0			
30.0	12.0	12.0	12.0		
32.0	12.0	12.0	12.0		
34.0	12.0	12.0	12.0		
36.0	12.0	12.0	12.0	12.0	
38.0	12.0	12.0	12.0	12.0	
40.0	12.0	12.0	12.0	11.8	
42.0	12.0	12.0	12.0	11.4	9.5
44.0	12.0	12.0	12.0	11.0	9.4
46.0	11.1	12.0	12.0	10.7	9.3
48.0	10.1	11.2	12.0	10.4	9.3
50.0	9.1	10.1	11.1	10.1	9.2
55.0	7.0	7.8	8.6	9.5	9.0
60.0	5.2	5.9	6.5	7.1	
65.0	3.7	4.2	4.6		
70.0	2.4	2.6			
危険角度(°)	12	20	30	45	60
フック種類	12t				
フック質量(t)	0.53				
掛数	1				

● 40mブーム+4.4m+40mヘビーリフトジブ

HC性能					
オフセット	10°	20°	30°	45°	60°
作業半径(m)	荷重 (t)	荷重 (t)	荷重 (t)	荷重 (t)	荷重 (t)
18.0	11.0				
20.0	11.0				
22.0	11.0				
24.0	11.0	11.0			
26.0	11.0	11.0			
28.0	11.0	11.0			
30.0	11.0	11.0	11.0		
32.0	11.0	11.0	11.0		
34.0	11.0	11.0	11.0		
36.0	11.0	11.0	11.0		
38.0	11.0	11.0	11.0	10.5	
40.0	11.0	11.0	11.0	10.3	
42.0	11.0	11.0	11.0	10.1	8.1
44.0	11.0	11.0	11.0	10.0	8.0
46.0	10.4	11.0	11.0	9.9	8.0
48.0	9.4	10.7	11.0	9.8	7.9
50.0	8.4	9.6	10.7	9.7	7.9
55.0	6.3	7.3	8.3	9.4	7.9
60.0	4.5	5.4	6.1	7.0	7.4
65.0	3.0	3.7	4.3	4.9	
70.0	1.7	2.3	2.7		
危険角度(°)	34	35	36	45	60
フック種類	12t				
フック質量(t)	0.53				
掛数	1				

● 45mブーム+4.4m+40mヘビーリフトジブ

HC性能					
オフセット	10°	20°	30°	45°	60°
作業半径(m)	荷重 (t)	荷重 (t)	荷重 (t)	荷重 (t)	荷重 (t)
18.0	10.0				
20.0	10.0				
22.0	10.0				
24.0	10.0				
26.0	10.0	10.0			
28.0	10.0	10.0			
30.0	10.0	10.0	10.0		
32.0	10.0	10.0	10.0		
34.0	10.0	10.0	10.0		
36.0	10.0	10.0	10.0		
38.0	10.0	10.0	10.0	8.9	
40.0	10.0	10.0	10.0	8.8	
42.0	10.0	10.0	10.0	8.7	
44.0	10.0	10.0	10.0	8.5	6.8
46.0	10.0	10.0	10.0	8.4	6.7
48.0	9.0	10.0	10.0	8.3	6.7
50.0	8.0	9.3	9.9	8.3	6.7
55.0	5.9	7.0	8.0	8.1	6.7
60.0	4.2	5.1	5.9	6.9	6.7
65.0	2.7	3.4	4.1	4.9	
70.0		2.0	2.5	3.0	
危険角度(°)	43	43	44	45	60
フック種類	12t				
フック質量(t)	0.53				
掛数	1				

● 50mブーム+4.4m+40mヘビーリフトジブ

HC性能					
オフセット	10°	20°	30°	45°	60°
作業半径(m)	荷重 (t)	荷重 (t)	荷重 (t)	荷重 (t)	荷重 (t)
20.0	7.0				
22.0	7.0				
24.0	7.0				
26.0	7.0	7.0			
28.0	7.0	7.0			
30.0	7.0	7.0			
32.0	7.0	7.0	6.5		
34.0	7.0	7.0	6.3		
36.0	7.0	7.0	6.2		
38.0	7.0	7.0	6.1		
40.0	7.0	6.8	5.9	4.7	
42.0	7.0	6.7	5.8	4.6	
44.0	7.0	6.5	5.7	4.5	3.4
46.0	7.0	6.4	5.6	4.5	3.4
48.0	7.0	6.3	5.5	4.4	3.3
50.0	6.9	6.2	5.5	4.4	3.3
55.0	5.6	6.0	5.3	4.3	3.3
60.0	3.8	4.8	5.2	4.3	3.3
65.0	2.3	3.2	3.9	4.3	3.3
70.0		1.8	2.4	3.0	
危険角度(°)	46	47	48	49	60
フック種類	12t				
フック質量(t)	0.53				
掛数	1				

● 53.9mブーム+4.4m+40mヘビーリフトジブ

HC性能					
オフセット	10°	20°	30°	45°	60°
作業半径(m)	荷重 (t)	荷重 (t)	荷重 (t)	荷重 (t)	荷重 (t)
20.0	6.0				
22.0	6.0				
24.0	6.0				
26.0	6.0	6.0			
28.0	6.0	5.8			
30.0	6.0	5.6			
32.0	6.0	5.4	4.5		
34.0	6.0	5.2	4.4		
36.0	6.0	5.1	4.3		
38.0	5.8	5.0	4.2		
40.0	5.6	4.8	4.1	3.1	
42.0	5.5	4.7	4.0	3.0	
44.0	5.4	4.6	3.9	3.0	2.1
46.0	5.2	4.5	3.9	2.9	2.1
48.0	5.1	4.5	3.8	2.9	2.1
50.0	5.0	4.4	3.8	2.9	2.1
55.0	4.8	4.2	3.7	2.9	2.1
60.0	3.6	4.1	3.6	2.9	2.1
65.0	2.1	3.0	3.6	2.9	2.1
70.0		1.6	2.2	2.9	
危険角度(°)	50	50	51	52	60
フック種類	12t				
フック質量(t)	0.53				
掛数	1				

KA-3000R

KATO KA-3000R

■ 定格総荷重表

● 14.4mブーム+4.4m+47mヘビーリフトジブ

HA性能					
オフセット	10°	20°	30°	45°	60°
作業半径(m)	荷重 (t)	荷重 (t)	荷重 (t)	荷重 (t)	荷重 (t)
16.0	12.0				
18.0	12.0				
20.0	12.0				
22.0	12.0				
24.0	12.0	12.0			
26.0	12.0	12.0			
28.0	12.0	12.0			
30.0	12.0	12.0			
32.0	12.0	12.0	12.0		
34.0	12.0	12.0	12.0		
36.0	12.0	12.0	11.8		
38.0	12.0	12.0	11.1		
40.0	12.0	11.4	10.4	9.1	
42.0	11.8	10.7	9.8	8.7	
44.0	11.0	10.1	9.3	8.3	
46.0	10.3	9.5	8.8	7.9	7.2
48.0	9.7	9.0	8.4	7.6	7.0
50.0	9.1	8.5	8.0	7.3	6.8
55.0	8.0	7.6	7.2	6.7	
60.0	7.0	6.8	6.6		
危険角度(°)	10	20	30	45	60
フック種類	12t				
フック質量(t)	0.53				
掛数	1				

● 19.55mブーム+4.4m+47mヘビーリフトジブ

HA性能					
オフセット	10°	20°	30°	45°	60°
作業半径(m)	荷重 (t)	荷重 (t)	荷重 (t)	荷重 (t)	荷重 (t)
18.0	12.0				
20.0	12.0				
22.0	12.0				
24.0	12.0	12.0			
26.0	12.0	12.0			
28.0	12.0	12.0			
30.0	12.0	12.0			
32.0	12.0	12.0	12.0		
34.0	12.0	12.0	12.0		
36.0	12.0	12.0	12.0		
38.0	12.0	12.0	11.5		
40.0	12.0	12.0	10.9	9.3	
42.0	12.0	11.5	10.3	8.9	
44.0	12.0	10.8	9.8	8.5	
46.0	11.4	10.2	9.3	8.1	7.3
48.0	10.7	9.7	8.9	7.8	7.1
50.0	10.1	9.2	8.5	7.5	6.9
55.0	8.8	8.2	7.6	7.0	6.6
60.0	7.8	7.3	7.0	6.6	
65.0	7.0	6.7	6.6		
危険角度(°)	10	20	30	45	60
フック種類	12t				
フック質量(t)	0.53				
掛数	1				

● 23.6mブーム+4.4m+47mヘビーリフトジブ

HA性能					
オフセット	10°	20°	30°	45°	60°
作業半径(m)	荷重 (t)	荷重 (t)	荷重 (t)	荷重 (t)	荷重 (t)
18.0	12.0				
20.0	12.0				
22.0	12.0				
24.0	12.0				
26.0	12.0	12.0			
28.0	12.0	12.0			
30.0	12.0	12.0			
32.0	12.0	12.0	12.0		
34.0	12.0	12.0	12.0		
36.0	12.0	12.0	12.0		
38.0	12.0	12.0	11.8		
40.0	12.0	12.0	11.2	9.4	
42.0	12.0	12.0	10.6	9.0	
44.0	12.0	11.4	10.1	8.6	
46.0	12.0	10.8	9.6	8.3	7.3
48.0	11.5	10.2	9.2	8.0	7.1
50.0	10.8	9.7	8.8	7.7	7.0
55.0	9.5	8.6	8.0	7.1	6.6
60.0	8.4	7.8	7.3	6.7	
65.0	7.0	7.1	6.8	6.5	
70.0	5.5	5.8			
危険角度(°)	10	20	30	45	60
フック種類	12t				
フック質量(t)	0.53				
掛数	1				

● 32mブーム+4.4m+47mヘビーリフトジブ

HA性能					
オフセット	10°	20°	30°	45°	60°
作業半径(m)	荷重 (t)	荷重 (t)	荷重 (t)	荷重 (t)	荷重 (t)
20.0	12.0				
22.0	12.0				
24.0	12.0				
26.0	12.0	12.0			
28.0	12.0	12.0			
30.0	12.0	12.0			
32.0	12.0	12.0			
34.0	12.0	12.0	12.0		
36.0	12.0	12.0	12.0		
38.0	12.0	12.0	12.0		
40.0	12.0	12.0	11.8		
42.0	12.0	12.0	11.3	9.2	
44.0	12.0	12.0	10.8	8.9	
46.0	12.0	11.8	10.3	8.6	
48.0	12.0	11.3	9.8	8.3	7.2
50.0	12.0	10.7	9.4	8.0	7.1
55.0	9.8	9.6	8.6	7.5	6.7
60.0	7.8	8.6	7.9	7.0	6.5
65.0	6.1	6.9	7.3	6.7	
70.0	4.7	5.3	5.8	6.2	
75.0	3.4	3.8	4.1		
80.0	1.8				
危険角度(°)	15	20	30	45	60
フック種類	12t				
フック質量(t)	0.53				
掛数	1				

● 40mブーム+4.4m+47mヘビーリフトジブ

HA性能					
オフセット	10°	20°	30°	45°	60°
作業半径(m)	荷重 (t)	荷重 (t)	荷重 (t)	荷重 (t)	荷重 (t)
20.0	8.0				
22.0	8.0				
24.0	8.0				
26.0	8.0				
28.0	8.0	8.0			
30.0	8.0	8.0			
32.0	8.0	8.0			
34.0	8.0	8.0	8.0		
36.0	8.0	8.0	8.0		
38.0	8.0	8.0	8.0		
40.0	8.0	8.0	8.0		
42.0	8.0	8.0	8.0		
44.0	8.0	8.0	8.0	8.0	
46.0	8.0	8.0	8.0	8.0	
48.0	8.0	8.0	8.0	8.0	
50.0	8.0	8.0	8.0	8.0	6.3
55.0	8.0	8.0	8.0	7.7	6.2
60.0	7.1	8.0	8.0	7.3	6.1
65.0	5.4	6.3	7.1	6.9	6.1
70.0	4.0	4.7	5.4	6.1	
75.0	2.8	3.3	3.8	4.3	
80.0	1.7	2.1	2.4		
危険角度(°)	25	28	30	45	60
フック種類	12t				
フック質量(t)	0.53				
掛数	1				

● 45mブーム+4.4m+47mヘビーリフトジブ

HA性能					
オフセット	10°	20°	30°	45°	60°
作業半径(m)	荷重 (t)	荷重 (t)	荷重 (t)	荷重 (t)	荷重 (t)
20.0	7.5				
22.0	7.5				
24.0	7.5				
26.0	7.5				
28.0	7.5	7.5			
30.0	7.5	7.5			
32.0	7.5	7.5			
34.0	7.5	7.5			
36.0	7.5	7.5	7.5		
38.0	7.5	7.5	7.5		
40.0	7.5	7.5	7.5		
42.0	7.5	7.5	7.5		
44.0	7.5	7.5	7.5	7.1	
46.0	7.5	7.5	7.5	7.0	
48.0	7.5	7.5	7.5	6.8	
50.0	7.5	7.5	7.5	6.7	5.2
55.0	7.5	7.5	7.5	6.5	5.1
60.0	6.7	7.5	7.5	6.4	5.1
65.0	5.1	6.0	6.7	6.3	5.1
70.0	3.6	4.4	5.2	6.0	5.1
75.0	2.4	3.1	3.6	4.3	
80.0		1.8	2.3	2.6	
危険角度(°)	38	38	40	45	60
フック種類	12t				
フック質量(t)	0.53				
掛数	1				

KATO KA-3000R

■ 定格総荷重表

● 50mブーム+4.4m+47mヘビーリフトジブ

HA性能					
オフセット	10°	20°	30°	45°	60°
作業半径(m)	荷重 (t)	荷重 (t)	荷重 (t)	荷重 (t)	荷重 (t)
22.0	5.0				
24.0	5.0				
26.0	5.0				
28.0	5.0				
30.0	5.0	5.0			
32.0	5.0	5.0			
34.0	5.0	5.0			
36.0	5.0	5.0	5.0		
38.0	5.0	5.0	4.9		
40.0	5.0	5.0	4.8		
42.0	5.0	5.0	4.6		
44.0	5.0	5.0	4.5	3.4	
46.0	5.0	5.0	4.4	3.3	
48.0	5.0	5.0	4.3	3.3	
50.0	5.0	4.9	4.2	3.2	2.2
55.0	5.0	4.7	4.1	3.1	2.2
60.0	5.0	4.5	3.9	3.1	2.2
65.0	4.2	4.4	3.9	3.0	2.2
70.0	3.3	3.8	3.8	3.0	2.2
75.0	2.0	2.8	3.3	3.0	
80.0		1.6	2.1	2.6	
危険角度(°)	42	43	44	45	60
フック種類	12t				
フック質量(t)	0.53				
掛数	1				

● 53.9mブーム+4.4m+47mヘビーリフトジブ

HA性能					
オフセット	10°	20°	30°	45°	60°
作業半径(m)	荷重 (t)	荷重 (t)	荷重 (t)	荷重 (t)	荷重 (t)
22.0	4.0				
24.0	4.0				
26.0	4.0				
28.0	4.0				
30.0	4.0	4.0			
32.0	4.0	4.0			
34.0	4.0	4.0			
36.0	4.0	4.0	3.3		
38.0	4.0	3.9	3.2		
40.0	4.0	3.8	3.1		
42.0	4.0	3.6	3.0		
44.0	4.0	3.5	2.9		
46.0	4.0	3.4	2.8	2.0	
48.0	4.0	3.4	2.8	1.9	
50.0	3.9	3.3	2.7	1.9	
55.0	3.6	3.1	2.6	1.8	
60.0	3.4	3.0	2.5	1.8	
65.0	3.0	2.9	2.4	1.8	
70.0	2.2	2.8	2.4	1.8	
75.0		1.9	2.4	1.8	
80.0				1.8	
危険角度(°)	49	49	51	51	
フック種類	12t				
フック質量(t)	0.53				
掛数	1				

● 14.4mブーム+4.4m+47mヘビーリフトジブ

HB性能					
オフセット	10°	20°	30°	45°	60°
作業半径(m)	荷重 (t)	荷重 (t)	荷重 (t)	荷重 (t)	荷重 (t)
16.0	12.0				
18.0	12.0				
20.0	12.0				
22.0	12.0				
24.0	12.0	12.0			
26.0	12.0	12.0			
28.0	12.0	12.0			
30.0	12.0	12.0			
32.0	12.0	12.0	12.0		
34.0	12.0	12.0	12.0		
36.0	12.0	12.0	11.8		
38.0	12.0	12.0	11.1		
40.0	12.0	11.4	10.4	9.1	
42.0	11.8	10.7	9.8	8.7	
44.0	11.0	10.1	9.3	8.3	
46.0	10.3	9.5	8.8	7.9	7.2
48.0	9.7	9.0	8.4	7.6	7.0
50.0	9.1	8.5	8.0	7.3	6.8
55.0	8.0	7.6	7.2	6.7	
60.0	7.0	6.8	6.6		
危険角度(°)	10	20	30	45	60
フック種類	12t				
フック質量(t)	0.53				
掛数	1				

● 19.55mブーム+4.4m+47mヘビーリフトジブ

HB性能					
オフセット	10°	20°	30°	45°	60°
作業半径(m)	荷重 (t)	荷重 (t)	荷重 (t)	荷重 (t)	荷重 (t)
18.0	12.0				
20.0	12.0				
22.0	12.0				
24.0	12.0	12.0			
26.0	12.0	12.0			
28.0	12.0	12.0			
30.0	12.0	12.0			
32.0	12.0	12.0	12.0		
34.0	12.0	12.0	12.0		
36.0	12.0	12.0	12.0		
38.0	12.0	12.0	11.5		
40.0	12.0	12.0	10.9	9.3	
42.0	12.0	11.5	10.3	8.9	
44.0	12.0	10.8	9.8	8.5	
46.0	11.4	10.2	9.3	8.1	7.3
48.0	10.7	9.7	8.9	7.8	7.1
50.0	10.1	9.2	8.5	7.5	6.9
55.0	8.8	8.2	7.6	7.0	6.6
60.0	7.8	7.3	7.0	6.6	
65.0	7.0	6.7	6.6		
危険角度(°)	10	20	30	45	60
フック種類	12t				
フック質量(t)	0.53				
掛数	1				

● 23.6mブーム+4.4m+47mヘビーリフトジブ

HB性能					
オフセット	10°	20°	30°	45°	60°
作業半径(m)	荷重 (t)	荷重 (t)	荷重 (t)	荷重 (t)	荷重 (t)
18.0	12.0				
20.0	12.0				
22.0	12.0				
24.0	12.0				
26.0	12.0	12.0			
28.0	12.0	12.0			
30.0	12.0	12.0			
32.0	12.0	12.0	12.0		
34.0	12.0	12.0	12.0		
36.0	12.0	12.0	12.0		
38.0	12.0	12.0	11.8		
40.0	12.0	12.0	11.2	9.4	
42.0	12.0	12.0	10.6	9.0	
44.0	12.0	11.4	10.1	8.6	
46.0	12.0	10.8	9.6	8.3	7.3
48.0	11.5	10.2	9.2	8.0	7.1
50.0	10.8	9.7	8.8	7.7	7.0
55.0	9.5	8.6	8.0	7.1	6.6
60.0	7.7	7.8	7.3	6.7	
65.0	6.1	6.6	6.8	6.5	
70.0	4.7	4.9			
危険角度(°)	10	20	30	45	60
フック種類	12t				
フック質量(t)	0.53				
掛数	1				

● 32mブーム+4.4m+47mヘビーリフトジブ

HB性能					
オフセット	10°	20°	30°	45°	60°
作業半径(m)	荷重 (t)	荷重 (t)	荷重 (t)	荷重 (t)	荷重 (t)
20.0	12.0				
22.0	12.0				
24.0	12.0				
26.0	12.0	12.0			
28.0	12.0	12.0			
30.0	12.0	12.0			
32.0	12.0	12.0			
34.0	12.0	12.0	12.0		
36.0	12.0	12.0	12.0		
38.0	12.0	12.0	12.0		
40.0	12.0	12.0	11.8		
42.0	12.0	12.0	11.3	9.2	
44.0	12.0	12.0	10.8	8.9	
46.0	12.0	11.8	10.3	8.6	
48.0	11.9	11.3	9.8	8.3	7.2
50.0	10.9	10.7	9.4	8.0	7.1
55.0	8.7	9.6	8.6	7.5	6.7
60.0	6.8	7.7	7.9	7.0	6.5
65.0	5.2	5.9	6.6	6.7	
70.0	3.8	4.4	4.9	5.3	
75.0	2.6	3.0	3.3		
危険角度(°)	18	20	30	45	60
フック種類	12t				
フック質量(t)	0.53				
掛数	1				

KA-3000R

KATO KA-3000R

■ 定格総荷重表

● 40mブーム+4.4m+47mヘビーリフトジブ

HB性能					
オフセット	10°	20°	30°	45°	60°
作業半径(m)	荷重 (t)	荷重 (t)	荷重 (t)	荷重 (t)	荷重 (t)
20.0	8.0				
22.0	8.0				
24.0	8.0				
26.0	8.0				
28.0	8.0	8.0			
30.0	8.0	8.0			
32.0	8.0	8.0			
34.0	8.0	8.0	8.0		
36.0	8.0	8.0	8.0		
38.0	8.0	8.0	8.0		
40.0	8.0	8.0	8.0		
42.0	8.0	8.0	8.0		
44.0	8.0	8.0	8.0	8.0	
46.0	8.0	8.0	8.0	8.0	
48.0	8.0	8.0	8.0	8.0	
50.0	8.0	8.0	8.0	8.0	6.3
55.0	8.0	8.0	8.0	7.7	6.2
60.0	6.1	7.1	8.0	7.3	6.1
65.0	4.5	5.4	6.2	6.9	6.1
70.0	3.1	3.9	4.5	5.3	
75.0	2.0	2.5	3.0	3.5	
80.0			1.6		
危険角度(°)	33	37	37	45	60
フック種類	12t				
フック質量(t)	0.53				
掛数	1				

● 45mブーム+4.4m+47mヘビーリフトジブ

HB性能					
オフセット	10°	20°	30°	45°	60°
作業半径(m)	荷重 (t)	荷重 (t)	荷重 (t)	荷重 (t)	荷重 (t)
20.0	7.5				
22.0	7.5				
24.0	7.5				
26.0	7.5				
28.0	7.5	7.5			
30.0	7.5	7.5			
32.0	7.5	7.5			
34.0	7.5	7.5			
36.0	7.5	7.5	7.5		
38.0	7.5	7.5	7.5		
40.0	7.5	7.5	7.5		
42.0	7.5	7.5	7.5		
44.0	7.5	7.5	7.5	7.1	
46.0	7.5	7.5	7.5	7.0	
48.0	7.5	7.5	7.5	6.8	
50.0	7.5	7.5	7.5	6.7	5.2
55.0	7.5	7.5	7.5	6.5	5.1
60.0	5.7	6.8	7.5	6.4	5.1
65.0	4.1	5.1	6.0	6.3	5.1
70.0	2.8	3.6	4.3	5.2	5.1
75.0	1.6	2.2	2.8	3.5	
80.0				1.8	
危険角度(°)	40	42	44	45	60
フック種類	12t				
フック質量(t)	0.53				
掛数	1				

● 50mブーム+4.4m+47mヘビーリフトジブ

HB性能					
オフセット	10°	20°	30°	45°	60°
作業半径(m)	荷重 (t)	荷重 (t)	荷重 (t)	荷重 (t)	荷重 (t)
22.0	5.0				
24.0	5.0				
26.0	5.0				
28.0	5.0				
30.0	5.0	5.0			
32.0	5.0	5.0			
34.0	5.0	5.0			
36.0	5.0	5.0	5.0		
38.0	5.0	5.0	4.9		
40.0	5.0	5.0	4.8		
42.0	5.0	5.0	4.6		
44.0	5.0	5.0	4.5	3.4	
46.0	5.0	5.0	4.4	3.3	
48.0	5.0	5.0	4.3	3.3	
50.0	5.0	4.9	4.2	3.2	2.2
55.0	5.0	4.7	4.1	3.1	2.2
60.0	5.0	4.5	3.9	3.1	2.2
65.0	3.8	4.4	3.9	3.0	2.2
70.0	2.4	3.3	3.8	3.0	2.2
75.0		2.0	2.6	3.0	
80.0				1.8	
危険角度(°)	47	47	49	49	60
フック種類	12t				
フック質量(t)	0.53				
掛数	1				

● 53.9mブーム+4.4m+47mヘビーリフトジブ

HB性能					
オフセット	10°	20°	30°	45°	60°
作業半径(m)	荷重 (t)	荷重 (t)	荷重 (t)	荷重 (t)	荷重 (t)
22.0	4.0				
24.0	4.0				
26.0	4.0				
28.0	4.0				
30.0	4.0	4.0			
32.0	4.0	4.0			
34.0	4.0	4.0			
36.0	4.0	4.0	3.3		
38.0	4.0	3.9	3.2		
40.0	4.0	3.8	3.1		
42.0	4.0	3.6	3.0		
44.0	4.0	3.5	2.9		
46.0	4.0	3.4	2.8	2.0	
48.0	4.0	3.4	2.8	1.9	
50.0	3.9	3.3	2.7	1.9	
55.0	3.6	3.1	2.6	1.8	
60.0	3.4	3.0	2.5	1.8	
65.0	3.0	2.9	2.4	1.8	
70.0	2.1	2.8	2.4	1.8	
75.0		1.8	2.4	1.8	
80.0				1.8	
危険角度(°)	50	50	52	52	
フック種類	12t				
フック質量(t)	0.53				
掛数	1				

● 14.4mブーム+4.4m+47mヘビーリフトジブ

HC性能					
オフセット	10°	20°	30°	45°	60°
作業半径(m)	荷重 (t)	荷重 (t)	荷重 (t)	荷重 (t)	荷重 (t)
16.0	12.0				
18.0	12.0				
20.0	12.0				
22.0	12.0				
24.0	12.0	12.0			
26.0	12.0	12.0			
28.0	12.0	12.0			
30.0	12.0	12.0			
32.0	12.0	12.0	12.0		
34.0	12.0	12.0	12.0		
36.0	12.0	12.0	11.8		
38.0	12.0	12.0	11.1		
40.0	12.0	11.4	10.4	9.1	
42.0	11.8	10.7	9.8	8.7	
44.0	11.0	10.1	9.3	8.3	
46.0	10.3	9.5	8.8	7.9	7.2
48.0	9.7	9.0	8.4	7.6	7.0
50.0	9.1	8.5	8.0	7.3	6.8
55.0	8.0	7.6	7.2	6.7	
60.0	7.0	6.8	6.6		
危険角度(°)	10	20	30	45	60
フック種類	12t				
フック質量(t)	0.53				
掛数	1				

● 19.55mブーム+4.4m+47mヘビーリフトジブ

HC性能					
オフセット	10°	20°	30°	45°	60°
作業半径(m)	荷重 (t)	荷重 (t)	荷重 (t)	荷重 (t)	荷重 (t)
18.0	12.0				
20.0	12.0				
22.0	12.0				
24.0	12.0	12.0			
26.0	12.0	12.0			
28.0	12.0	12.0			
30.0	12.0	12.0			
32.0	12.0	12.0	12.0		
34.0	12.0	12.0	12.0		
36.0	12.0	12.0	12.0		
38.0	12.0	12.0	11.5		
40.0	12.0	12.0	10.9	9.3	
42.0	12.0	11.5	10.3	8.9	
44.0	12.0	10.8	9.8	8.5	
46.0	11.4	10.2	9.3	8.1	7.3
48.0	10.7	9.7	8.9	7.8	7.1
50.0	10.1	9.2	8.5	7.5	6.9
55.0	8.8	8.2	7.6	7.0	6.6
60.0	7.8	7.3	7.0	6.6	
65.0	6.3	6.6	6.6		
危険角度(°)	10	20	30	45	60
フック種類	12t				
フック質量(t)	0.53				
掛数	1				

KATO KA-3000R

■ 定格総荷重表

● 23.6mブーム+4.4m+47mヘビーリフトジブ

HC性能					
オフセット	10°	20°	30°	45°	60°
作業半径(m)	荷重 (t)	荷重 (t)	荷重 (t)	荷重 (t)	荷重 (t)
18.0	12.0				
20.0	12.0				
22.0	12.0				
24.0	12.0				
26.0	12.0	12.0			
28.0	12.0	12.0			
30.0	12.0	12.0			
32.0	12.0	12.0	12.0		
34.0	12.0	12.0	12.0		
36.0	12.0	12.0	12.0		
38.0	12.0	12.0	11.8		
40.0	12.0	12.0	11.2	9.4	
42.0	12.0	12.0	10.6	9.0	
44.0	12.0	11.4	10.1	8.6	
46.0	12.0	10.8	9.6	8.3	7.3
48.0	11.5	10.2	9.2	8.0	7.1
50.0	10.6	9.7	8.8	7.7	7.0
55.0	8.4	8.6	8.0	7.1	6.6
60.0	6.7	7.4	7.3	6.7	
65.0	5.1	5.6	6.1	6.5	
70.0	3.8	4.1			
危険角度(°)	10	20	30	45	60
フック種類	12t				
フック質量(t)	0.53				
掛数	1				

● 32mブーム+4.4m+47mヘビーリフトジブ

HC性能					
オフセット	10°	20°	30°	45°	60°
作業半径(m)	荷重 (t)	荷重 (t)	荷重 (t)	荷重 (t)	荷重 (t)
20.0	12.0				
22.0	12.0				
24.0	12.0				
26.0	12.0	12.0			
28.0	12.0	12.0			
30.0	12.0	12.0			
32.0	12.0	12.0			
34.0	12.0	12.0	12.0		
36.0	12.0	12.0	12.0		
38.0	12.0	12.0	12.0		
40.0	12.0	12.0	11.8		
42.0	12.0	12.0	11.3	9.2	
44.0	12.0	12.0	10.8	8.9	
46.0	11.7	11.8	10.3	8.6	
48.0	10.7	11.3	9.8	8.3	7.2
50.0	9.7	10.7	9.4	8.0	7.1
55.0	7.6	8.6	8.6	7.5	6.7
60.0	5.8	6.7	7.5	7.0	6.5
65.0	4.3	5.0	5.7	6.5	
70.0	3.0	3.5	4.0	4.4	
75.0	1.8	2.2	2.5		
危険角度(°)	20	20	30	45	60
フック種類	12t				
フック質量(t)	0.53				
掛数	1				

● 40mブーム+4.4m+47mヘビーリフトジブ

HC性能					
オフセット	10°	20°	30°	45°	60°
作業半径(m)	荷重 (t)	荷重 (t)	荷重 (t)	荷重 (t)	荷重 (t)
20.0	8.0				
22.0	8.0				
24.0	8.0				
26.0	8.0				
28.0	8.0	8.0			
30.0	8.0	8.0			
32.0	8.0	8.0			
34.0	8.0	8.0	8.0		
36.0	8.0	8.0	8.0		
38.0	8.0	8.0	8.0		
40.0	8.0	8.0	8.0		
42.0	8.0	8.0	8.0		
44.0	8.0	8.0	8.0	8.0	
46.0	8.0	8.0	8.0	8.0	
48.0	8.0	8.0	8.0	8.0	
50.0	8.0	8.0	8.0	8.0	6.3
55.0	6.9	8.0	8.0	7.7	6.2
60.0	5.1	6.1	7.1	7.3	6.1
65.0	3.6	4.5	5.3	6.3	6.1
70.0	2.3	3.0	3.7	4.4	
75.0		1.7	2.2	2.7	
危険角度(°)	39	40	41	45	60
フック種類	12t				
フック質量(t)	0.53				
掛数	1				

● 45mブーム+4.4m+47mヘビーリフトジブ

HC性能					
オフセット	10°	20°	30°	45°	60°
作業半径(m)	荷重 (t)	荷重 (t)	荷重 (t)	荷重 (t)	荷重 (t)
20.0	7.5				
22.0	7.5				
24.0	7.5				
26.0	7.5				
28.0	7.5	7.5			
30.0	7.5	7.5			
32.0	7.5	7.5			
34.0	7.5	7.5			
36.0	7.5	7.5	7.5		
38.0	7.5	7.5	7.5		
40.0	7.5	7.5	7.5		
42.0	7.5	7.5	7.5		
44.0	7.5	7.5	7.5	7.1	
46.0	7.5	7.5	7.5	7.0	
48.0	7.5	7.5	7.5	6.8	
50.0	7.5	7.5	7.5	6.7	5.2
55.0	6.5	7.5	7.5	6.5	5.1
60.0	4.7	5.8	6.9	6.4	5.1
65.0	3.2	4.1	5.0	6.2	5.1
70.0	1.9	2.7	3.4	4.3	4.7
75.0			2.0	2.7	
危険角度(°)	44	48	48	48	60
フック種類	12t				
フック質量(t)	0.53				
掛数	1				

● 50mブーム+4.4m+47mヘビーリフトジブ

HC性能					
オフセット	10°	20°	30°	45°	60°
作業半径(m)	荷重 (t)	荷重 (t)	荷重 (t)	荷重 (t)	荷重 (t)
22.0	5.0				
24.0	5.0				
26.0	5.0				
28.0	5.0				
30.0	5.0	5.0			
32.0	5.0	5.0			
34.0	5.0	5.0			
36.0	5.0	5.0	5.0		
38.0	5.0	5.0	4.9		
40.0	5.0	5.0	4.8		
42.0	5.0	5.0	4.6		
44.0	5.0	5.0	4.5	3.4	
46.0	5.0	5.0	4.4	3.3	
48.0	5.0	5.0	4.3	3.3	
50.0	5.0	4.9	4.2	3.2	2.2
55.0	5.0	4.7	4.1	3.1	2.2
60.0	4.3	4.5	3.9	3.1	2.2
65.0	2.8	3.9	3.9	3.0	2.2
70.0		2.4	3.2	3.0	2.2
75.0			1.8	2.6	
危険角度(°)	51	51	51	52	60
フック種類	12t				
フック質量(t)	0.53				
掛数	1				

● 53.9mブーム+4.4m+47mヘビーリフトジブ

HC性能					
オフセット	10°	20°	30°	45°	60°
作業半径(m)	荷重 (t)	荷重 (t)	荷重 (t)	荷重 (t)	荷重 (t)
22.0	4.0				
24.0	4.0				
26.0	4.0				
28.0	4.0				
30.0	4.0	4.0			
32.0	4.0	4.0			
34.0	4.0	4.0			
36.0	4.0	4.0	3.3		
38.0	4.0	3.9	3.2		
40.0	4.0	3.8	3.1		
42.0	4.0	3.6	3.0		
44.0	4.0	3.5	2.9		
46.0	4.0	3.4	2.8	2.0	
48.0	4.0	3.4	2.8	1.9	
50.0	3.9	3.3	2.7	1.9	
55.0	3.6	3.1	2.6	1.8	
60.0	3.4	3.0	2.5	1.8	
65.0	2.6	2.9	2.4	1.8	
70.0		2.2	2.4	1.8	
75.0			1.7	1.8	
危険角度(°)	53	53	53	55	
フック種類	12t				
フック質量(t)	0.53				
掛数	1				

KA-3000R

KATO KA-3000R

■ 定格総荷重表

● 14.4mブーム+4.4m+54mヘビーリフトジブ

HA性能					
オフセット	10°	20°	30°	45°	60°
作業半径(m)	荷重 (t)	荷重 (t)	荷重 (t)	荷重 (t)	荷重 (t)
18.0	9.3				
20.0	9.3				
22.0	9.2				
24.0	9.2				
26.0	9.2				
28.0	9.2	8.9			
30.0	9.0	8.8			
32.0	8.8	8.7			
34.0	8.8	8.6			
36.0	8.8	8.5	7.9		
38.0	8.7	8.1	7.6		
40.0	8.3	7.8	7.3		
42.0	7.9	7.5	7.0		
44.0	7.6	7.2	6.8		
46.0	7.3	6.9	6.6	6.1	
48.0	7.0	6.7	6.4	5.9	
50.0	6.8	6.5	6.2	5.8	
55.0	6.2	6.0	5.7	5.5	5.0
60.0	5.7	5.6	5.4	5.0	4.7
65.0	5.3	5.1	4.9	4.7	
70.0	4.8				
危険角度(°)	10	20	30	45	60
フック種類	12t				
フック質量(t)	0.53				
掛数	1				

● 19.55mブーム+4.4m+54mヘビーリフトジブ

HA性能					
オフセット	10°	20°	30°	45°	60°
作業半径(m)	荷重 (t)	荷重 (t)	荷重 (t)	荷重 (t)	荷重 (t)
20.0	9.3				
22.0	9.2				
24.0	9.2				
26.0	9.2				
28.0	9.0	8.9			
30.0	9.0	8.9			
32.0	8.9	8.9			
34.0	8.9	8.8			
36.0	8.9	8.7	8.0		
38.0	8.8	8.4	7.7		
40.0	8.7	8.0	7.5		
42.0	8.3	7.7	7.2		
44.0	8.0	7.5	7.0		
46.0	7.7	7.2	6.7	6.2	
48.0	7.4	7.0	6.5	6.0	
50.0	7.2	6.7	6.3	5.8	
55.0	6.6	6.2	5.9	5.5	5.1
60.0	6.1	5.8	5.6	5.2	4.8
65.0	5.7	5.5	5.2	4.8	
70.0	5.2	5.0	4.8		
75.0	4.8				
危険角度(°)	10	20	30	45	60
フック種類	12t				
フック質量(t)	0.53				
掛数	1				

● 23.6mブーム+4.4m+54mヘビーリフトジブ

HA性能					
オフセット	10°	20°	30°	45°	60°
作業半径(m)	荷重 (t)	荷重 (t)	荷重 (t)	荷重 (t)	荷重 (t)
20.0	9.3				
22.0	9.3				
24.0	9.2				
26.0	9.2				
28.0	9.2	9.1			
30.0	9.0	8.9			
32.0	8.9	8.8			
34.0	8.9	8.7			
36.0	8.9	8.6	8.1		
38.0	8.8	8.5	7.8		
40.0	8.7	8.2	7.6		
42.0	8.6	7.9	7.3		
44.0	8.3	7.6	7.1		
46.0	8.0	7.4	6.9	6.2	
48.0	7.7	7.1	6.7	6.0	
50.0	7.4	6.9	6.5	5.9	
55.0	6.8	6.4	6.0	5.6	5.1
60.0	6.3	6.0	5.7	5.3	4.8
65.0	5.9	5.6	5.4	4.9	4.7
70.0	5.5	5.3	5.0	4.7	
75.0	4.8	4.9	4.7		
危険角度(°)	15	20	30	45	60
フック種類	12t				
フック質量(t)	0.53				
掛数	1				

● 32mブーム+4.4m+54mヘビーリフトジブ

HA性能					
オフセット	10°	20°	30°	45°	60°
作業半径(m)	荷重 (t)	荷重 (t)	荷重 (t)	荷重 (t)	荷重 (t)
22.0	9.0				
24.0	9.0				
26.0	9.0				
28.0	9.0				
30.0	9.0	8.8			
32.0	9.0	8.7			
34.0	8.9	8.7			
36.0	8.8	8.6			
38.0	8.8	8.6	8.0		
40.0	8.7	8.6	7.7		
42.0	8.6	8.3	7.5		
44.0	8.6	8.0	7.3		
46.0	8.6	7.7	7.1		
48.0	8.3	7.5	6.9	6.1	
50.0	8.0	7.3	6.7	6.0	
55.0	7.4	6.8	6.3	5.7	5.2
60.0	6.8	6.3	5.9	5.5	4.9
65.0	6.4	6.0	5.6	5.2	4.7
70.0	5.2	5.7	5.4	4.9	4.6
75.0	3.9	4.5	5.0	4.7	
80.0	2.8	3.2	3.6		
85.0	1.8	2.0			
危険角度(°)	18	20	30	45	60
フック種類	12t				
フック質量(t)	0.53				
掛数	1				

● 40mブーム+4.4m+54mヘビーリフトジブ

HA性能					
オフセット	10°	20°	30°	45°	60°
作業半径(m)	荷重 (t)	荷重 (t)	荷重 (t)	荷重 (t)	荷重 (t)
22.0	6.0				
24.0	6.0				
26.0	6.0				
28.0	6.0				
30.0	6.0				
32.0	6.0	6.0			
34.0	6.0	6.0			
36.0	6.0	6.0			
38.0	6.0	6.0	6.0		
40.0	6.0	6.0	6.0		
42.0	6.0	6.0	6.0		
44.0	6.0	6.0	6.0		
46.0	6.0	6.0	6.0		
48.0	6.0	6.0	6.0	6.0	
50.0	6.0	6.0	6.0	6.0	
55.0	6.0	6.0	6.0	5.8	4.9
60.0	6.0	6.0	6.0	5.6	4.8
65.0	5.9	6.0	5.8	5.4	4.7
70.0	4.4	5.4	5.6	5.1	4.7
75.0	3.2	4.0	4.7	4.8	
80.0	2.1	2.7	3.3	3.9	
85.0		1.6	2.0		
危険角度(°)	35	36	37	45	60
フック種類	12t				
フック質量(t)	0.53				
掛数	1				

● 45mブーム+4.4m+54mヘビーリフトジブ

HA性能					
オフセット	10°	20°	30°	45°	60°
作業半径(m)	荷重 (t)	荷重 (t)	荷重 (t)	荷重 (t)	荷重 (t)
24.0	5.5				
26.0	5.5				
28.0	5.5				
30.0	5.5				
32.0	5.5	5.5			
34.0	5.5	5.5			
36.0	5.5	5.5			
38.0	5.5	5.5			
40.0	5.5	5.5	5.5		
42.0	5.5	5.5	5.5		
44.0	5.5	5.5	5.5		
46.0	5.5	5.5	5.5		
48.0	5.5	5.5	5.5		
50.0	5.5	5.5	5.5	5.5	
55.0	5.5	5.5	5.5	5.3	
60.0	5.5	5.5	5.5	5.1	3.8
65.0	5.5	5.5	5.5	5.0	3.8
70.0	4.0	5.0	5.5	4.9	3.8
75.0	2.8	3.6	4.4	4.9	3.8
80.0	1.7	2.4	3.1	3.8	
85.0		1.8	2.3		
危険角度(°)	40	44	44	45	60
フック種類	12t				
フック質量(t)	0.53				
掛数	1				

KATO KA-3000R

■ 定格総荷重表

● 50mブーム+4.4m+54mヘビーリフトジブ

HA性能					
オフセット	10°	20°	30°	45°	60°
作業半径(m)	荷重 (t)	荷重 (t)	荷重 (t)	荷重 (t)	荷重 (t)
24.0	4.1				
26.0	4.1				
28.0	4.1				
30.0	4.1				
32.0	4.1	4.0			
34.0	4.1	4.0			
36.0	4.1	4.0			
38.0	4.1	4.0			
40.0	4.1	4.0	3.8		
42.0	4.1	4.0	3.7		
44.0	4.1	4.0	3.6		
46.0	4.1	4.0	3.5		
48.0	4.1	4.0	3.4		
50.0	4.1	3.9	3.3	2.3	
55.0	4.1	3.7	3.1	2.2	
60.0	4.0	3.5	2.9	2.1	
65.0	3.8	3.3	2.8	2.0	
70.0	3.2	3.2	2.7	2.0	
75.0	2.4	3.0	2.7	2.0	
80.0		2.1	2.6	2.0	
85.0			1.6	2.0	
危険角度(°)	47	47	48	50	
フック種類	12t				
フック質量(t)	0.53				
掛数	1				

● 53.9mブーム+4.4m+54mヘビーリフトジブ

HA性能					
オフセット	10°	20°	30°	45°	60°
作業半径(m)	荷重 (t)	荷重 (t)	荷重 (t)	荷重 (t)	荷重 (t)
24.0	3.5				
26.0	3.5				
28.0	3.5				
30.0	3.5				
32.0	3.5				
34.0	3.5	3.3			
36.0	3.5	3.1			
38.0	3.5	3.0			
40.0	3.5	2.9	2.2		
42.0	3.4	2.8	2.1		
44.0	3.3	2.7	2.0		
46.0	3.2	2.5	2.0		
48.0	3.0	2.5	1.9		
50.0	2.9	2.4	1.8		
55.0	2.7	2.2	1.7		
60.0	2.5	2.0	1.6		
65.0	2.3	1.9			
70.0	2.0	1.9			
75.0		1.8			
危険角度(°)	53	54	67		
フック種類	12t				
フック質量(t)	0.53				
掛数	1				

● 14.4mブーム+4.4m+54mヘビーリフトジブ

HB性能					
オフセット	10°	20°	30°	45°	60°
作業半径(m)	荷重 (t)	荷重 (t)	荷重 (t)	荷重 (t)	荷重 (t)
18.0	9.3				
20.0	9.3				
22.0	9.2				
24.0	9.2				
26.0	9.2				
28.0	9.2	8.9			
30.0	9.0	8.8			
32.0	8.8	8.7			
34.0	8.8	8.6			
36.0	8.8	8.5	7.9		
38.0	8.7	8.1	7.6		
40.0	8.3	7.8	7.3		
42.0	7.9	7.5	7.0		
44.0	7.6	7.2	6.8		
46.0	7.3	6.9	6.6	6.1	
48.0	7.0	6.7	6.4	5.9	
50.0	6.8	6.5	6.2	5.8	
55.0	6.2	6.0	5.7	5.5	5.0
60.0	5.7	5.6	5.4	5.0	4.7
65.0	5.3	5.1	4.9	4.7	
70.0	4.8				
危険角度(°)	10	20	30	45	60
フック種類	12t				
フック質量(t)	0.53				
掛数	1				

● 19.55mブーム+4.4m+54mヘビーリフトジブ

HB性能					
オフセット	10°	20°	30°	45°	60°
作業半径(m)	荷重 (t)	荷重 (t)	荷重 (t)	荷重 (t)	荷重 (t)
20.0	9.3				
22.0	9.2				
24.0	9.2				
26.0	9.2				
28.0	9.0	8.9			
30.0	9.0	8.9			
32.0	8.9	8.9			
34.0	8.9	8.8			
36.0	8.9	8.7	8.0		
38.0	8.8	8.4	7.7		
40.0	8.7	8.0	7.5		
42.0	8.3	7.7	7.2		
44.0	8.0	7.5	7.0		
46.0	7.7	7.2	6.7	6.2	
48.0	7.4	7.0	6.5	6.0	
50.0	7.2	6.7	6.3	5.8	
55.0	6.6	6.2	5.9	5.5	5.1
60.0	6.1	5.8	5.6	5.2	4.8
65.0	5.7	5.5	5.2	4.8	
70.0	5.2	5.0	4.8		
75.0	4.8				
危険角度(°)	10	20	30	45	60
フック種類	12t				
フック質量(t)	0.53				
掛数	1				

● 23.6mブーム+4.4m+54mヘビーリフトジブ

HB性能					
オフセット	10°	20°	30°	45°	60°
作業半径(m)	荷重 (t)	荷重 (t)	荷重 (t)	荷重 (t)	荷重 (t)
20.0	9.3				
22.0	9.3				
24.0	9.2				
26.0	9.2				
28.0	9.2	9.1			
30.0	9.0	8.9			
32.0	8.9	8.8			
34.0	8.9	8.7			
36.0	8.9	8.6	8.1		
38.0	8.8	8.5	7.8		
40.0	8.7	8.2	7.6		
42.0	8.6	7.9	7.3		
44.0	8.3	7.6	7.1		
46.0	8.0	7.4	6.9	6.2	
48.0	7.7	7.1	6.7	6.0	
50.0	7.4	6.9	6.5	5.9	
55.0	6.8	6.4	6.0	5.6	5.1
60.0	6.3	6.0	5.7	5.3	4.8
65.0	5.9	5.6	5.4	4.9	4.7
70.0	5.2	5.3	5.0	4.7	
75.0	4.0	4.3	4.6		
危険角度(°)	15	20	30	45	60
フック種類	12t				
フック質量(t)	0.53				
掛数	1				

● 32mブーム+4.4m+54mヘビーリフトジブ

HB性能					
オフセット	10°	20°	30°	45°	60°
作業半径(m)	荷重 (t)	荷重 (t)	荷重 (t)	荷重 (t)	荷重 (t)
22.0	9.0				
24.0	9.0				
26.0	9.0				
28.0	9.0				
30.0	9.0	8.8			
32.0	9.0	8.7			
34.0	8.9	8.7			
36.0	8.8	8.6			
38.0	8.8	8.6	8.0		
40.0	8.7	8.6	7.7		
42.0	8.6	8.3	7.5		
44.0	8.6	8.0	7.3		
46.0	8.6	7.7	7.1		
48.0	8.3	7.5	6.9	6.1	
50.0	8.0	7.3	6.7	6.0	
55.0	7.4	6.8	6.3	5.7	5.2
60.0	6.8	6.3	5.9	5.5	4.9
65.0	5.7	6.0	5.6	5.2	4.7
70.0	4.3	5.1	5.4	4.9	4.6
75.0	3.1	3.7	4.3	4.7	
80.0	2.0	2.5	2.9		
危険角度(°)	23	27	30	45	60
フック種類	12t				
フック質量(t)	0.53				
掛数	1				

KA-3000R

KATO KA-3000R

■ 定格総荷重表

● 40mブーム+4.4m+54mヘビーリフトジブ

HB性能					
オフセット	10°	20°	30°	45°	60°
作業半径(m)	荷重 (t)	荷重 (t)	荷重 (t)	荷重 (t)	荷重 (t)
22.0	6.0				
24.0	6.0				
26.0	6.0				
28.0	6.0				
30.0	6.0				
32.0	6.0	6.0			
34.0	6.0	6.0			
36.0	6.0	6.0			
38.0	6.0	6.0	6.0		
40.0	6.0	6.0	6.0		
42.0	6.0	6.0	6.0		
44.0	6.0	6.0	6.0		
46.0	6.0	6.0	6.0		
48.0	6.0	6.0	6.0	6.0	
50.0	6.0	6.0	6.0	6.0	
55.0	6.0	6.0	6.0	5.8	4.9
60.0	6.0	6.0	6.0	5.6	4.8
65.0	4.9	6.0	5.8	5.4	4.7
70.0	3.6	4.5	5.3	5.1	4.7
75.0	2.4	3.2	3.9	4.7	
80.0		2.0	2.5	3.1	
危険角度(°)	41	42	43	45	60
フック種類	12t				
フック質量(t)	0.53				
掛数	1				

● 45mブーム+4.4m+54mヘビーリフトジブ

HB性能					
オフセット	10°	20°	30°	45°	60°
作業半径(m)	荷重 (t)	荷重 (t)	荷重 (t)	荷重 (t)	荷重 (t)
24.0	5.5				
26.0	5.5				
28.0	5.5				
30.0	5.5				
32.0	5.5	5.5			
34.0	5.5	5.5			
36.0	5.5	5.5			
38.0	5.5	5.5			
40.0	5.5	5.5	5.5		
42.0	5.5	5.5	5.5		
44.0	5.5	5.5	5.5		
46.0	5.5	5.5	5.5		
48.0	5.5	5.5	5.5		
50.0	5.5	5.5	5.5	5.5	
55.0	5.5	5.5	5.5	5.3	
60.0	5.5	5.5	5.5	5.1	3.8
65.0	4.5	5.5	5.5	5.0	3.8
70.0	3.2	4.2	5.1	4.9	3.8
75.0	2.0	2.8	3.6	4.6	3.8
80.0		1.7	2.3	3.0	
85.0				1.6	
危険角度(°)	44	46	47	47	60
フック種類	12t				
フック質量(t)	0.53				
掛数	1				

● 50mブーム+4.4m+54mヘビーリフトジブ

HB性能					
オフセット	10°	20°	30°	45°	60°
作業半径(m)	荷重 (t)	荷重 (t)	荷重 (t)	荷重 (t)	荷重 (t)
24.0	4.1				
26.0	4.1				
28.0	4.1				
30.0	4.1				
32.0	4.1	4.0			
34.0	4.1	4.0			
36.0	4.1	4.0			
38.0	4.1	4.0			
40.0	4.1	4.0	3.8		
42.0	4.1	4.0	3.7		
44.0	4.1	4.0	3.6		
46.0	4.1	4.0	3.5		
48.0	4.1	4.0	3.4		
50.0	4.1	3.9	3.3	2.3	
55.0	4.1	3.7	3.1	2.2	
60.0	4.0	3.5	2.9	2.1	
65.0	3.8	3.3	2.8	2.0	
70.0	2.8	3.2	2.7	2.0	
75.0	1.6	2.5	2.7	2.0	
80.0			2.1	2.0	
危険角度(°)	49	52	52	54	
フック種類	12t				
フック質量(t)	0.53				
掛数	1				

● 53.9mブーム+4.4m+54mヘビーリフトジブ

HB性能					
オフセット	10°	20°	30°	45°	60°
作業半径(m)	荷重 (t)	荷重 (t)	荷重 (t)	荷重 (t)	荷重 (t)
24.0	3.5				
26.0	3.5				
28.0	3.5				
30.0	3.5				
32.0	3.5				
34.0	3.5	3.3			
36.0	3.5	3.1			
38.0	3.5	3.0			
40.0	3.5	2.9	2.2		
42.0	3.4	2.8	2.1		
44.0	3.3	2.7	2.0		
46.0	3.2	2.5	2.0		
48.0	3.0	2.5	1.9		
50.0	2.9	2.4	1.8		
55.0	2.7	2.2	1.7		
60.0	2.5	2.0	1.6		
65.0	2.3	1.9			
70.0	2.0	1.9			
75.0		1.8			
危険角度(°)	53	54	67		
フック種類	12t				
フック質量(t)	0.53				
掛数	1				

● 14.4mブーム+4.4m+54mヘビーリフトジブ

HC性能					
オフセット	10°	20°	30°	45°	60°
作業半径(m)	荷重 (t)	荷重 (t)	荷重 (t)	荷重 (t)	荷重 (t)
18.0	9.3				
20.0	9.3				
22.0	9.2				
24.0	9.2				
26.0	9.2				
28.0	9.2	8.9			
30.0	9.0	8.8			
32.0	8.8	8.7			
34.0	8.8	8.6			
36.0	8.8	8.5	7.9		
38.0	8.7	8.1	7.6		
40.0	8.3	7.8	7.3		
42.0	7.9	7.5	7.0		
44.0	7.6	7.2	6.8		
46.0	7.3	6.9	6.6	6.1	
48.0	7.0	6.7	6.4	5.9	
50.0	6.8	6.5	6.2	5.8	
55.0	6.2	6.0	5.7	5.5	5.0
60.0	5.7	5.6	5.4	5.0	4.7
65.0	5.3	5.1	4.9	4.7	
70.0	4.8				
危険角度(°)	10	20	30	45	60
フック種類	12t				
フック質量(t)	0.53				
掛数	1				

● 19.55mブーム+4.4m+54mヘビーリフトジブ

HC性能					
オフセット	10°	20°	30°	45°	60°
作業半径(m)	荷重 (t)	荷重 (t)	荷重 (t)	荷重 (t)	荷重 (t)
20.0	9.3				
22.0	9.2				
24.0	9.2				
26.0	9.2				
28.0	9.0	8.9			
30.0	9.0	8.9			
32.0	8.9	8.9			
34.0	8.9	8.8			
36.0	8.9	8.7	8.0		
38.0	8.8	8.4	7.7		
40.0	8.7	8.0	7.5		
42.0	8.3	7.7	7.2		
44.0	8.0	7.5	7.0		
46.0	7.7	7.2	6.7	6.2	
48.0	7.4	7.0	6.5	6.0	
50.0	7.2	6.7	6.3	5.8	
55.0	6.6	6.2	5.9	5.5	5.1
60.0	6.1	5.8	5.6	5.2	4.8
65.0	5.7	5.5	5.2	4.8	
70.0	5.2	5.0	4.8		
75.0	4.2				
危険角度(°)	10	20	30	45	60
フック種類	12t				
フック質量(t)	0.53				
掛数	1				

KATO KA-3000R

■ 定格総荷重表

● 23.6mブーム+4.4m+54mヘビーリフトジブ

HC性能					
オフセット	10°	20°	30°	45°	60°
作業半径(m)	荷重 (t)	荷重 (t)	荷重 (t)	荷重 (t)	荷重 (t)
20.0	9.3				
22.0	9.3				
24.0	9.2				
26.0	9.2				
28.0	9.2	9.1			
30.0	9.0	8.9			
32.0	8.9	8.8			
34.0	8.9	8.7			
36.0	8.9	8.6	8.1		
38.0	8.8	8.5	7.8		
40.0	8.7	8.2	7.6		
42.0	8.6	7.9	7.3		
44.0	8.3	7.6	7.1		
46.0	8.0	7.4	6.9	6.2	
48.0	7.7	7.1	6.7	6.0	
50.0	7.4	6.9	6.5	5.9	
55.0	6.8	6.4	6.0	5.6	5.1
60.0	6.3	6.0	5.7	5.3	4.8
65.0	5.6	5.6	5.4	4.9	4.7
70.0	4.3	4.9	5.0	4.7	
75.0	3.2	3.5	3.8		
危険角度(°)	15	20	30	45	60
フック種類	12t				
フック質量(t)	0.53				
掛数	1				

● 32mブーム+4.4m+54mヘビーリフトジブ

HC性能					
オフセット	10°	20°	30°	45°	60°
作業半径(m)	荷重 (t)	荷重 (t)	荷重 (t)	荷重 (t)	荷重 (t)
22.0	9.0				
24.0	9.0				
26.0	9.0				
28.0	9.0				
30.0	9.0	8.8			
32.0	9.0	8.7			
34.0	8.9	8.7			
36.0	8.8	8.6			
38.0	8.8	8.6	8.0		
40.0	8.7	8.6	7.7		
42.0	8.6	8.3	7.5		
44.0	8.6	8.0	7.3		
46.0	8.6	7.7	7.1		
48.0	8.3	7.5	6.9	6.1	
50.0	8.0	7.3	6.7	6.0	
55.0	7.4	6.8	6.3	5.7	5.2
60.0	6.3	6.3	5.9	5.5	4.9
65.0	4.7	5.6	5.6	5.2	4.7
70.0	3.4	4.2	4.9	4.9	4.6
75.0	2.3	2.9	3.5	4.1	
80.0		1.7	2.1		
危険角度(°)	33	33	35	45	60
フック種類	12t				
フック質量(t)	0.53				
掛数	1				

● 40mブーム+4.4m+54mヘビーリフトジブ

HC性能					
オフセット	10°	20°	30°	45°	60°
作業半径(m)	荷重 (t)	荷重 (t)	荷重 (t)	荷重 (t)	荷重 (t)
22.0	6.0				
24.0	6.0				
26.0	6.0				
28.0	6.0				
30.0	6.0				
32.0	6.0	6.0			
34.0	6.0	6.0			
36.0	6.0	6.0			
38.0	6.0	6.0	6.0		
40.0	6.0	6.0	6.0		
42.0	6.0	6.0	6.0		
44.0	6.0	6.0	6.0		
46.0	6.0	6.0	6.0		
48.0	6.0	6.0	6.0	6.0	
50.0	6.0	6.0	6.0	6.0	
55.0	6.0	6.0	6.0	5.8	4.9
60.0	5.5	6.0	6.0	5.6	4.8
65.0	4.0	5.1	5.8	5.4	4.7
70.0	2.7	3.6	4.5	5.1	4.7
75.0	1.6	2.3	3.1	3.9	
80.0			1.8	2.4	
危険角度(°)	43	45	45	46	60
フック種類	12t				
フック質量(t)	0.53				
掛数	1				

● 45mブーム+4.4m+54mヘビーリフトジブ

HC性能					
オフセット	10°	20°	30°	45°	60°
作業半径(m)	荷重 (t)	荷重 (t)	荷重 (t)	荷重 (t)	荷重 (t)
24.0	5.5				
26.0	5.5				
28.0	5.5				
30.0	5.5				
32.0	5.5	5.5			
34.0	5.5	5.5			
36.0	5.5	5.5			
38.0	5.5	5.5			
40.0	5.5	5.5	5.5		
42.0	5.5	5.5	5.5		
44.0	5.5	5.5	5.5		
46.0	5.5	5.5	5.5		
48.0	5.5	5.5	5.5		
50.0	5.5	5.5	5.5	5.5	
55.0	5.5	5.5	5.5	5.3	
60.0	5.1	5.5	5.5	5.1	3.8
65.0	3.6	4.7	5.5	5.0	3.8
70.0	2.3	3.3	4.2	4.9	3.8
75.0		2.0	2.8	3.8	3.8
80.0				2.3	
危険角度(°)	49	49	52	52	60
フック種類	12t				
フック質量(t)	0.53				
掛数	1				

● 50mブーム+4.4m+54mヘビーリフトジブ

HC性能					
オフセット	10°	20°	30°	45°	60°
作業半径(m)	荷重 (t)	荷重 (t)	荷重 (t)	荷重 (t)	荷重 (t)
24.0	4.1				
26.0	4.1				
28.0	4.1				
30.0	4.1				
32.0	4.1	4.0			
34.0	4.1	4.0			
36.0	4.1	4.0			
38.0	4.1	4.0			
40.0	4.1	4.0	3.8		
42.0	4.1	4.0	3.7		
44.0	4.1	4.0	3.6		
46.0	4.1	4.0	3.5		
48.0	4.1	4.0	3.4		
50.0	4.1	3.9	3.3	2.3	
55.0	4.1	3.7	3.1	2.2	
60.0	4.0	3.5	2.9	2.1	
65.0	3.2	3.3	2.8	2.0	
70.0	1.9	3.0	2.7	2.0	
75.0		1.7	2.6	2.0	
80.0				2.0	
危険角度(°)	51	53	55	55	
フック種類	12t				
フック質量(t)	0.53				
掛数	1				

● 53.9mブーム+4.4m+54mヘビーリフトジブ

HC性能					
オフセット	10°	20°	30°	45°	60°
作業半径(m)	荷重 (t)	荷重 (t)	荷重 (t)	荷重 (t)	荷重 (t)
24.0	3.5				
26.0	3.5				
28.0	3.5				
30.0	3.5				
32.0	3.5				
34.0	3.5	3.3			
36.0	3.5	3.1			
38.0	3.5	3.0			
40.0	3.5	2.9	2.2		
42.0	3.4	2.8	2.1		
44.0	3.3	2.7	2.0		
46.0	3.2	2.5	2.0		
48.0	3.0	2.5	1.9		
50.0	2.9	2.4	1.8		
55.0	2.7	2.2	1.7		
60.0	2.5	2.0	1.6		
65.0	2.3	1.9			
70.0	1.7	1.9			
危険角度(°)	54	57	67		
フック種類	12t				
フック質量(t)	0.53				
掛数	1				

KA-3000R

KATO KA-3000R

KA-3000R

■ 定格総荷重表注意事項

1. 定格総荷重表は水平堅土上において機体を水平に設置した状態での保証できる最大荷重を示しており、フックその他つり具等の質量を含んだ値です。なお、太枠の内側は機械の強度によって定められ、下側は機械の安定度によって定められています。
2. 定格総荷重は、アウトリガー・サイドサポート・ブームロックを使用した状態で、アウトリガーの張出幅とカウンターウエイトの装備状態により、下表のように区分されます。
3. 各ブーム条件において吊方向が前方・後方時は、側方性能がある場合アウトリガ張出幅最大の状態と同じ性能になります。

ブーム<重荷重> 【全周・後方】

吊方向	カウンターウエイト	A
アウトリガー張出幅		105t
全周*	8.4m	AA

*最大荷重は後方のみ

ブーム<通常伸縮>

吊方向	カウンターウエイト	A	B	C	D	E	F	G	H	J	K
アウトリガー張出幅		105t	93t	81t	69t	51t	41t	31t	21t	11t	0t
側方	9.4m	A1	B1	C1	D1	E1	F1	G1	H1	J1	K1
	8.4m	A2	B2	C2	D2	E2	F2	G2	H2	J2	K2
	7.4m				D3	E3	F3	G3	H3	J3	K3
	6.4m						F4	G4	H4	J4	K4
	5.4m								H5	J5	K5

ブーム<特殊伸縮>

吊方向	カウンターウエイト	A	B	C	D	E	F	G	H	J	K
アウトリガー張出幅		105t	93t	81t	69t	51t	41t	31t	21t	11t	0t
側方	9.4m	TA1	TB1	TC1	TD1	TE1	TF1	TG1	TH1	TJ1	TK1
	8.4m	TA2	TB2	TC2	TD2	TE2	TF2	TG2	TH2	TJ2	TK2
	7.4m				TD3	TE3	TF3	TG3	TH3	TJ3	TK3
	6.4m						TF4	TG4	TH4	TJ4	TK4
	5.4m								TH5	TJ5	TK5

特殊伸縮：2段ブームを伸ばさずに、3、4、5段ブームを等長で伸縮させる伸縮方式です。

SLジブ

吊方向	カウンターウエイト	A	B	C	D	E	F	G	H	J	K
アウトリガー張出幅		105t	93t	81t	69t	51t	41t	31t	21t	11t	0t
側方	9.4m	SA	SB	SC	SD	SE	SF	SG	SH	SJ	SK
	8.4m					SF	SG	SH	SJ	SK	
	7.4m				SE	SG	SH				

ヘビーリフトジブ

吊方向	カウンターウエイト	A	B	C	D	E	F	G
アウトリガー張出幅		105t	93t	81t	69t	51t	41t	31t
側方	9.4m	HA	HB	HC	HD	HE	HF	HG
	8.4m				HE	HF	HG	
	7.4m				HF			

4. 前方領域及び後方領域の範囲を下記に示します。

作業状態	重荷重	通常
領域α	-	15°
領域β	5°	15°

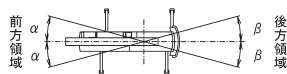

5. 定格総荷重のブーム角度は、ブームと水平面のなす角度を示し、ジブ角度はブームとジブのなす角度を示します。
6. 作業半径は、ブームおよびジブのたわみを含んだ実際値に基づいていますので必ず作業半径を基準として作業を行ってください。
7. SLジブの作業半径は、40、45、50または55mブームにSLジブを装着してクレーン作業を行う場合の値です。40m未満のブーム長さでSLジブ作業を行う場合は、作業半径ではなく40mブームのブーム角度を基準としてください。
8. ブーム長さ、ブーム角度、作業半径、ジブ長さおよび角度が規定の値をこえる場合は、その規定の値と次の規定の値の定格総荷重のうち、小さい方の定格総荷重を目安として作業を行ってください。

9. 各々の作業状態におけるブーム危険角度は表の通りです。ブームを危険角度以下にしますと無負荷でも転倒しますので充分注意してください。
10. SLジブを装着したままでブーム作業（通常伸縮）を行う場合の定格総荷重は、ブームの定格総荷重よりフックその他つり具等の質量の他にSLジブ長さに応じて下表の荷重を差し引いてください。また、アウトリガーの張出幅とカウンターウエイトの装備状態はSLジブの性能区分を参考にしてください。なお、SLジブを装着したままのブーム作業は、ブーム状態が通常伸縮時に限ります。

SLジブ長さ	10.85m	15m	20m	25m	30m	35m
差引荷重	19t			29t		

11. ルースターシーブの定格総荷重は、ブームの定格総荷重よりブームに取付けられているフック、その他の吊り具等の質量を差し引いた値とし、かつ上限を12tとします。
12. 総荷重が150tを超える場合は重荷重装置を使用してください。
13. ヘビーリフトジブ31mの単索時定格総荷重は、ヘビーリフトジブ31mの定格総荷重と等しく、かつ上限を12tとします。
14. ヘビーリフトジブの起伏用ロープは、6本掛にしてください。
15. 作業状態別標準フックの種類・掛数・質量を次に示します。なお、下表12tフック使用にあたり、ヘビーリフトジブ作業時にはサブウエイト有（530kg）、ブーム作業（ルースターシーブ）・SLジブ作業時にはサブウエイト無（420kg）のフックを使用してください。

フック種類	300t	150t	83t	24t	12t
フック質量	3800kg	1900kg	1000kg	880kg	サブウエイト無/有
					420kg 530kg

ブーム【通常伸縮】

ブーム長さ	14.4m	19.55m	23.6m	24.7m	32m	40m	45m	50m	55m
フック種類	300t	150t	150t	150t	150t	83t	83t	83t	83t
掛数	14×2	14	12	12	12	7	6	4	4

ブーム<特殊伸縮>

ブーム長さ	14.4m	19.55m	24.7m	32m	40m	44.7m
フック種類	150t	83t	83t	83t	83t	83t
掛数	14	7	7	6	4	4

ルースターシーブ

フック種類	12t
掛数	1

SLジブ

SLジブ長さ	10.85m	15m	20m	25m	30m	35m
フック種類	24t	12t	12t	12t	12t	12t
掛数	1	1	1	1	1	1

ヘビーリフトジブ

ブーム長さ	HL長さ	13m	22m	31m	40m	47m	54m
14.4m	フック種類	150t	83t	83t (12t)	12t	12t	12t
	掛数	8	6	4 (1)	1	1	1
19.55m	フック種類	150t	83t	83t (12t)	12t	12t	12t
	掛数	8	6	4 (1)	1	1	1
23.6m	フック種類	83t	83t	83t (12t)	12t	12t	12t
	掛数	6	4	4 (1)	1	1	1
32m	フック種類	83t	83t	24t (12t)	12t	12t	12t
	掛数	4	4	2 (1)	1	1	1
40m	フック種類	-	24t	24t (12t)	12t	12t	12t
	掛数	-	2	2 (1)	1	1	1
45m	フック種類	-	24t	24t (12t)	12t	12t	12t
	掛数	-	2	2 (1)	1	1	1
50m	フック種類	-	24t	24t (12t)	12t	12t	12t
	掛数	-	2	2 (1)	1	1	1
53.9m	フック種類	-	24t	24t (12t)	12t	12t	12t
	掛数	-	2	2 (1)	1	1	1

16. クレーン作業は風速10m/sまで可能ですが、比較的弱い風の場合でも受風面積の大きい荷重を取扱う場合は特別な注意を払ってください
17. 定格総荷重をこえる作業を行った場合、および正しい使い方を行わなかった場合は転倒または破損します。この場合本機の保証はいたしません。
18. 本仕様は改良等により予告なく変更する事があります。